

**INFORMAZIONI GENERALI**

Il presente catalogo serve per richiedere con esattezza le parti di ricambio  
Nelle ordinazioni indicare:

- 1) il numero di codice dei particolari seguito dalla descrizione;
  - 2) il colore per i pezzi verniciati o comunque colorati;
  - 3) il numero di matricola del motociclo, stampigliato sul canotto di sterzo.
- Le indicazioni destra e sinistra si riferiscono ai lati del veicolo rispetto al senso di marcia.

**GENERAL INFORMATION**

The present spare parts list enables one to order exactly the right spare parts.  
When ordering specify:

- 1) the part's code number followed by its description;
  - 2) indicate colour for painted or coloured parts;
  - 3) the motorcycle's serial number, stamped on the steering head.
- References to right and left apply to the vehicle in terms of its direction of movement.

**INFORMATIONS GENERALES**

Ca catalogue permet de commander correctement les pièces de rechange.  
Les commandes doivent être passées en indiquant:

- 1) le numéro de code des pièces détachées suivi de leur description;
  - 2) le couleur des pièces peintes ou colorées;
  - 3) le matricule de la moto, estampillé sur la tige du guidon.
- Droite et gauche sont les côtés du véhicule par rapport au sens de la marche.

**ALLGEMEINE HINWEISE**

Dieser Ersatzteilkatalog dient zur genauen Angabe der Teile bei Ersatzteilbestellungen.  
Bei Ersatzbestellung ist folgendes anzugeben:

- 1) Die Bestellnummer der Ersatzteile mit der entsprechenden Beschreibung;
  - 2) Farbe für lackierte und farbige Teile angeben;
  - 3) Die Sseriennummer des Motorrads, die am Lenkrohr eingepreßt ist.
- Die Angaben rechts und links beziehen sich auf das Fahrzeug in Fahrrichtung.

**INFORMACIONES GENERALES**

El presente catálogo sirve para pedir con exactitud las partes de recambio.  
En los pedidos se debe indicar:

- 1) el número de código de la parte y a continuación la descripción;
  - 2) el color para las piezas barnizadas o coloreadas;
  - 3) el número de matrícula de la motocicleta, estampado en el tubo de dirección.
- Las indicaciones derecha e izquierda se refieren a los lados del vehículo respecto del sentido de marcha.

**NOTE - LIST - NOTES - NOTE - NOTAS:**

- A** : In alternativa - In alternative - En alternative  
Wahlweise - En alternativa
- C** : Modello **TC** - **TC** model - Modèle **TC** - Modell **TC** - Modélo **TC**
- D** : In dotazione - To issue - En necessaire  
Ausstattungsteile - En dotación
- E** : Ad esaurimento - To fell out - A' finir - Erschöpfung - A agotamiento

- F** : Fornire assieme - Supply unitedly - Fournir ensemble  
Wird zusammen geliefert - Equipar juntos
- M** : Modello **SMR** - **SMR** model - Modèle **SMR** - Modell **SMR** - Modélo **SMR**
- N** : Non fornito - Not supplied - Ne pas fournir  
Keine Lieferende - No equiparado
- Ø** : Non per JPN - Not for JPN - Ne pas pour JPN  
Keine für JPN - No por JPN
- P** : Non per SMR - Not for SMR - Ne pas pour SMR  
Keine für SMR - No por SMR
- Q** : Solo per SMR / U.S.A. - Only for SMR / U.S.A. -  
Soulement pour SMR / U.S.A.  
Nur für SMR / U.S.A. - Solo por SMR / U.S.A.
- R** : A richiesta - Upon request - Sur demande - Auf anfrage - Bajo pedido
- S** : Di serie - Supplied - De série - Standard - De serie
- U** : Solo per TE/ U.S.A. - Only for TE/ U.S.A. -  
Soulement pour TE/ U.S.A.  
Nur für TE/ U.S.A. - Solo por TE/ U.S.A.
- X** : Non per U.S.A. - Not for U.S.A. - Ne pas pour U.S.A.  
Keine für U.S.A. - No por U.S.A.
- XB** : Non per BR - Not for BR - Ne pas pour BR  
Keine für BR - No por BR
- Y** : Non per TC - Not for TC - Ne pas pour TC - Keine für TC - No por TC
- ¥** : Solo per SMR 400 - Only for SMR 400 - Soulement pour SMR 400  
Nur für SMR 400 - Solo por SMR 400
- W** : Modello **TE** - **TE** model - Modèle **TE** - Modell **TE** - Modélo **TE**
- Z** : n° denti, number of teeth, numéro dents, Zähne nummer  
número dientes

- A** : Austria, Austria, Autriche, Österreich, Austria
- AUS** : Australia, Australia, Australie, Australien, Australia
- B** : Belgio, Belgium, Belgique, Belgien, Bélgica
- BR** : Brasile, Brazil, Brasile, Brasilien, Brasil
- CDN** : Canada, Canada, Canada, Kanada, Canadá
- CH** : Svizzera, Switzerland, Suisse, Schweizer, Suiza
- D** : Germania, Germany, Allemagne, Deutschland, Alemania
- E** : Spagna, Spain, Espagne, Spanien, España
- F** : Francia, France, France, Frankreich, Francia
- GB** : Gran Bretagna, Great Britain, Grand Bretagne  
Groos Britan, Gran Bretaña
- I** : Italia, Italy, Italie, Italien, Italia
- J** : Giappone, Japan, Japon, Japan, Japón
- SF** : Finlandia, Finald, Finlande, Finnland, Finlandia
- USA** : Stati Uniti d'America, United States of America, Etats Units d'Amerique,  
Vereinigte Staaten von Amerika, Estados Unidos

Dati indicativi soggetti a modifiche senza impegno di preavviso.  
All data are subject to modification without prior notice.  
Données indicatif sujet au modifications sans obligation de préavis.  
Anderungen Vorbehalten.  
Datos indicativos sujetos a modificaciones sin compromiso de preaviso.

- Il n° di matricola iniziale del modello **TC 250/2004** è **ZCGH800AA4V050001**  
Il n° di matricola iniziale del modello **TC 450/2004** è **ZCGH802BA4V050001**  
Il n° di matricola iniziale del modello **TE 250/2004** è **ZCGH800AC4V000001**  
Il n° di matricola iniziale del modello **TE 250/2004 USA** è **ZCGTE250#4V000001**  
Il n° di matricola iniziale del modello **TE 450/2004** è **ZCGH802BC4V000001**  
Il n° di matricola iniziale del modello **TE 450/2004 USA** è **ZCGTE450#4V000001**  
Il n° di matricola iniziale del modello **SM 400R/2004** è **ZCGH801AD4V000001**  
Il n° di matricola iniziale del modello **SM 450R/2004** è **ZCGH802BD4V000001**  
Il n° di matricola iniziale del modello **SM 450R/2004 USA** è **ZCGSM450#4V000001**

The initial serial number for the **TC 250/2004** model is **ZCGH800AA4V050001**  
The initial serial number for the **TC 450/2004** model is **ZCGH802BA4V050001**  
The initial serial number for the **TE 250/2004** model is **ZCGH800AC4V000001**  
The initial serial number for the **TE 250/2004 USA** model is **ZCGTE250#4V000001**  
The initial serial number for the **TE 450/2004** model is **ZCGH802BC4V000001**  
The initial serial number for the **TE 450/2004 USA** model is **ZCGTE450#4V000001**  
The initial serial number for the **SM 400R/2004** model is **ZCGH801AD4V000001**  
The initial serial number for the **SM 450R/2004** model is **ZCGH802BD4V000001**  
The initial serial number for the **SM 450R/2004 USA** model is **ZCGSM450#4V000001**

Le matricule initial du modèle **TC 250/2004** est **ZCGH800AA4V050001**  
Le matricule initial du modèle **TC 450/2004** est **ZCGH802BA4V050001**  
Le matricule initial du modèle **TE 250/2004** est **ZCGH800AC4V000001**  
Le matricule initial du modèle **TE 250/2004 USA** est **ZCGTE250#4V000001**  
Le matricule initial du modèle **TE 450/2004** est **ZCGH802BC4V000001**  
Le matricule initial du modèle **TE 450/2004 USA** est **ZCGTE450#4V000001**  
Le matricule initial du modèle **SM 400R/2004** est **ZCGH801AD4V000001**  
Le matricule initial du modèle **SM 450R/2004** est **ZCGH802BD4V000001**  
Le matricule initial du modèle **SM 450R/2004 USA** est **ZCGSM450#4V000001**

Die Seriennummer des Modells **TC 250/2004** beginnt mit **ZCGH800AA4V050001**  
Die Seriennummer des Modells **TC 450/2004** beginnt mit **ZCGH802BA4V050001**  
Die Seriennummer des Modells **TE 250/2004** beginnt mit **ZCGH800AC4V000001**  
Die Seriennummer des Modells **TE 250/2004 USA** beginnt mit **ZCGTE250#4V000001**  
Die Seriennummer des Modells **TE 450/2004** beginnt mit **ZCGH802BC4V000001**  
Die Seriennummer des Modells **TE 450/2004 USA** beginnt mit **ZCGTE450#4V000001**  
Die Seriennummer des Modells **SM 400R/2004** beginnt mit **ZCGH801AD4V000001**  
Die Seriennummer des Modells **SM 450R/2004** beginnt mit **ZCGH802BD4V000001**  
Die Seriennummer des Modells **SM 450R/2004 USA** beginnt mit **ZCGSM450#4V000001**

El n° de matrícula inicial de la motocicleta **TC 250/2004** es **ZCGH800AA4V050001**  
El n° de matrícula inicial de la motocicleta **TC 450/2004** es **ZCGH802BA4V050001**  
El n° de matrícula inicial de la motocicleta **TE 250/2004** es **ZCGH800AC4V000001**  
El n° de matrícula inicial de la motocicleta **TE 250/2004 USA** es **ZCGTE250#4V000001**  
El n° de matrícula inicial de la motocicleta **TE 450/2004** es **ZCGH802BC4V000001**  
El n° de matrícula inicial de la motocicleta **TE 450/2004 USA** es **ZCGTE450#4V000001**  
El n° de matrícula inicial de la motocicleta **SM 400R/2004** es **ZCGH801AD4V000001**  
El n° de matrícula inicial de la motocicleta **SM 450R/2004** es **ZCGH802BD4V000001**  
El n° de matrícula inicial de la motocicleta **SM 450R/2004 USA** es **ZCGSM450#4V000001**

Tavola Drawing Table Bild Tabla	Denominazione	Description	Designation	Bezeichnung	Denominacion	Pagina Page Page Seite Paja
1	ATTREZZI DI ASSISTENZA, MANUALI E CATALOGHI	SERVICE TOOLS, MANUALS AND CATALOGS	OUTILS D'ASSISTANCE, MANUELS ET CATALOGUES	HILFAUSRÜSTUNG, HANDBUCH UND KATALOG	HERRAMIENTAS DE ASISTENCIA, MANUALES Y CATALOGOS	13
2	KIT IN DOTAZIONE	EQUIPMENT KITS	KIT EN NECESSAIRE	AUSRÜDTUNGSTEILEKIT	KIT EN DOTACION	15
3	CILINDRO, PISTONE	CYLINDER, PISTON	CYLINDRE, PISTON	ZYLINDER, KOLBEN	CILINDRO, PISTON	19
4	TESTA CILINDRO	CYLINDER HEAD	CULASSE	ZYLINDERKOPF	CULATA	23
5	MANOVELLISMO	CRANKSHAFT	VILEBREQUIN	KURBELWELLE	CIGÜEÑAL	29
6	TRASMISSIONE PRIMARIA, FRIZIONE	PRIMARY DRIVE, CLUTCH	TRANSMISSION PRIMAIRE, EMBAYAGE	PRIMÄRÜBERSETZUNG, KUPPLUNG	TRANSMISION PRIMARIA, EMBRAGUE	31
7	DISTRIBUZIONE	VALVE TIMING	DISTRIBUTION	VENTILSTEUERUNG	DISTRIBUCION	33
8	SEMICARTER SINISTRO	L.H. HALF CRANKCASE	CARTER G.	GEHAUSEDECKELL.	BANCADA IZQ.	37
9	SEMICARTER DESTRO	R.H. HALF CRANKCASE	CARTER D.	GEHAUSEDECKEL R.	BANCADA DER.	41
10	COPERCHIE SEMICARTER DX	R.H. HALF CRANKCASE COVERS	COUVERCLE SCARTER D.	GEHAUSEDECKEL R.	TAPAS BANCADA DER.	43
11	COPERCHIE SEMICARTER SX	L.H. HALF CRANKCASE COVERS	COUVERCLE SCARTER G.	GEHAUSEDECKELL.	TAPAS BANCADA IZQ.	45
12	LUBRIFICAZIONE	OIL PUMP	PUMPEHUILE	MOTORSCHMIERUNG	LUBRICACION	47
13	CARBURATORE	CARBURETOR	CARBURATEUR	VERGASER	CARBURADOR	51
14	PARTEELETTRICA	IGNITION SYSTEM	PARTIE ELECTRIQUE	ELEKTRISCHE TEILE	PARTE ELECTRICA	57
15	AVVIAMENTO	STARTING	DEMARRAGE	ANLASSER	ARRANQUE	59
16	CAMBIO, COMANDO CAMBIO (TC)	TRANSMISSION, SHIFTER (TC)	BOITE DE VITESSE, COMMANDE DE VITESSE (TC)	WECHSELGETRIEBE, GANGSCHALTUNG (TC)	CAMBIO, MANDO CAMBIO (TC)	63
16A	CAMBIO, COMANDO CAMBIO (TE-SMR)	TRANSMISSION, SHIFTER (TE-SMR)	BOITE DE VITESSE, COMMANDE DE VITESSE (TE-SMR)	WECHSELGETRIEBE, GANGSCHALTUNG (TE-SMR)	CAMBIO, MANDO CAMBIO (TE-SMR)	71
17	RAFFREDDAMENTO	COOLING SYSTEM	REFROIDISSEMENT	WASSERKÜHLUNG	ENFRIAMIENTO	77
18	FILTRO ARIA	AIR FILTER	FILTRE AIRE	LUFTFILTER	FILTRO DE AIRE	81
19	TELAIO, PEDANE	FRAME, FOOT RESTS	CADRE, REPOSE PIEDS	RAHMEN, FUSSBRETT	BASTIDOR, REPOSAPIES	83
20	SOSPENSIONE ANTERIORE	FRONT FORK ASSEMBLY	SUSPENSION AVANT	VORDERTELESKOPGABEL	SUSPENSION DELANTERA	87
21	FORCELLONE POSTERIORE	REAR SWING ARM	FOURCHE ARRIÈRE	HINTERGABEL	HORQUILLA TRASERA	95
22	AMMORTIZZATORE POSTERIORE	REAR SHOCK ABSORBER	AMMORTISSEUR ARRIÈRE	HINTERSTOSSDAMPFER	AMORTIGUADOR TRASERO	99
23	LEVERAGGI SOSPENSIONE POSTERIORE	REAR SUSPENSION LINKAGE	LEVIER SUSPENSION ARRIERE	HEBELWERK HINTERHAUFHANGUNG	PALANCA SUSPENSION TRASERA	103
24	MANUBRIO E COMANDI	HANDLEBAR AND CONTROLS	GUIDON ET COMMANDES	LENKER UND STEUERORGANE	MANILLAR Y MANDOS	105
25	FRENO IDRAULICO POSTERIORE	REAR HYDRAULIC BRAKE	FREIN HYDRAULIQUE ARRIERE	HINTERBREMSE	FRENO HIDRAULICO TRASERO	109
26	PANNELLI LATERALI PARAFANGHI, SELLA	SIDE PANELS, FENDERS, SEAT	PANNEAU, GARDE-BOUES, SIEGE	STREIFEN, KOTFLUGEL, SATTEL	PANELES, GUARDABARROS, SILLIN	113

Tavola Drawing Table Bild Tabla	Denominazione	Description	Designation	Bezeichnung	Denominacion	Pagina Page Page Seite Paja
27	SERBATOIOCARBURANTE, CONVOGLIATORI	GAS TANK, PANELS	RESERVOIRCARBURANT, FLANCS	KRAFTSTOFFBEHALTER, FLANKE	DEPOSITOGASOLINA, LATERALES	117
28	SCARICO	EXHAUSTSYSTEM	TUYAUD'ECHAPPEMENT	AUSPUFFROHR	TUBODEESCAPE	121
29	FRENOIDRAULICOANT. <b>(TE, TC)</b>	FRONTHYDRAULICBRAKE <b>(TE, TC)</b>	FREINHYDRAULIQUEAV. <b>(TE, TC)</b>	VORTERBREMSE <b>(TE, TC)</b>	FRENOHIDRAULICODEL.. <b>(TE, TC)</b>	125
29A	FRENOIDRAULICOANT. <b>(SMR)</b>	FRONTHYDRAULICBRAKE <b>(SMR)</b>	FREINHYDRAULIQUEAV. <b>(SMR)</b>	VORTERBREMSE <b>(SMR)</b>	FRENOHIDRAULICODEL.. <b>(SMR)</b>	127
30	RUOTAANTERIORE <b>(TE, TC)</b>	FRONTWHEEL <b>(TE, TC)</b>	ROUE AVANT <b>(TE, TC)</b>	VORTERRAD <b>(TE, TC)</b>	RUEDADELANTERA <b>(TE, TC)</b>	129
30A	RUOTAANTERIORE <b>(SMR)</b>	FRONTWHEEL <b>(SMR)</b>	ROUE AVANT <b>(SMR)</b>	VORTERRAD <b>(SMR)</b>	RUEDADELANTERA <b>(SMR)</b>	131
31	RUOTAPOSTERIORE	REARWHELL	ROUEARRIERE	HINTERRAD	RUEDA TRASERA	133
32	STRUMENTODIGITALE <b>(TE-SMR)</b>	DIGITALINSTRUMENT <b>(TE-SMR)</b>	INSTRUMENTDIGITAL <b>(TE-SMR)</b>	DIGITALTACHOMETER <b>(TE-SMR)</b>	INSTRUMENTODIGITAL <b>(TE-SMR)</b>	137
33	GRUPPOCAVI, PARTIELETTRICHE <b>(TC, TE-USA)</b>	MAINWIRINGHARNES, ELECTRICAL PARTS <b>(TC, TE-USA)</b>	CABLESPRINCIPAL, PARTIES ELECTRIQUES <b>(TC, TE-USA)</b>	KABEL, ELEKTRISCHE KOMPONENTE <b>(TC, TE-USA)</b>	GRUPOPRINCIPALCABLES, PARTES ELECTRICAS <b>(TC, TE-USA)</b>	139
33A	GRUPPOCAVI, PARTIELETTRICHE <b>(TE-SMR)</b>	MAINWIRINGHARNES, ELECTRICAL PARTS <b>(TE-SMR)</b>	CABLESPRINCIPAL, PARTIESELECTRIQUES <b>(TE-SMR)</b>	KABEL, ELEKTRISCHE KOMPONENTE <b>(TE-SMR)</b>	GRUPOPRINCIPALCABLES, PARTESELECTRICAS <b>(TE-SMR)</b>	141
33B	FANALI, PORTATARGA, PORTA- FAROANTERIORE <b>(TE-SMR)</b>	LIGHTS, PLATEHOLDER, HEADLAMPFAIRING <b>(TE-SMR)</b>	FEU, PORTE-BALAI, DOMEPORTEPHARE <b>(TE-SMR)</b>	LAMPEN, SCHILDTRAEGER, HUBE SCHEINWI-HALTER <b>(TE-SMR)</b>	FANALES, PORTA-MATRICULA CASQUETEPORTAFARO <b>(TE-SMR)</b>	143
34	INDICATORIDIDIREZIONE, AVVISATORE ACUSTICO <b>(TE-SMR)</b>	BLINKERS, HORN <b>(TE-SMR)</b>	CLIGNOTANTS, SIGNAL ACOUSTIQUE <b>(TE-SMR)</b>	BLINKERS, HUPE <b>(TE-SMR)</b>	INTERMITENTES, AVISADOR ACUSTICO <b>(TE-SMR)</b>	145
35	KITTRASFORMAZIONEENDURO <b>(TE U.S.A.)</b>	ENDUROTRANSFORMATIONKIT <b>(TE U.S.A.)</b>	SETTRANSFORMATIONENDURO <b>(TE U.S.A.)</b>	KITTRANSFORMATIONENDURO <b>(TE U.S.A.)</b>	KITTRANSFORMATIONENDURO <b>(TE U.S.A.)</b>	147
36	DECALCOMANIE <b>(TE)</b>	TRANSFER <b>(TE)</b>	DECALCOMANIE <b>(TE)</b>	ABZIEHBILD <b>(TE)</b>	CALCOMANIA <b>(TE)</b>	151
37	DECALCOMANIE <b>(TC, TE-USA)</b>	TRANSFER <b>(TC, TE-USA)</b>	DECALCOMANIE <b>(TC, TE-USA)</b>	ABZIEHBILD <b>(TC, TE-USA)</b>	CALCOMANIA <b>(TC, TE-USA)</b>	153
38	DECALCOMANIE <b>(SMR)</b> (codice colore E)	TRANSFER <b>(SMR)</b> (color code E)	DECALCOMANIE <b>(SMR)</b> (code couleur E)	ABZIEHBILD <b>(SMR)</b> (Code Farbe E)	CALCOMANIA <b>(SMR)</b> (còdigo colòr E)	155
39	DECALCOMANIE <b>(SMR)</b> (codice colore F)	TRANSFER <b>(SMR)</b> (color code F)	DECALCOMANIE <b>(SMR)</b> (code couleur F)	ABZIEHBILD <b>(SMR)</b> (Code Farbe F)	CALCOMANIA <b>(SMR)</b> (còdigo colòr F)	157
-	INDICENUMERICOPROGRESSIVO	NUMERICALINDEX	INDEXNUMERIQUE	NUMMERNVERZEICHNIS	ÍNDICENUMÉRICOPROGRESIVO	158

Tavola - Drawing - Table - Bild - Tabla

**1**

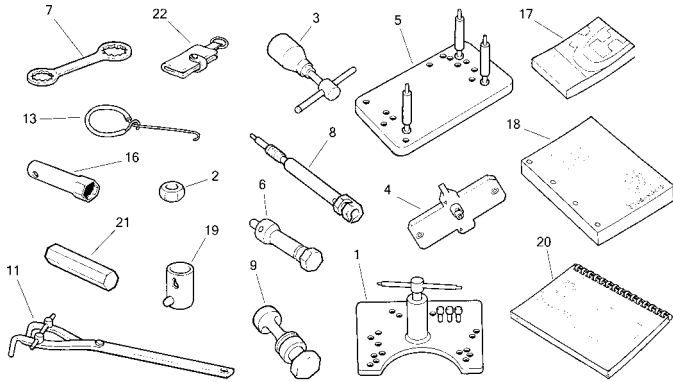

Pagina - Page - Page - Seite - Paja

**12**

Tavola - Drawing - Table - Bild - Tabla

**2**

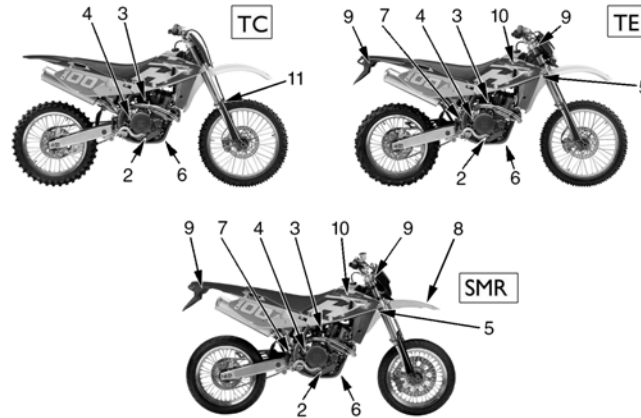

Pagina - Page - Page - Seite - Paja

**14**

Tavola - Drawing - Table - Bild - Tabla

**3**

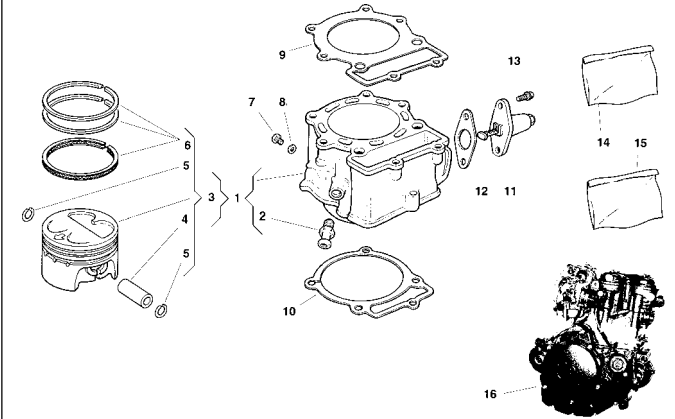

Pagina - Page - Page - Seite - Paja

**18**

Tavola - Drawing - Table - Bild - Tabla

**4**

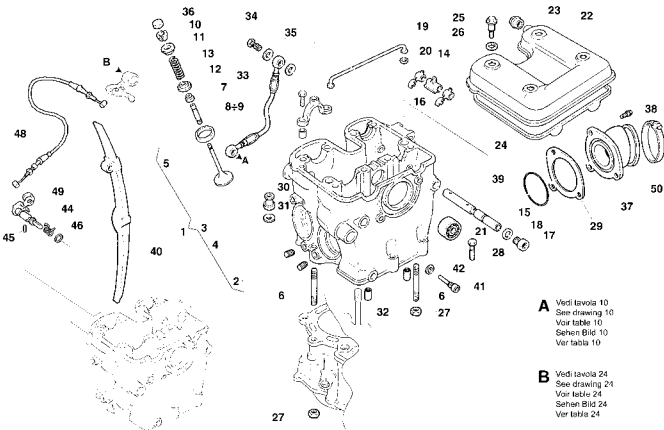

Pagina - Page - Page - Seite - Paja

**22**

Tavola - Drawing - Table - Bild - Tabla

**5**

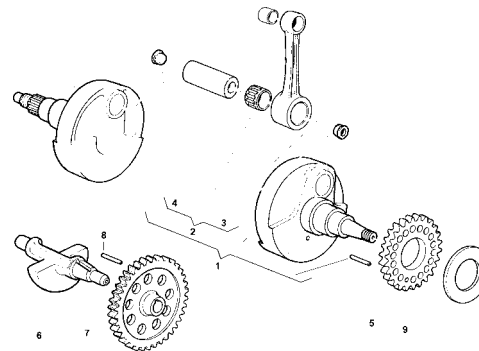

Pagina - Page - Page - Seite - Paja

**28**

Tavola - Drawing - Table - Bild - Tabla

**6**

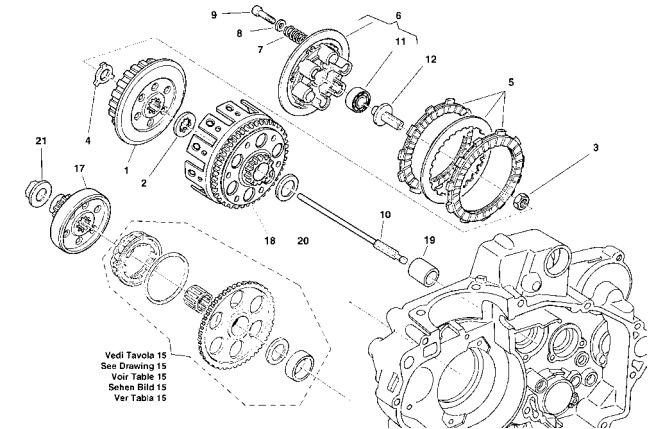

Pagina - Page - Page - Seite - Paja

**30**

Tavola - Drawing - Table - Bild - Tabla

7

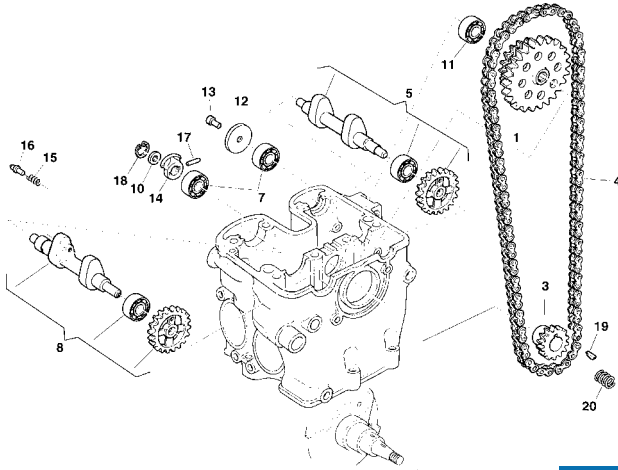

Pagina - Page - Page - Seite - Paja

32

Tavola - Drawing - Table - Bild - Tabla

8

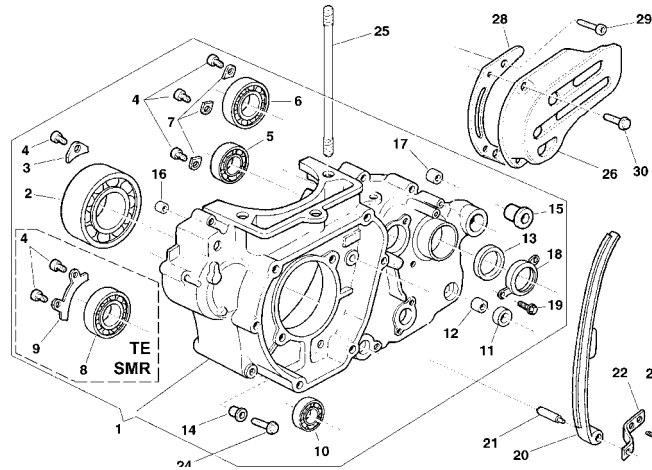

Pagina - Page - Page - Seite - Paja

36

Tavola - Drawing - Table - Bild - Tabla

9

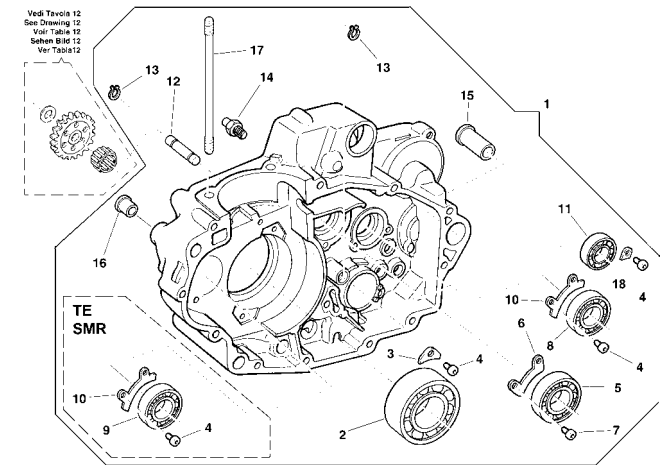

Pagina - Page - Page - Seite - Paja

40

Tavola - Drawing - Table - Bild - Tabla

10

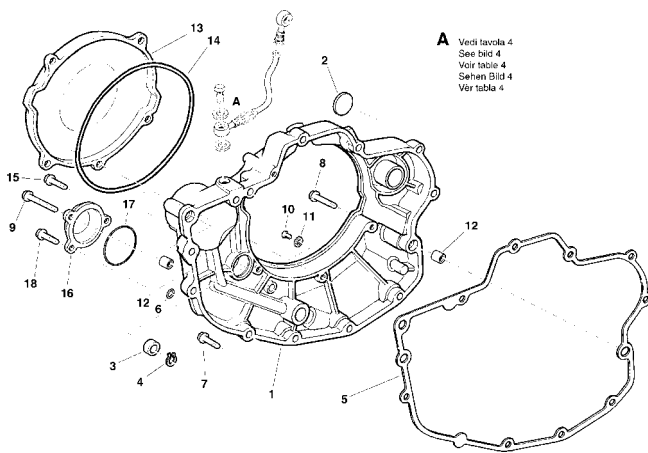

Pagina - Page - Page - Seite - Paja

42

Tavola - Drawing - Table - Bild - Tabla

11

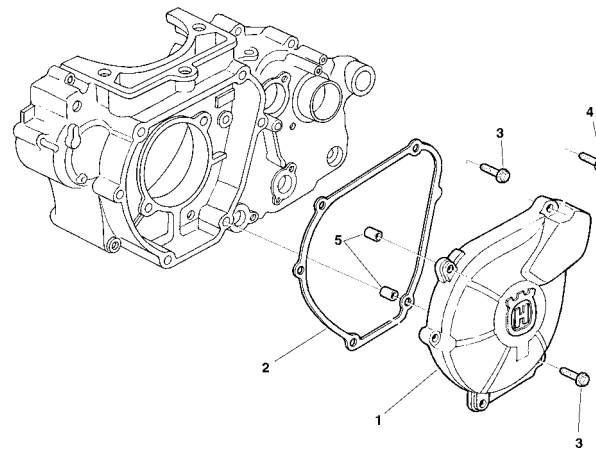

Pagina - Page - Page - Seite - Paja

44

Tavola - Drawing - Table - Bild - Tabla

12

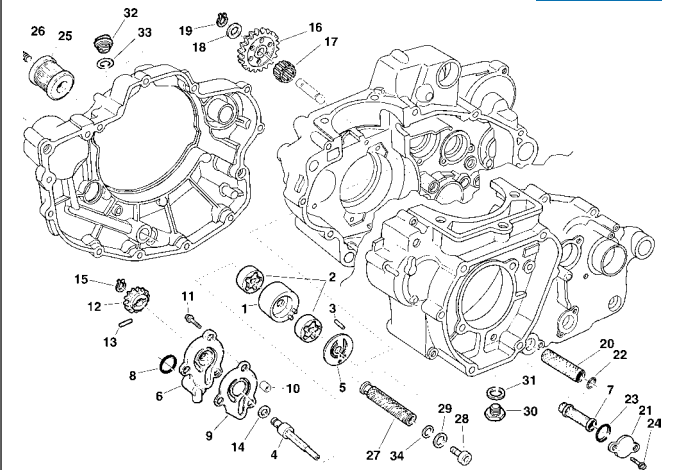

Pagina - Page - Page - Seite - Paja

46



Tavola - Drawing - Table - Bild - Tabla

**13**

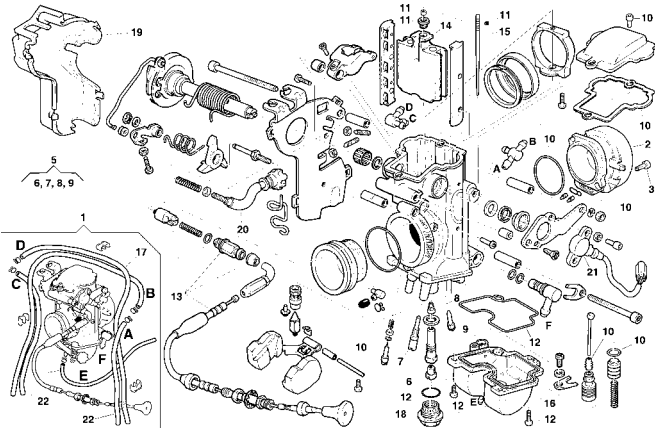

Pagina - Page - Page - Seite - Paja

**50**

Tavola - Drawing - Table - Bild - Tabla

**14**

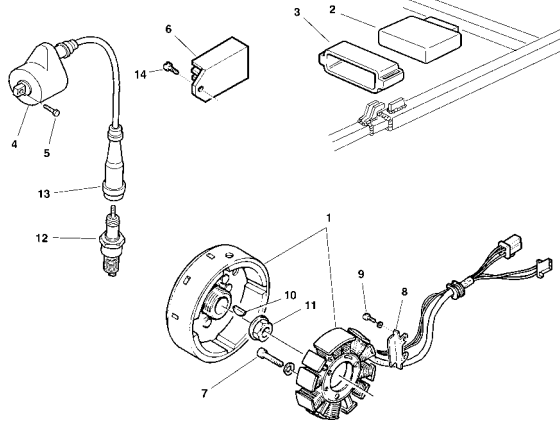

Pagina - Page - Page - Seite - Paja

**56**

Tavola - Drawing - Table - Bild - Tabla

**15**

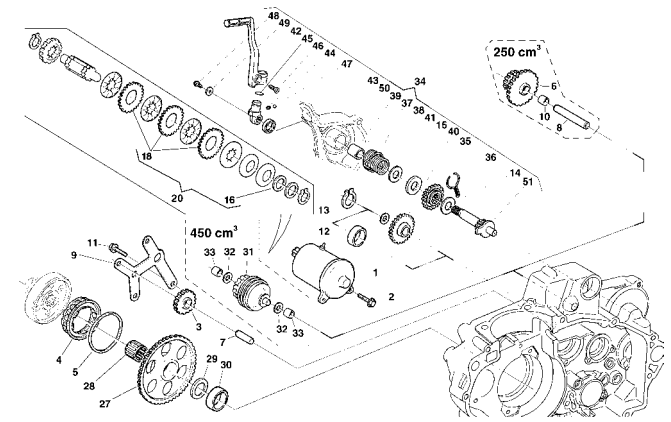

Pagina - Page - Page - Seite - Paja

**58**

Tavola - Drawing - Table - Bild - Tabla

**16**

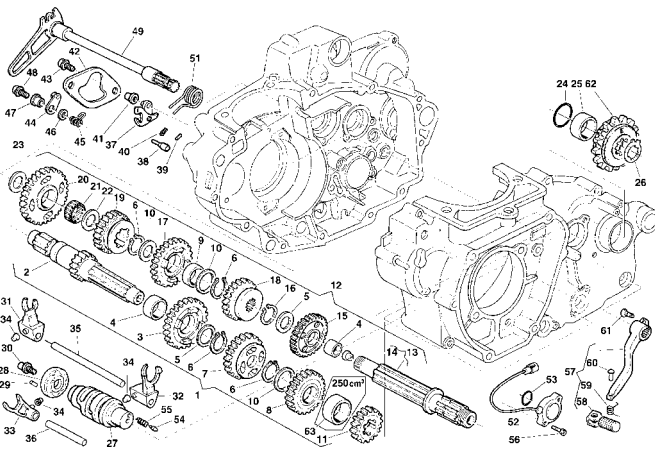

Pagina - Page - Page - Seite - Paja

**62**

Tavola - Drawing - Table - Bild - Tabla

**16A**

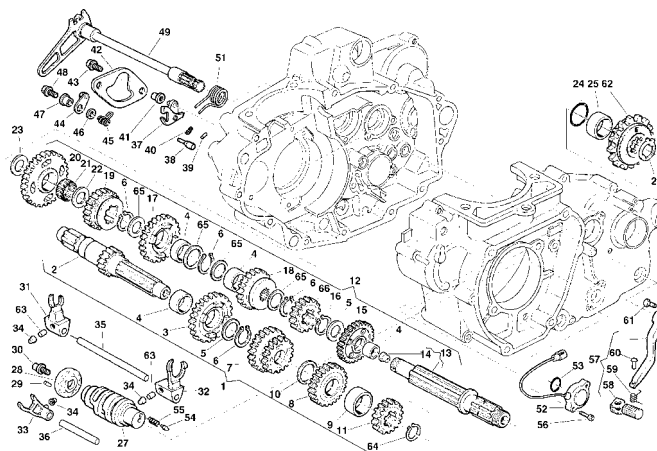

Pagina - Page - Page - Seite - Paja

**70**

Tavola - Drawing - Table - Bild - Tabla

**17**

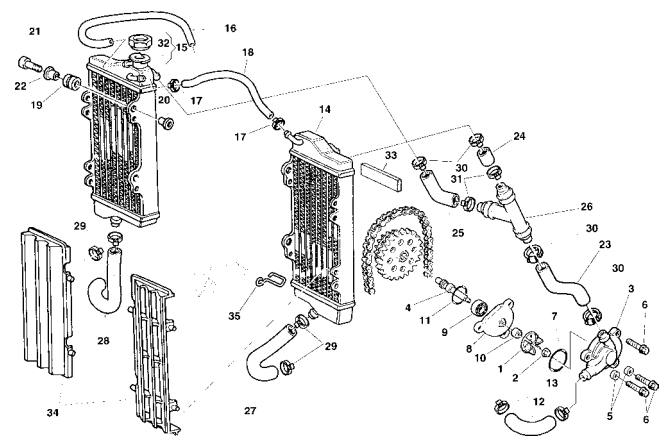

Pagina - Page - Page - Seite - Paja

**76**

Tavola - Drawing - Table - Bild - Tabla

**18**

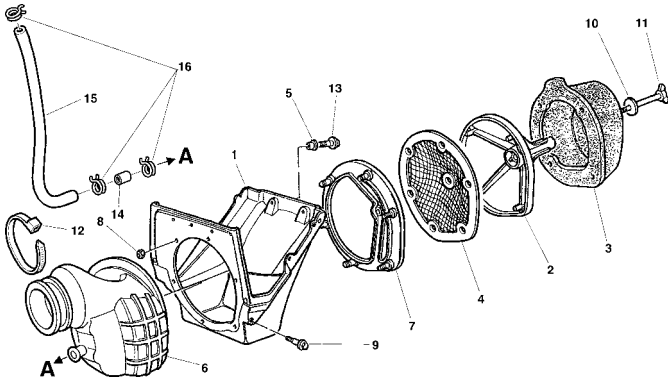

Pagina - Page - Page - Seite - Paja

**80**

Tavola - Drawing - Table - Bild - Tabla

**19**

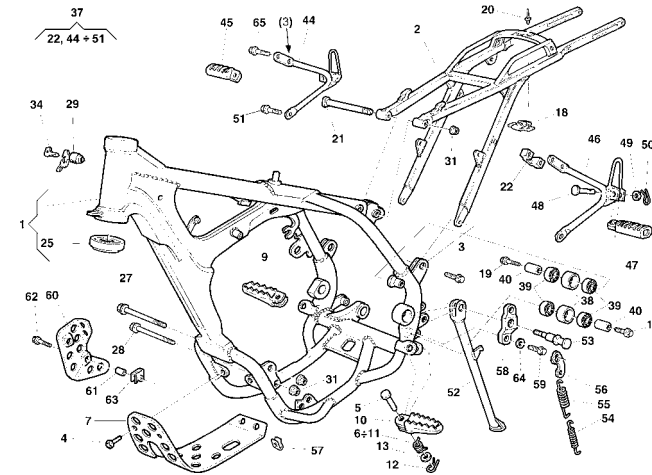

Pagina - Page - Page - Seite - Paja

**82**

Tavola - Drawing - Table - Bild - Tabla

**20**

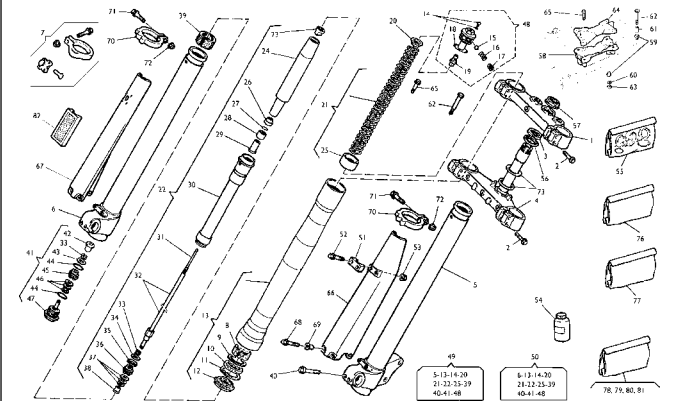

Pagina - Page - Page - Seite - Paja

**86**

Tavola - Drawing - Table - Bild - Tabla

**21**

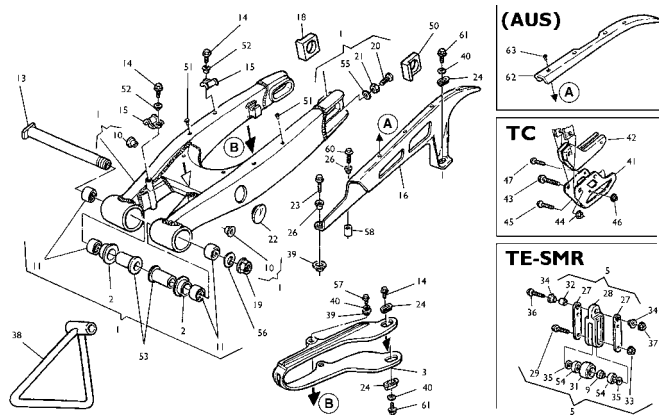

Pagina - Page - Page - Seite - Paja

**94**

Tavola - Drawing - Table - Bild - Tabla

**22**

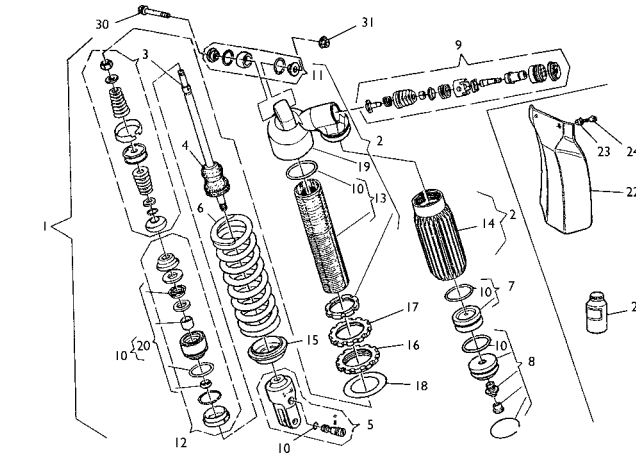

Pagina - Page - Page - Seite - Paja

**98**

Tavola - Drawing - Table - Bild - Tabla

**23**

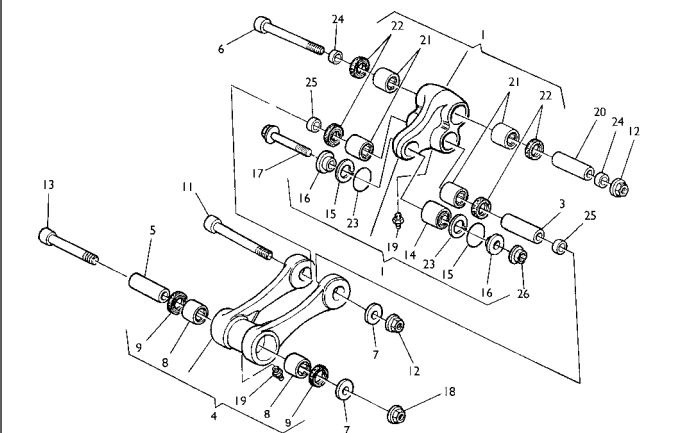

Pagina - Page - Page - Seite - Paja

**102**

**Tavola - Drawing - Table - Bild - Tabla**

**24**

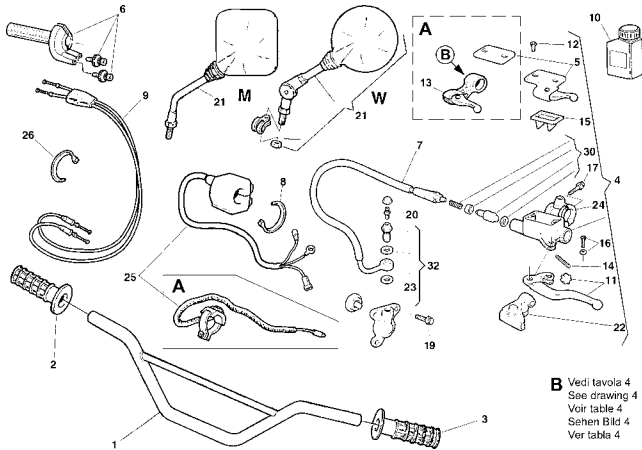

**Pagina - Page - Page - Seite - Paja**

**104**

**Tavola - Drawing - Table - Bild - Tabla**

**25**

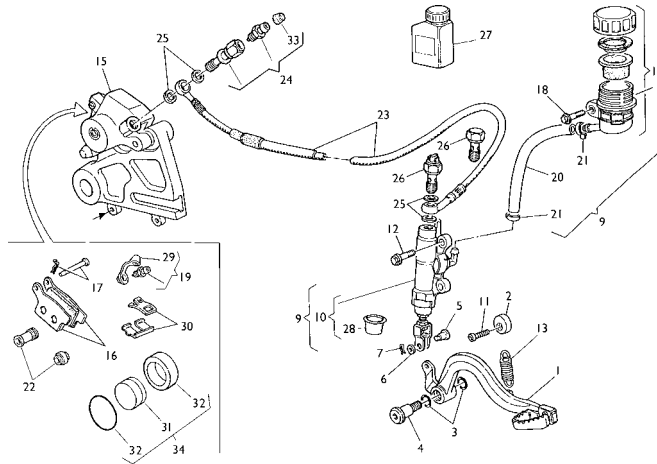

**Pagina - Page - Page - Seite - Paja**

**108**

**Tavola - Drawing - Table - Bild - Tabla**

**26**

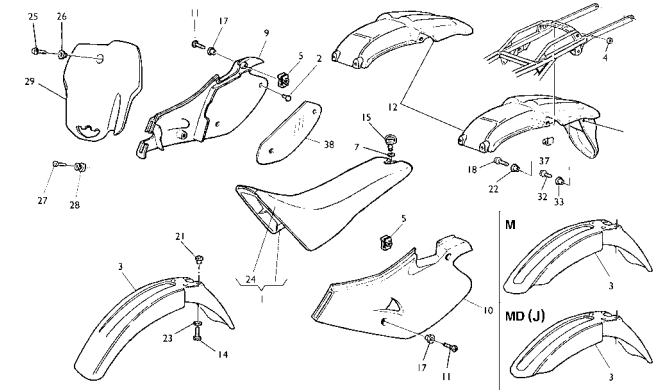

**Pagina - Page - Page - Seite - Paja**

**112**

**Tavola - Drawing - Table - Bild - Tabla**

**27**

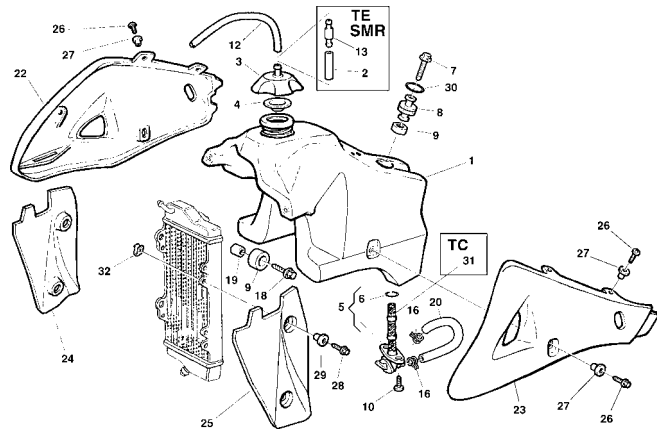

**Pagina - Page - Page - Seite - Paja**

**116**

**Tavola - Drawing - Table - Bild - Tabla**

**28**

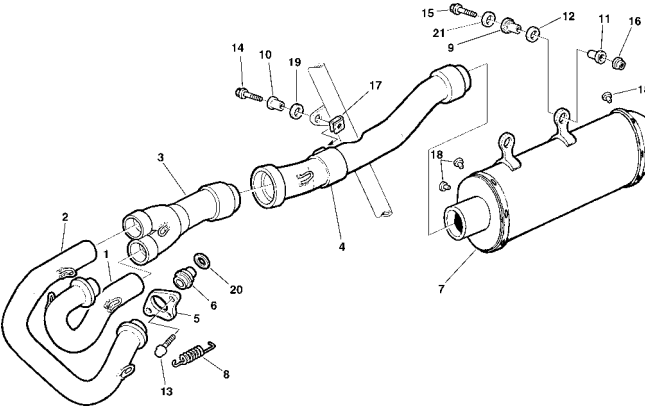

**Pagina - Page - Page - Seite - Paja**

**120**

**Tavola - Drawing - Table - Bild - Tabla**

**29**

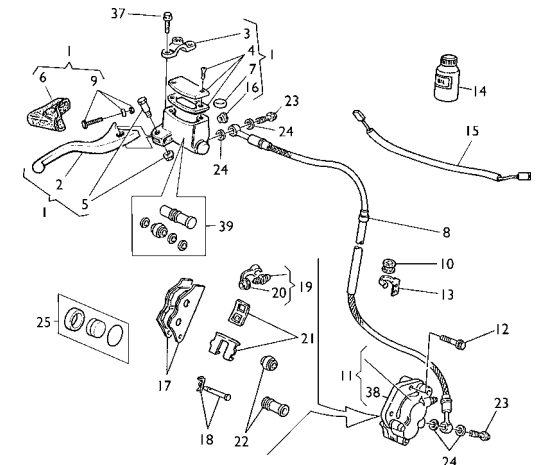

**Pagina - Page - Page - Seite - Paja**

**124**



Tavola - Drawing - Table - Bild - Tabla

29A

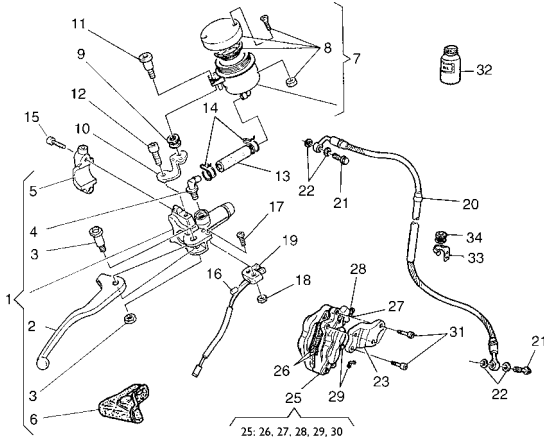

Pagina - Page - Page - Seite - Paja

126

Tavola - Drawing - Table - Bild - Tabla

30

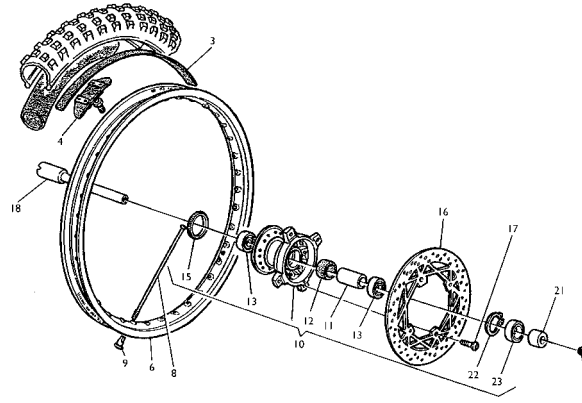

Pagina - Page - Page - Seite - Paja

128

Tavola - Drawing - Table - Bild - Tabla

30A

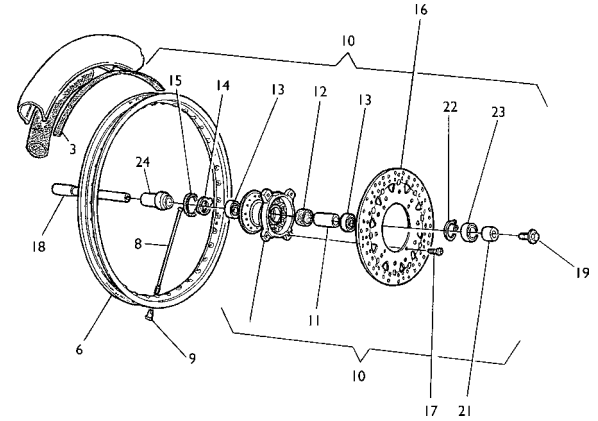

Pagina - Page - Page - Seite - Paja

130

Tavola - Drawing - Table - Bild - Tabla

31

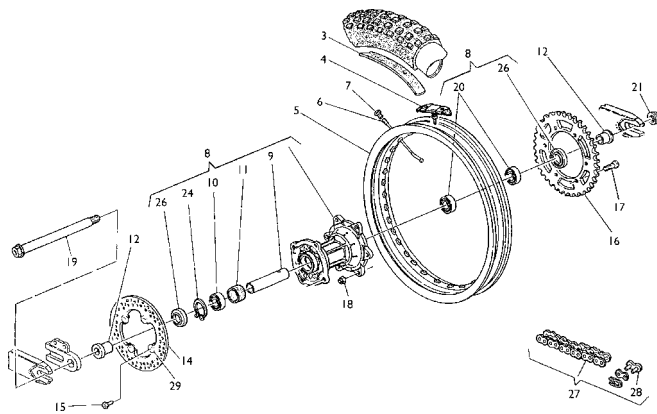

Pagina - Page - Page - Seite - Paja

132

Tavola - Drawing - Table - Bild - Tabla

32

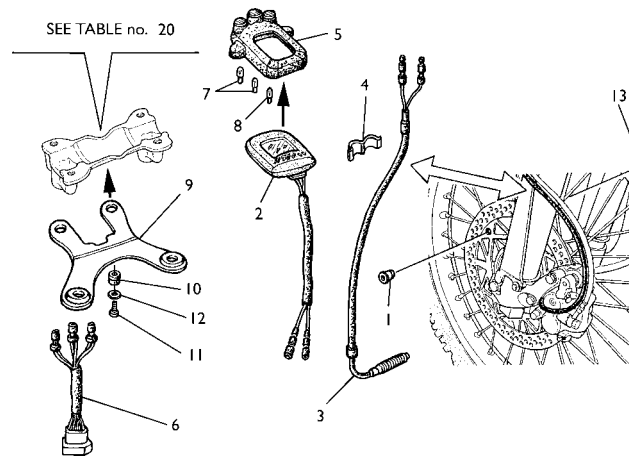

Pagina - Page - Page - Seite - Paja

136

Tavola - Drawing - Table - Bild - Tabla

33

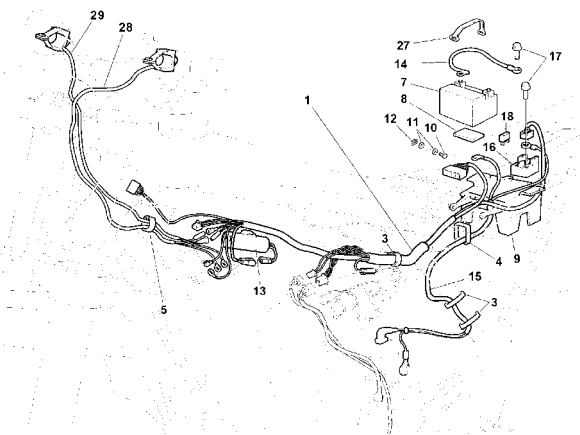

Pagina - Page - Page - Seite - Paja

138

Tavola - Drawing - Table - Bild - Tabla

33A

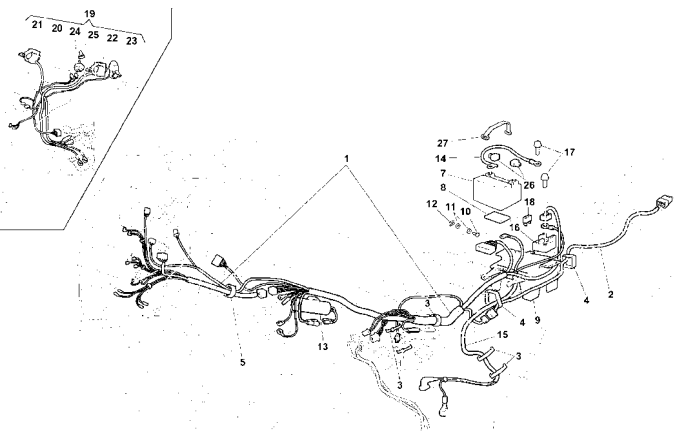

Pagina - Page - Page - Seite - Paja

140

Tavola - Drawing - Table - Bild - Tabla

33B

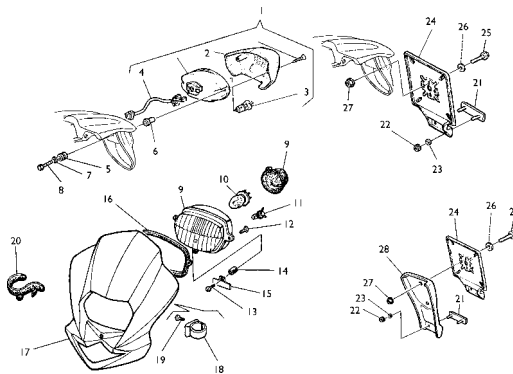

Pagina - Page - Page - Seite - Paja

142

Tavola - Drawing - Table - Bild - Tabla

34

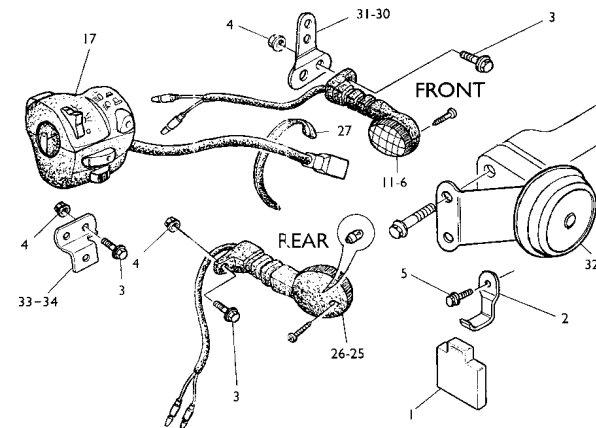

Pagina - Page - Page - Seite - Paja

144

Tavola - Drawing - Table - Bild - Tabla

35

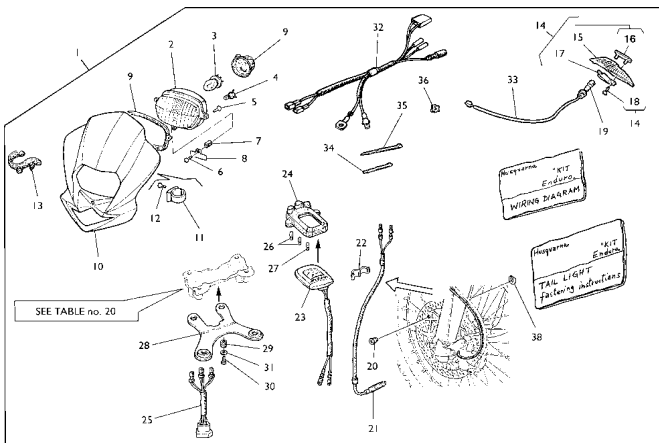

Pagina - Page - Page - Seite - Paja

146

Tavola - Drawing - Table - Bild - Tabla

36



Pagina - Page - Page - Seite - Paja

150

Tavola - Drawing - Table - Bild - Tabla

37



Pagina - Page - Page - Seite - Paja

152

Tavola - Drawing - Table - Bild - Tabla

38



Pagina - Page - Page - Seite - Paja

154

Tavola - Drawing - Table - Bild - Tabla

39



Pagina - Page - Page - Seite - Paja

156

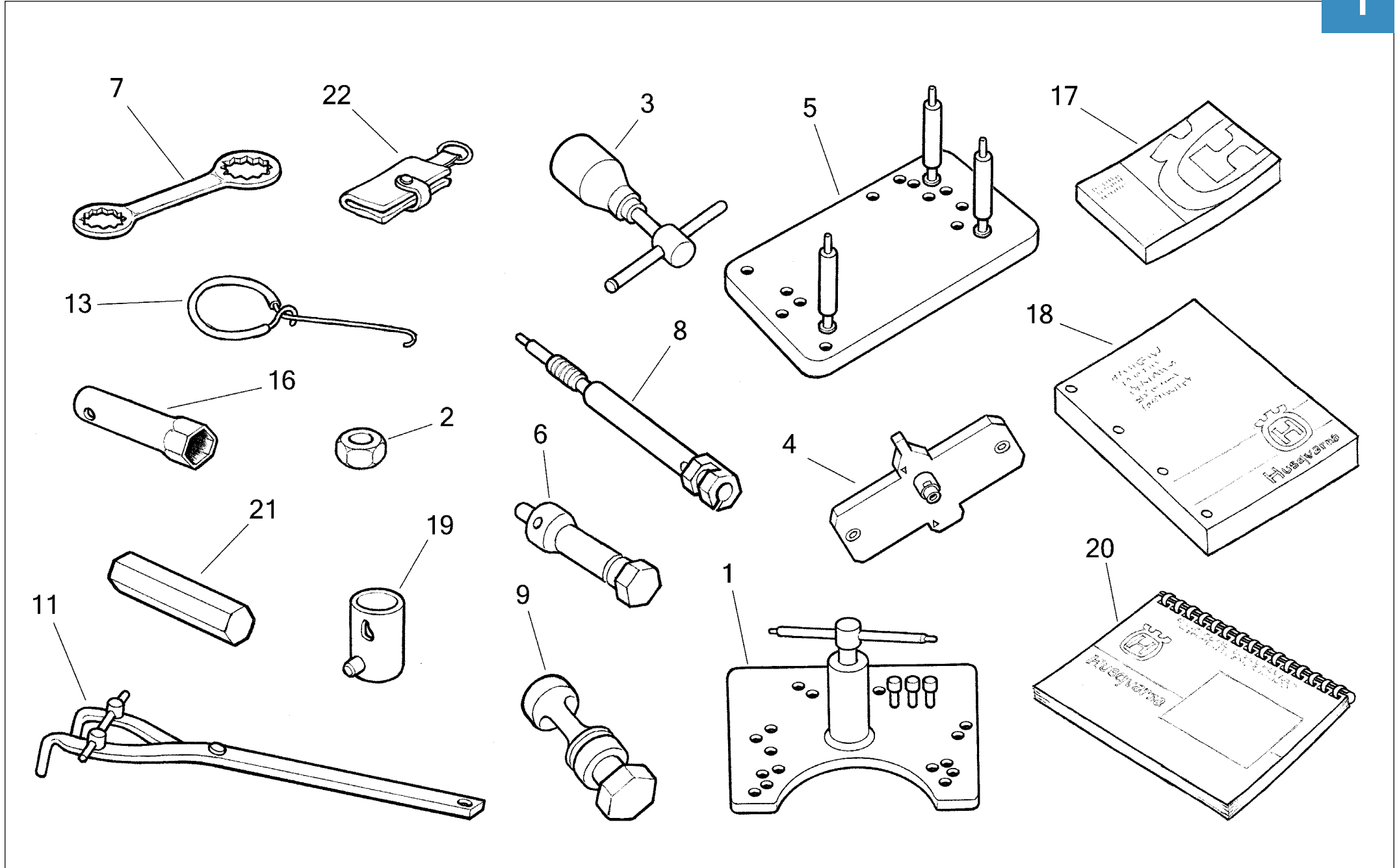





**TC-TE 250- 450,  
SM 400R-450R/ 2004**

TAVOLA  
DRAWING  
TABLE  
BILD  
TABLA

**1**

**ATTREZZI DI ASSISTENZA, MANUALI E CATALOGHI - SERVICE TOOLS, MANUALS AND CATALOGS  
OUTILS D'ASSISTANCE, MANUELS ET CATALOGUES - HILFAUSRÜSTUNG, HANDBUCH UND KATALOG  
HERRAMIENTAS DE ASISTENCIA, MANUALES Y CATALOGOS**

Note Notes Marke Notas	Pos. No. N. Index Pos.	N. Cod. Code No. Nr. Code Code Nr N. Cod.	Q.tà Q.ty Q.té M.ge C.ad	DENOMINAZIONE	NAME	DESIGNATION	BESHREIBUNG	DENOMINACION	Validità Validity Validité Gültig Validez
	1	1517 94702	1	Estrattore basamento	Crankcase puller	Extracteur carter	Kurbelgehäuse-Auszieher	Extractor cárter	
	2	8000 A1580		Protezione alb. motore	Crankshaft guard	Protection vilebrequin	Schutz für Kurbewelle	Protección por cigueñal	
	3	8000 A1559	1	Estrattore volano	Flywheel extractor	Extracteur pour volant	Auszieher für Schwungrad	Extractor volante	
	4	8000 A1512		Attrezzo contr. accensione	Ignition checking tool	Outil contrôle allumage	Kontrollwerkzeug für Zündung	Herramienta control encendido	
	5	8A00 90622	1	Supporto per montaggio	Support for assy	Support pour montage	Halterung für Montage	Soporte por el montaje	
	6	8000 A1576		Attrezzo mont. semiconi	Half cone assembling tool	Outil montage demi-cône	Werkzeug für montage der Half-Kebel	Herramienta montaje semi-conos	
<b>D</b>	7	8000 66802	1	Chiave poligonale	Poligonal wrench	Cléf polygonale	Sechskantschlüssel	Llave poligonal	
	8	8000 A1625		Attrezzo portacomparatore	Dial gauge holding tool	Outil support comparateur	Werkzeug Komparatorhalter	Herramienta porta comparador	
	9	8000 A1579		Attrezzo smont. semiconi	Half cone disassembling tool	Outil demontage demi-cône	Werkzeug für Ausbau der Half-Kebel	Herramienta desmontaje semi-conos	
	11	8000 79015	1	Chiave di fermo mozzo frizione	Clutch hub retaining wrench	Cléf d'arret moyeau embrayage	Halterungsschlüssel der Kupplungsnabe	Llave bloquear cubo fricción	
	13	1519 84701	1	Gancio per molle	Spring hook	Crochet pour ressort	Federhaken	Gancho para resorte	
<b>D</b>	16	8000 95749	1	Chiave candela	Spark plug wrench	Cléf bougie	Zündkerzeschlüssel	Llave bujia	
<b>D</b>	17	8000 A2924	1	Libretto uso e manuten.	Owner's manual	Emploi d'entretien	Betriebsanleitung	Manual uso y manten.	
<b>R</b>	18	8000 A2925	1	Manuale di officina	Workshop manual	Mauel d'atelier	Werkstatthandbuch	Manual de oficina	
<b>D</b>	19	8000 96997	1	Chiave perno ruota anteriore	Front wheel axle wrench	Cléf pivot roue avant	Vorterrad bolzen schlüssel	Llave perno rueda delantera	
<b>R</b>	20	8000 A2926	1	Catalogo PARTI DI RICAMBIO	SPARE PARTS catalog	Catalogue PIECES DE RECHANGE	ERSATZTEILKATALOG	Catalogo PIEZAS DE REPUESTO	
<b>D</b>	21	8000 56920	1	Chiave esagonale per vite perno ruota anteriore	Front wheel axle screw Allen wrench	Clef à douille pour vis de pivot roue avant	Sechs Kantschlüssel für Vorderradbolzen schraube	Llave hexagonal por tornillo perno rueda delantera	
<b>DW</b>	22	8000 97615	1	Porta chiavi	Key-ring	Porte-clefs	Schlüsselring	Llavero	

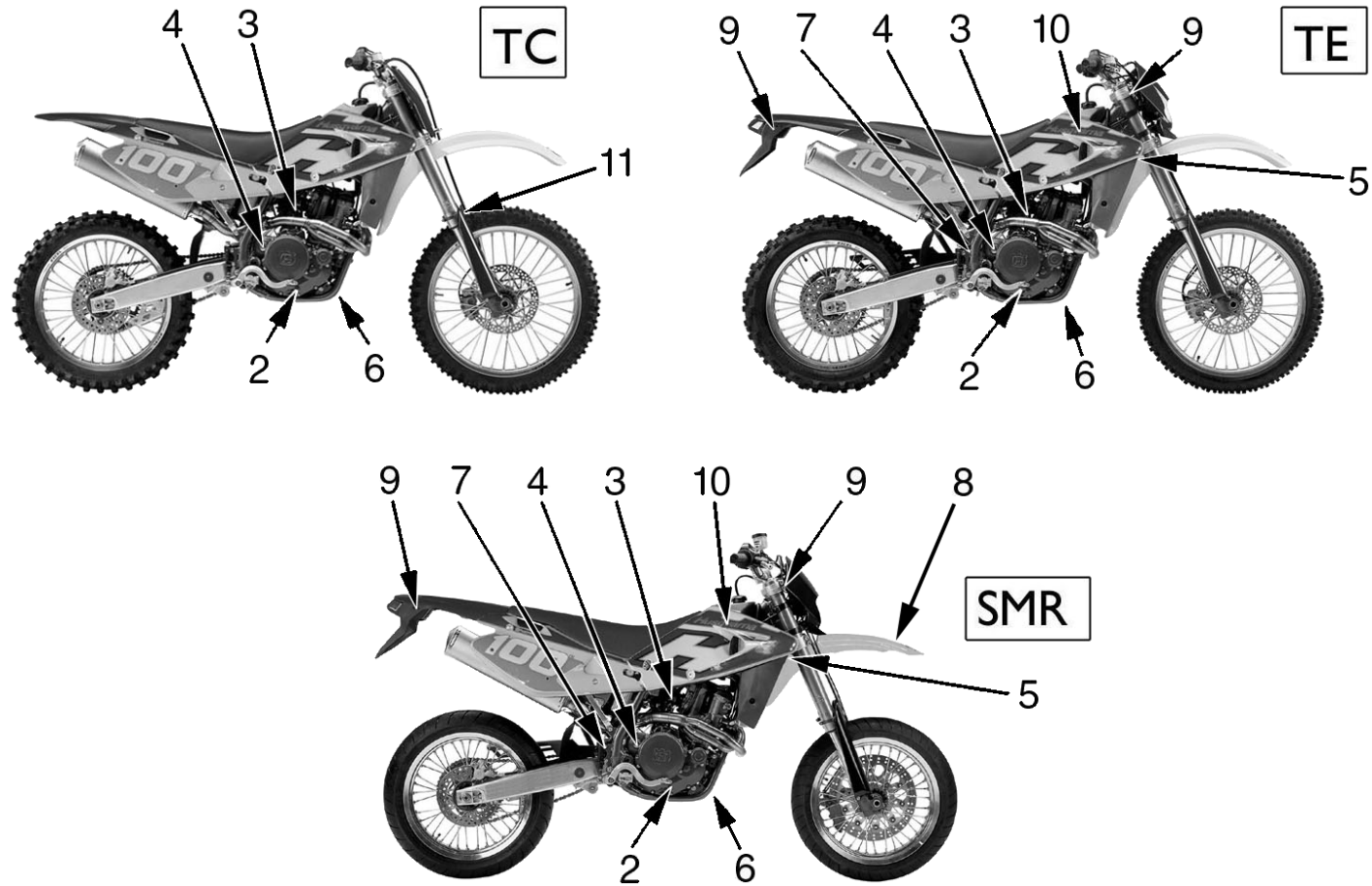



**TC-TE 250- 450,  
SM 400R-450R/ 2004**

TAVOLA  
DRAWING  
TABLE  
BILD  
TABLA

**2**

**KIT IN DOTAZIONE- EQUIPMENT KITS- KITS EN NECESSAIRE-  
AUSRÜDTUNGSTEILE KIT- KIT EN DOTACION**

Note Notes Marke Notas	Pos. No. N. Index Pos.	N. Cod. Code No. Nr. Code Code Nr N. Cod.	Q.tà Q.ty Q.te M.ge C.ad	DENOMINAZIONE	NAME	DESIGNATION	BESHREIBUNG	DENOMINACION	Validità Validity Validité Gültig Validez
	2	8000 A1427	1	Protezione carter destro (TE-TC 250, 450) (Pos. 60 TAVOLA 19)	R.H. crankcase guard (TE-TC 250, 450) (No. 60 DRAWING 19)	Protection couvercle carter D. (TE-TC 250, 450) (N. 60 TABLE 19)	R. Gehäusedeckel Schutz (TE-TC 250, 450) (Index 60 BILD 19)	Protección tapabancada der. (TE-TC 250, 450) (Pos. 60 TABLA 19)	
	3	8000 A1822	1	Kit carburat. MIKUNI TMR 36 (TE 250) (Pos. 5 TAVOLA 13)	Carburetor kit (TE 250) (No. 5 DRAWING 13)	Kit carburateur (TE 250) (N. 5 TABLE 13)	Vergaser Kit (TE 250) (Index 5 BILD 13)	Kit carburador (TE 250) (Pos. 5 TABLA 13)	
	3	8000 A1823	1	Kit carburat. MIKUNI TMR 38 (TC 250) (Pos. 5 TAVOLA 13)	Carburetor kit (TC 250) (No. 5 DRAWING 13)	Kit carburateur (TC 250) (N. 5 TABLE 13)	Vergaser Kit (TC 250) (Index 5 BILD 13)	Kit carburador (TC 250) (Pos. 5 TABLA 13)	
	3	8000 A3091	1	Kit carburat. MIKUNI TMR 38 (SMR 400) (Pos. 5 TAVOLA 13)	Carburetor kit (SMR 400) (No. 5 DRAWING 13)	Kit carburateur (SMR 400) (N. 5 TABLE 13)	Vergaser Kit (SMR 400) (Index 5 BILD 13)	Kit carburador (SMR 400) (Pos. 5 TABLA 13)	
	3	8000 A1824	1	Kit carburat. MIKUNI TMR 41 (TE-TC-SMR 450) (Pos. 5 TAVOLA 13)	Carburetor kit (TE-TC-SMR 450) (No. 5 DRAWING 13)	Kit carburateur (TE-TC-SMR 450) (N. 5 TABLE 13)	Vergaser Kit (TE-TC-SMR 450) (Index 5 BILD 13)	Kit carburador (TE-TC-SMR 450) (Pos. 5 TABLA 13)	
	4	8000 A3016	1	Kit avviamento a pedale (Pos. 34 TAVOLA 15)	Kick starter kit (No. 34 DRAWING 15)	Kit démarrage à pédale (N. 34 TABLE 15)	Kit Kickstarter (Index 34 BILD 15)	Kit arranque a pedal (Pos. 34 TABLA 15)	
	6	8000 A0865	1	Paramotore (Pos. 7 TAVOLA 19)	Engine guard (No. 7 DRAWING 19)	Garde moteur (N. 7 TABLE 19)	Motorschutz (Index 7 BILD 19)	Para motor (Pos. 7 TABLA 19)	

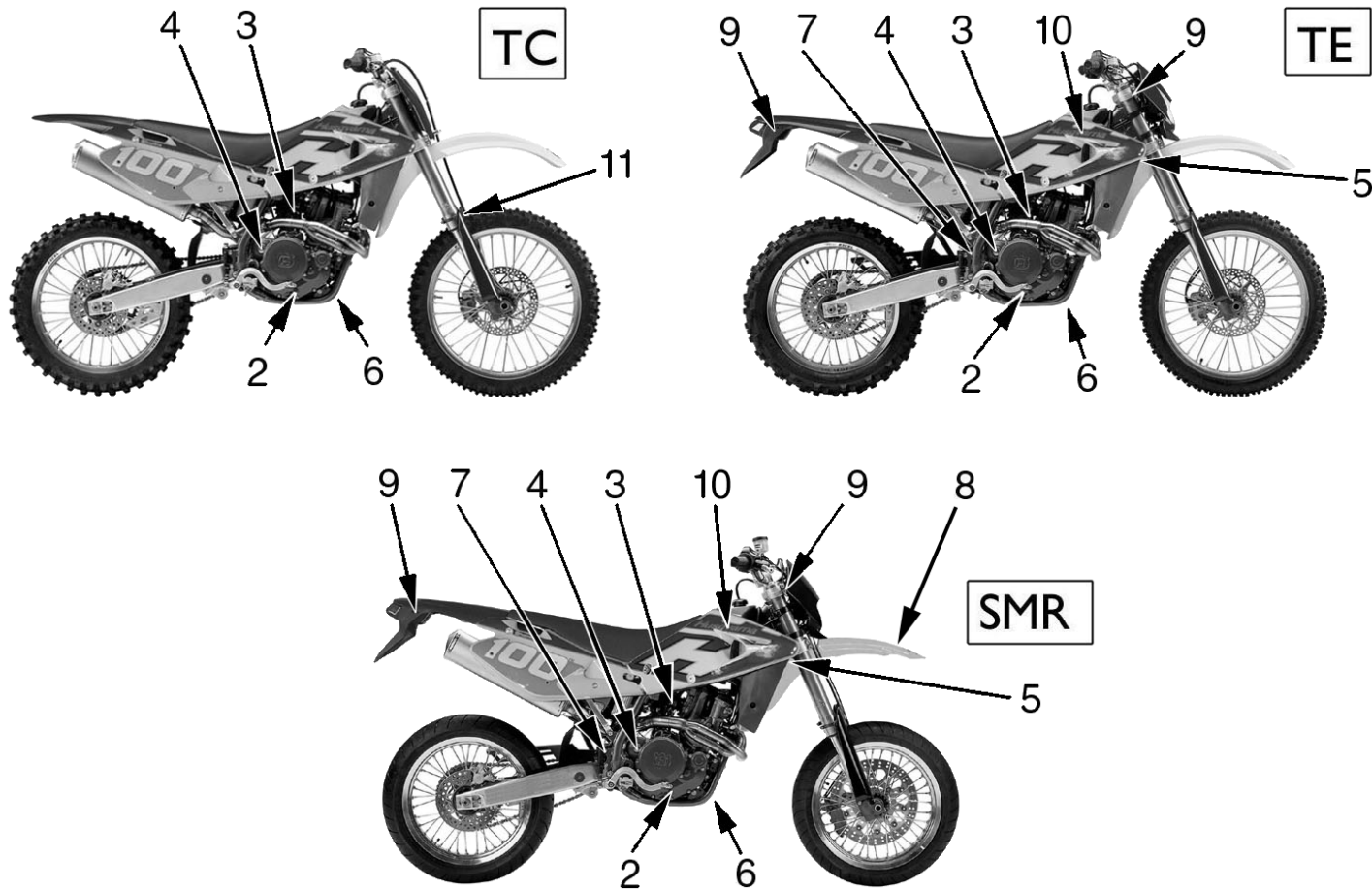





**TC-TE 250- 450,  
SM 400R-450R/ 2004**

TAVOLA  
DRAWING  
TABLE  
BILD  
TABLA

**2**

**KIT IN DOTAZIONE- EQUIPMENT KITS- KITS EN NECESSAIRE-  
AUSRUDTUNGSTEILE KIT- KIT EN DOTACION**

Note Notes Marken Notas	Pos. No. N. Index Pos.	N. Cod. Code No. Nr. Code Code Nr N. Cod.	Q.tà Q.ty Q.te M.ge C.ad	DENOMINAZIONE	NAME	DESIGNATION	BESHREIBUNG	DENOMINACION	Validità Validity Validité Gültig Validez
<b>X</b>	7	8000 A0677	1	Kit compl. poggiapiedi (TE 250, TE 450 - SMR) (Pos. 37 TAVOLA 19)	Compl. footrest Kit (TE 250, TE 450 - SMR) (No. 37 DRAWING 19)	Appui-pied complet (TE 250, TE 450 - SMR) (N. 37 TABLE 19)	kompl. Fussraster-Kit (TE 250, TE 450 - SMR) (Index 37 BILD 19)	Kit compl. apoyapiés (TE 250, TE 450 - SMR) (Pos. 37 TABLA 19)	
	8	8A00 98534	1	Parafango ant. (SMR 400) (codice colore E) (Pos. 3 TAVOLA 26)	Front mudguard (SMR 400) (color code E) (No. 3 DRAWING 26)	Garde-boue avant (SMR 400) (code couleur E) (N. 3 TABLE 26)	Vord. Kotfluegel (SMR 400) (Code Farbe E) (Index 3 BILD 26)	Guarda-barros del. (SMR 400) (còdigo colòr E) (Pos. 3 TABLA 26)	
	8	8000 A1761	1	Parafango ant. (SMR 450) (codice colore E) (Pos. 3 TAVOLA 26)	Front mudguard (SMR 450) (color code E) (No. 3 DRAWING 26)	Garde-boue avant (SMR 450) (code couleur E) (N. 3 TABLE 26)	Vord. Kotfluegel (SMR 450) (Code Farbe E) (Index 3 BILD 26)	Guarda-barros del. (SMR 450) (còdigo colòr E) (Pos. 3 TABLA 26)	
	8	80A0 A1761	1	Parafango ant. (SMR 450) (codice colore G) (Pos. 3 TAVOLA 26)	Front mudguard (SMR 450) (color code G) (No. 3 DRAWING 26)	Garde-boue avant (SMR 450) (code couleur G) (N. 3 TABLE 26)	Vord. Kotfluegel (SMR 450) (Code Farbe G) (Index 3 BILD 26)	Guarda-barros del. (SMR 450) (còdigo colòr G) (Pos. 3 TABLA 26)	
<b>X</b>	9	8B00 A0226	1	Kit indicatori di direzione (TE 250, TE 450 - SMR) (Pos. 6, 11, 25, 26 TAV. 34)	Blinkers Kit (TE 250, TE 450 - SMR) (No. 6, 11, 25, 26DRAW. 34)	Kit clignotants (TE 250, TE 450 - SMR) (N. 6, 11, 25, 26 TABLE 34)	Blinkers Kit (TE 250, TE 450 - SMR) (Index 6, 11, 25, 26 BILD 34)	Kit intermitentes (TE 250, TE 450 - SMR) (Pos. 6, 11, 25, 26TABLA 34)	
<b>RW</b>	10	8000 A1882	1	Kit cablaggio RACING (Pos. 19 TAVOLA 33A)	RACING main wiring harness (No. 19 DRAWING 33A)	Kit cables RACING (N. 19 TABLE 33A)	RACING Kabel Kit (Index 19 BILD 33A)	Kit grupo cables RACING (Pos. 19 TABLA 33A)	
	11	8000 A3191	1	Kit gancio partenza (TC 250-450) (Pos. 7 TAVOLA 20)	Kit starting hook (TC 250-450) (No. 7 DRAWING 20)	Kit crochet pour départ (TC 250-450) (N. 7 TABLE 20)	Abfahrthacken (TC 250-450) (Index 7 BILD 20)	Gancho por salida (TC 250-450) (Pos. 7 TABLA 20)	

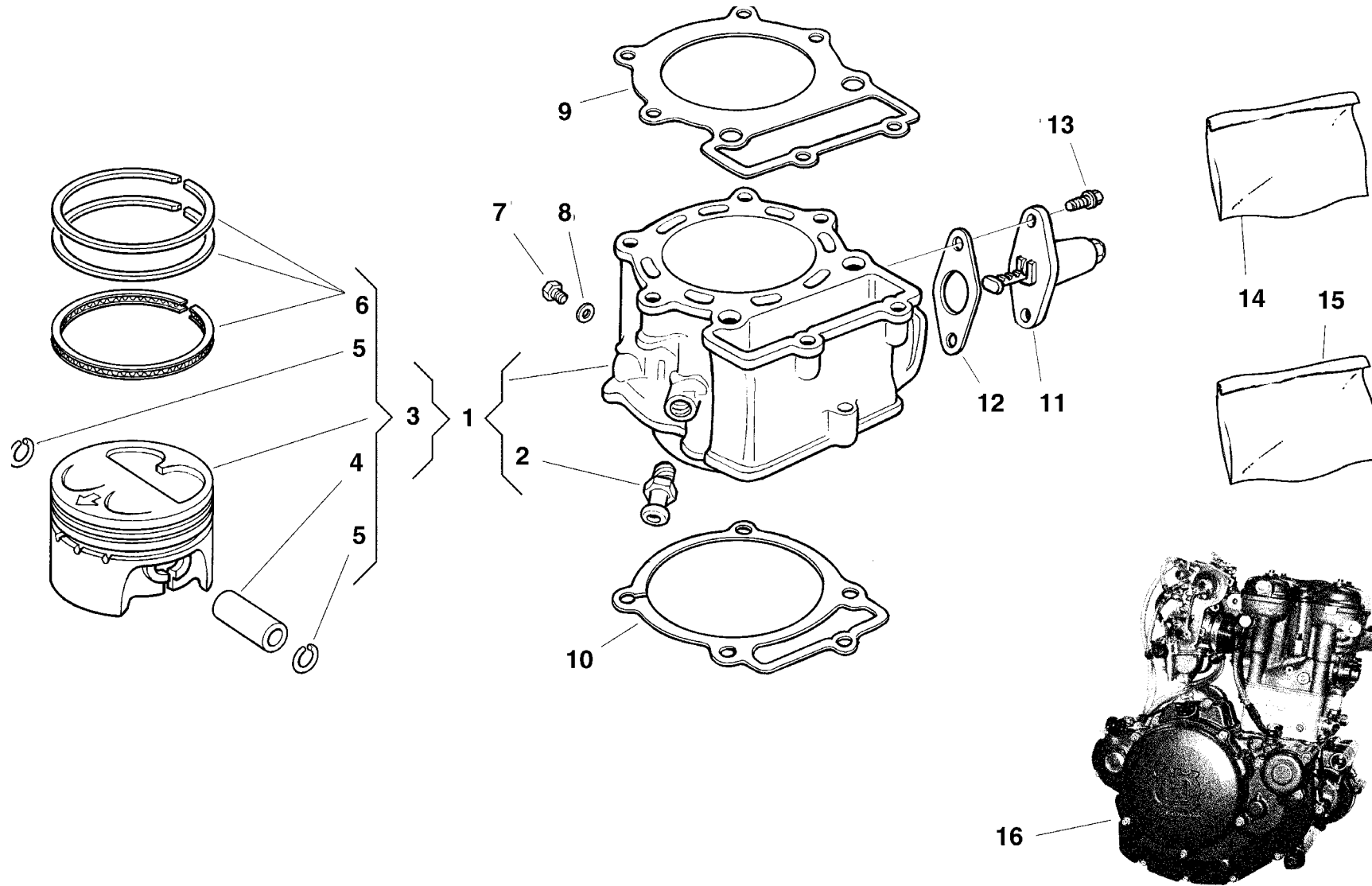

Note Notes Notas Markes	Pos. No. N. Index Pos.	N. Cod. Code No. Nr. Code Code Nr N. Cod.	Q.tà Q.ty M.ge C.ad	DENOMINAZIONE	NAME	DESIGNATION	BESHREIBUNG	DENOMINACION	Validità Validity Validité Gültig Validez
	1	8000 99801	1	Cilindro completo (250)	Cylinder assy (250)	Cylindre compl. (250)	Zylinder kpl. (250)	Cilindro compl. (250)	
	1	8000 99869	1	Cilindro completo (400)	Cylinder assy (400)	Cylindre compl. (400)	Zylinder kpl. (400)	Cilindro compl. (400)	
	1	8000 A2980	1	Cilindro completo (450)	Cylinder assy (450)	Cylindre compl. (450)	Zylinder kpl. (450)	Cilindro compl. (450)	
<b>A</b>	1	8000 A0001	1	Cilindro completo (450)	Cylinder assy (450)	Cylindre compl. (450)	Zylinder kpl. (450)	Cilindro compl. (450)	
	2	8000 63885	2	Raccordo	Union	Raccord	Anschluss	Empalme	
<b>E</b>	3	8000 99803	1	Pistone completo (Ø 76 mm) (250)	Piston assy. (Ø 76 mm) (250)	Piston complet (Ø 76 mm) (250)	Kolben, kpl. (Ø 76 mm) (250)	Pistón completo (Ø 76 mm) (250)	
<b>A</b>	3	8000 A0604	1	Pistone completo (Ø 76 mm) (250)	Piston assy. (Ø 76 mm) (250)	Piston complet (Ø 76 mm) (250)	Kolben, kpl. (Ø 76 mm) (250)	Pistón completo (Ø 76 mm) (250)	
	3	8000 99870	1	Pistone completo (Ø 91,5 mm) (400)	Piston assy. (Ø 91,5 mm) (400)	Piston complet (Ø 91,5 mm) (400)	Kolben, kpl. (Ø 91,5 mm) (400)	Pistón completo (Ø 91,5 mm) (400)	
	3	8000 A0006	1	Pistone completo (Ø 97 mm) (450)	Piston assy. (Ø 97 mm) (450)	Piston complet (Ø 97 mm) (450)	Kolben, kpl. (Ø 97 mm) (450)	Pistón completo (Ø 97 mm) (450)	
<b>A</b>	3	8000 A0852	1	Pistone completo (Ø 97 mm) (450)	Piston assy. (Ø 97 mm) (450)	Piston complet (Ø 97 mm) (450)	Kolben, kpl. (Ø 97 mm) (450)	Pistón completo (Ø 97 mm) (450)	
<b>E</b>	4	8000 98027	1	Spinotto (250)	Gudgeon (250)	Axe (250)	Bolzen (250)	Perno (250)	
<b>A&amp;</b>	4	8000 A0606	1	Spinotto (250)	Gudgeon (250)	Axe (250)	Bolzen (250)	Perno (250)	
	4	8000 99871	1	Spinotto (400)	Gudgeon (400)	Axe (400)	Bolzen (400)	Perno (400)	
	4	8000 A0008	1	Spinotto (450)	Gudgeon (450)	Axe (450)	Bolzen (450)	Perno (450)	
<b>A£</b>	4	8000 A0854	1	Spinotto (450)	Gudgeon (450)	Axe (450)	Bolzen (450)	Perno (450)	
<b>E</b>	5	8000 98028	2	Anello di fermo (250)	Stop ring (250)	Bague d'arrêt (250)	Haltering (250)	Anillo de retención (250)	
<b>A&amp;</b>	5	8000 A2714	2	Anello di fermo (250)	Stop ring (250)	Bague d'arrêt (250)	Haltering (250)	Anillo de retención (250)	
	5	1615 35501	2	Anello di fermo (400)	Stop ring (400)	Bague d'arrêt (400)	Haltering (400)	Anillo de retención (400)	
	5	66N0 21257	2	Anello di fermo (450)	Stop ring (450)	Bague d'arrêt (450)	Haltering (450)	Anillo de retención (450)	
<b>A£</b>	5	8000 A3378	2	Anello di fermo (450)	Stop ring (450)	Bague d'arrêt (450)	Haltering (450)	Anillo de retención (450)	
<b>E</b>	6	8000 99747	1	Kit segmenti (250)	Circlip kit (250)	Kit segment (250)	Kolbenring kit (250)	Kit segmento (250)	
<b>A&amp;</b>	6	8000 A0607	1	Kit segmenti (250)	Circlip kit (250)	Kit segment (250)	Kolbenring kit (250)	Kit segmento (250)	
	6	8000 98116	1	Kit segmenti (400)	Circlip kit (400)	Kit segment (400)	Kolbenring kit (400)	Kit segmento (400)	
	6	8000 A0009	1	Kit segmenti (450)	Circlip kit (450)	Kit segment (450)	Kolbenring kit (450)	Kit segmento (450)	
<b>A£</b>	6	8000 A0855	1	Kit segmenti (450)	Circlip kit (450)	Kit segment (450)	Kolbenring kit (450)	Kit segmento (450)	
	7	8S00 67545	1	Vite scarico acqua	Coolant draining screw	Vis	Schraube	Tornillo	
	8	8A00 15960	1	Rosetta	Washer	Rondelle	Scheibe	Arandela	
	9	8A00 99805	1	Guarnizione (1,0 mm) (TC 250)	Gasket (1,0 mm) (TC 250)	Garnitue (1,0 mm) (TC 250)	Dichtung (1,0 mm) (TC 250)	Junta (1,0 mm) (TC 250)	

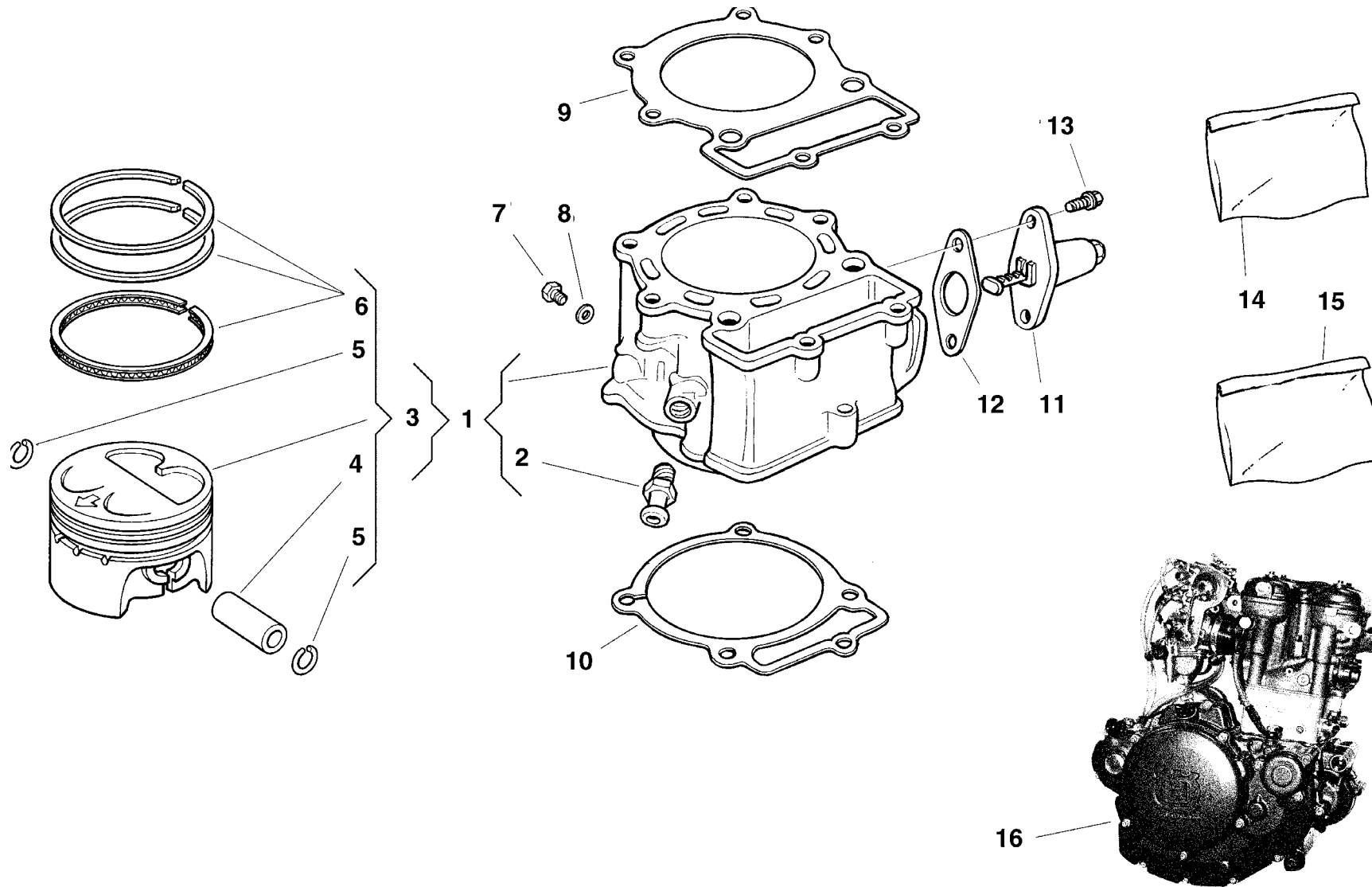





**TC-TE 250- 450,  
SM 400R-450R/ 2004**

TAVOLA  
DRAWING  
TABLE  
BILD  
TABLA

**3**

**CILINDRO, PISTONE - CYLINDER, PISTON  
CYLINDRE, PISTON-ZYLINDER, KOLBEN  
CILINDRO, PISTON**

Note Notes Notes Marke Notas	Pos. No. N. Index Pos.	N. Cod. Code No. Nr. Code Code Nr N. Cod.	Q.tà Q.ty Q.te M.ge C.ad	DENOMINAZIONE	NAME	DESIGNATION	BESHREIBUNG	DENOMINACION	Validità Validity Validité Gültig Validez
<b>R</b>	9	8A00 99805	1	Guarnizione (1,0 mm) (TE 250)	Gasket (1,0 mm) (TE 250)	Garnitue (1,0 mm) (TE 250)	Dichtung (1,0 mm) (TE 250)	Junta (1,0 mm) (TE 250)	
	9	8000 99805	1	Guarnizione (1,1 mm) (TE 250)	Gasket (1,1 mm) (TE 250)	Garnitue (1,1 mm) (TE 250)	Dichtung (1,1 mm) (TE 250)	Junta (1,1 mm) (TE 250)	
<b>R</b>	9	8B00 99805	1	Guarnizione (1,2 mm) (TE 250)	Gasket (1,2 mm) (TE 250)	Garnitue (1,2 mm) (TE 250)	Dichtung (1,2 mm) (TE 250)	Junta (1,2 mm) (TE 250)	
	9	8D00 99840	1	Guarnizione (1,0 mm) (400)	Gasket (1,0 mm) (400)	Garnitue (1,0 mm) (400)	Dichtung (1,0 mm) (400)	Junta (1,0 mm) (400)	
<b>S</b>	9	8A00 99840	1	Guarnizione (1,1 mm) (400)	Gasket (1,1 mm) (400)	Garnitue (1,1 mm) (400)	Dichtung (1,1 mm) (400)	Junta (1,1 mm) (400)	
	9	8G00 99840	1	Guarnizione (1,2 mm) (400)	Gasket (1,2 mm) (400)	Garnitue (1,2 mm) (400)	Dichtung (1,2 mm) (400)	Junta (1,2 mm) (400)	
	9	8E00 99840	1	Guarnizione (1,0 mm) (450)	Gasket (1,0 mm) (450)	Garnitue (1,0 mm) (450)	Dichtung (1,0 mm) (450)	Junta (1,0 mm) (450)	
	9	8B00 99840	1	Guarnizione (1,1 mm) (450)	Gasket (1,1 mm) (450)	Garnitue (1,1 mm) (450)	Dichtung (1,1 mm) (450)	Junta (1,1 mm) (450)	
	9	8H00 99840	1	Guarnizione (1,2 mm) (450)	Gasket (1,2 mm) (450)	Garnitue (1,2 mm) (450)	Dichtung (1,2 mm) (450)	Junta (1,2 mm) (450)	
	10	8000 99841	1	Guarnizione	Gasket	Garnitue	Dichtung	Junta	
	11	8000 67744	1	Tenditore completo	Complete tensioner	Tendeur complet	Zylinderspanner	Tensor completo	
	12	1615 35801	1	Guarnizione	Gasket	Garnitue	Dichtung	Junta	
	13	8000 62727	2	Vite	Screw	Vis	Schraube	Tornillo	
<b>R</b>	14	8000 99922	1	Gruppo guarn. motore (TE 250)	Gasket set (TE 250)	Groupe garnitures (TE 250)	Dichtungssatz (TE 250)	Grupo juntas (TE 250)	
<b>R</b>	14	8000 A2932	1	Gruppo guarn. motore (TC 250)	Gasket set (TC 250)	Groupe garnitures (TC 250)	Dichtungssatz (TC 250)	Grupo juntas (TC 250)	
<b>R</b>	14	8000 A0005	1	Gruppo guarn. motore (400)	Gasket set (400)	Groupe garnitures (400)	Dichtungssatz (400)	Grupo juntas (400)	
<b>R</b>	14	8000 A1315	1	Gruppo guarn. motore (TE 450)	Gasket set (TE 450)	Groupe garnitures (TE 450)	Dichtungssatz (TE 450)	Grupo juntas (TE 450)	
<b>R</b>	14	8000 A2771	1	Gruppo guarn. motore (TC 450)	Gasket set (TC 450)	Groupe garnitures (TC 450)	Dichtungssatz (TC 450)	Grupo juntas (TC 450)	
<b>R</b>	15	8000 99923	1	Gruppo anelli di tenuta motore	Engine seal ring set	Groupe bague moteur	Dichtungsringgruppe Motor	Grupo anillos	
	16	8000 A0045	1	Assieme motore (TE 250)	Engine assy (TE 250)	Moteur complet (TE 250)	Motor kpl. (TE 250)	Motor compl. (TE 250)	
	16	8000 A2857	1	Assieme motore (TC 250)	Engine assy (TC 250)	Moteur complet (TC 250)	Motor kpl. (TC 250)	Motor compl. (TC 250)	
	16	8000 A3087	1	Assieme motore (SMR 400)	Engine assy (SMR 400)	Moteur complet (SMR 400)	Motor kpl. (SMR 400)	Motor compl. (SMR 400)	
	16	8000 A1313	1	Assieme motore (TE-SMR 450)	Engine assy (TE-SMR 450)	Moteur complet (TE-SMR 450)	Motor kpl. (TE-SMR 450)	Motor compl. (TE-SMR 450)	
	16	8000 A2866	1	Assieme motore (TC 450)	Engine assy (TC 450)	Moteur complet (TC 450)	Motor kpl. (TC 450)	Motor compl. (TC 450)	
<b>&amp;</b>				MONTARE CON PISTONE	ASSEMBLE WITH PISTON	MONTERAVEC PISTON	EINBAU MIT KOLBEN	MONTAR CON PISTON	
				8000 A0604	8000 A0604	8000 A0604	8000 A0604	8000 A0604	
<b>£</b>				MONTARE CON PISTONE	ASSEMBLE WITH PISTON	MONTERAVEC PISTON	EINBAU MIT KOLBEN	MONTAR CON PISTON	
				8000 A0852	8000 A0852	8000 A0852	8000 A0852	8000 A0852	

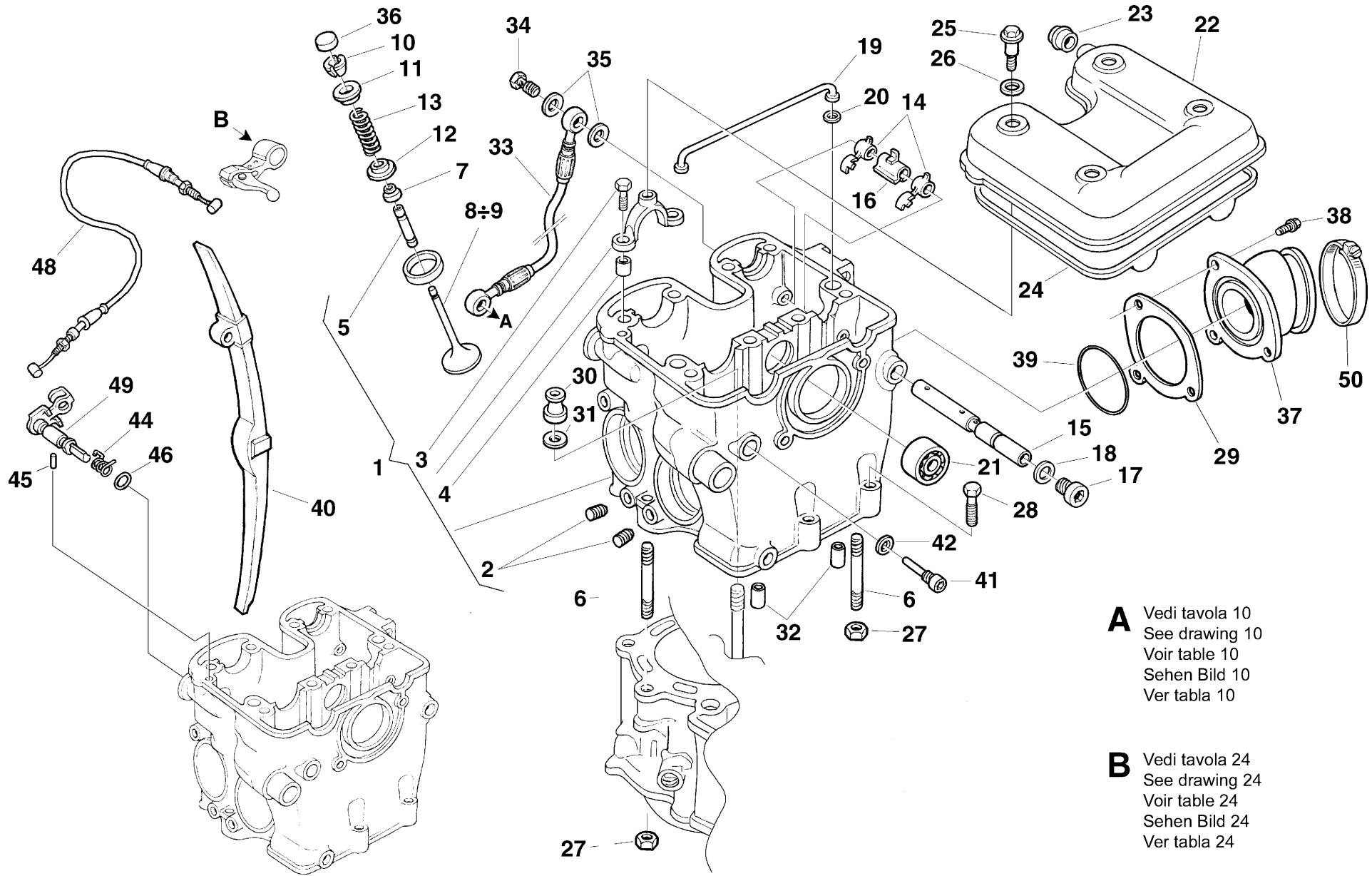

**A** Vedi tavola 10  
See drawing 10  
Voir table 10  
Sehen Bild 10  
Ver tabla 10

**B** Vedi tavola 24  
See drawing 24  
Voir table 24  
Sehen Bild 24  
Ver tabla 24



**TC-TE 250- 450,  
SM 400R-450R/ 2004**

TAVOLA  
DRAWING  
TABLE  
BILD  
TABLA

**4**

**TESTA CILINDRO - CYLINDER HEAD  
CULASSE - ZYLINDERKOPF  
CULATA**

Note Notes Notas	Pos. No. N. Index Pos.	N. Cod. Code No. Nr. Code Code Nr N. Cod.	Q.tà Q.ty Q.te M.ge C.ad	DENOMINAZIONE	NAME	DESIGNATION	BESCHREIBUNG	DENOMINACION	Validità Validity Validité Gültig Validez
	1	8000 A2863	1	Testa completa (250)	Cylinder head assy. (250)	Culasse complete (250)	Zylinderkopf Kpl. (250)	Culata completa (250)	
	1	8000 99826	1	Testa completa (400-450)	Cylinder head assy. (400-450)	Culasse complete (400-450)	Zylinderkopf Kpl. (400-450)	Culata completa (400-450)	
	2	8000 49792	4	Heli-coil	Heli-coil	Heli-coil	Heli-coil	Heli-coil	
	3	8A00 85071	8	Vite (M6X25 mm)	Screw (M6X25 mm)	Vis (M6X25 mm)	Schraube (M6X25 mm)	Tornillo (M6X25 mm)	
	4	1617 95501	8	Bussola	Bushing	Douille	Buchse	Manguito	
	5	8000 A0567	4	Guidavalvola (250) Ø10,5	Valve guide (250) Ø10,5	Guide-soupape (250) Ø10,5	Ventilführung (250) Ø10,5	Guía-válvula (250) Ø10,5	
	5	8000 A1041	4	Guidavalvola Ø10,5 (400-450)	Valve guide Ø10,5 (400-450)	Guide-soupape Ø10,5 (400-450)	Ventilführung Ø10,5 (400-450)	Guía-válvula Ø10,5 (400-450)	
	6	8000 74836	2	Prigioniero (M8X51 mm)	Stud bolt (M8X51 mm)	Prisonnier (M8X51 mm)	Stiftschraube (M8X51 mm)	Prisionero (M8X51 mm)	
	7	8000 98167	4	Anello di tenuta	Seal ring	Bague d'étanchéité	Dichtungsring	Anillo de retención	
	8	8000 A2731	2	Valvola aspirazione (250)	Inlet valve (250)	Soupape admission (250)	Einlass-Ventil (250)	Válvula aspiración (250)	
	8	8000 A1942	2	Valvola aspirazione (400-450)	Inlet valve (400-450)	Soupape admission (400-450)	Einlass-Ventil (400-450)	Válvula aspiración (400-450)	
	9	8000 A0341	2	Valvola scarico (250)	Exhaust valve (250)	Soupape d'échapp. (250)	Auslass-Ventil (250)	Válvula de escape (250)	
	9	8000 A0342	2	Valvola scarico (400-450)	Exhaust valve (400-450)	Soupape d'échapp. (400-450)	Auslass-Ventil (400-450)	Válvula de escape (400-450)	
	10	8000 92433	8	Semicono	Half cone	Demi-cône	Halb Kegel	Semi-cono	
	11	8000 91577	4	Scodellino	Cup	Cuvette	Teller	Cubeta	
	12	8000 91578	4	Piattello	Cup	Cuvette	Teller	Cubeta	
	13	8000 91579	4	Molla (250)	Spring (250)	Ressort (250)	Feder (250)	Resorte (250)	
	13	8000 A0568	4	Molla (400-450)	Spring (400-450)	Ressort (400-450)	Feder (400-450)	Resorte (400-450)	
	14	8000 91568	4	Bilanciere	Rocker-arm assy	Culbuteur	Kipphebel	Balancín	
	15	8000 91580	2	Perno (250)	Pin (250)	Pivot (250)	Bolzen (250)	Perno (250)	
	15	8000 99833	2	Perno (400-450)	Pin (400-450)	Pivot (400-450)	Bolzen (400-450)	Perno (400-450)	
	16	8000 91582	2	Distanziale a molla (250)	Spacer (250)	Entretoise (250)	Distanzstück (250)	Separador (250)	
	16	8A00 91582	1	Distanziale a molla (L=25,8 mm) (400-450)	Spacer (L=25,8 mm) (400-450)	Entretoise (L=25,8 mm) (400-450)	Distanzstück (L=25,8 mm) (400-450)	Separador (L=25,8 mm) (400-450)	
	16	8B00 91582	1	Distanziale a molla (L=27,8 mm) (400-450)	Spacer (L=27,8 mm) (400-450)	Entretoise (L=27,8 mm) (400-450)	Distanzstück (L=27,8 mm) (400-450)	Separador (L=27,8 mm) (400-450)	
	17	8000 99711	2	Tappo	Plug	Bouchon	Verschluss	Tapón	
	18	8000 47763	2	Rosetta piana	Washer	Rondelle	Scheibe	Arandela	
	19	8000 91583	1	Tubetto olio (250)	Oil pipe (250)	Tuyau (250)	Rohr (250)	Tubo (250)	
	19	8000 99834	1	Tubetto olio (400-450)	Oil pipe (400-450)	Tuyau (400-450)	Rohr (400-450)	Tubo (400-450)	
	20	8000 91584	2	Anello OR	O-Ring	Bague OR	O-Ring	Anillo OR	
	21	8000 34317	1	Cuscinetto (Ø12xØ28x8 mm)	Bearing (Ø12xØ28x8 mm)	Roulement (Ø12xØ28x8 mm)	Lager (Ø12xØ28x8 mm)	Cojinete (Ø12xØ28x8 mm)	

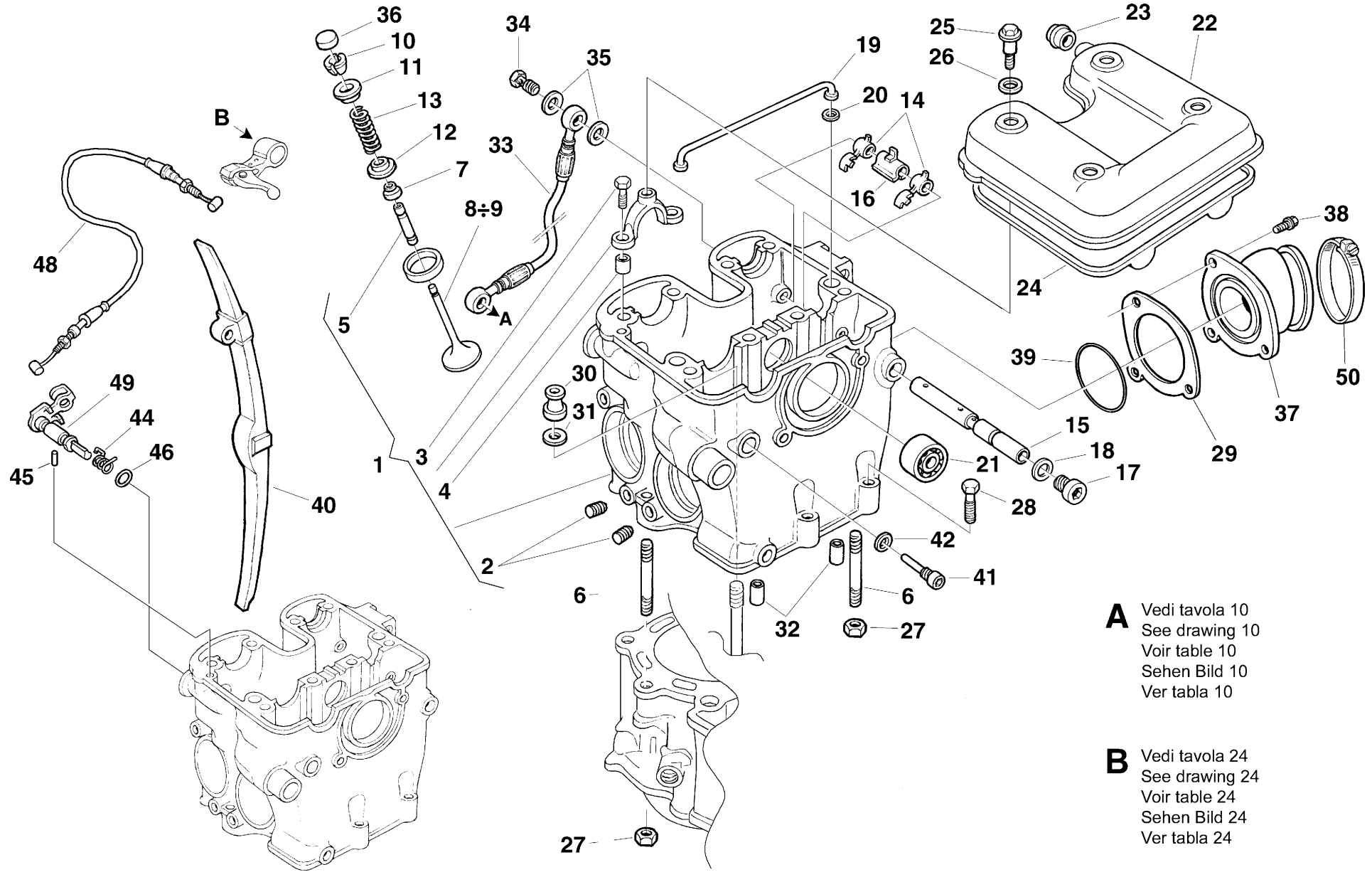

**A** Vedi tavola 10  
See drawing 10  
Voir table 10  
Sehen Bild 10  
Ver tabla 10

**B** Vedi tavola 24  
See drawing 24  
Voir table 24  
Sehen Bild 24  
Ver tabla 24



TC-TE 250- 450,  
SM 400R-450R/ 2004

TAVOLA  
DRAWING  
TABLE  
BILD  
TABLA

4

TESTA CILINDRO - CYLINDER HEAD  
CULASSE - ZYLINDERKOPF  
CULATA

Note Notes Notas	Pos. No. Index Pos.	N. Cod. Code No. Nr. Code Code Nr N. Cod.	Q.tà Q.ty Q.te M.ge C.ad	DENOMINAZIONE	NAME	DESIGNATION	BESHREIBUNG	DENOMINACION	Validità Validity Validité Gültig Validez
	22	80A0 91548	1	Coperchio testa (250)	Cylinder head cover (250)	Couvercle culasse (250)	Zylinderkopf Deckel (250)	Tapa Culata (250)	
	22	80A0 99836	1	Coperchio testa (400-450)	Cylinder head cover (400-450)	Couvercle culasse (400-450)	Zylinderkopf Deckel (400-450)	Tapa Culata (400-450)	
	23	8000 91586	1	Raccordo sfiato	Union	Raccord	Anschluss	Empalme	
	24	8000 91566	1	Guarnizione (250)	Gasket (250)	Garnitue (250)	Dichtung (250)	Junta (250)	
	24	8000 99837	1	Guarnizione (400-450)	Gasket (400-450)	Garnitue (400-450)	Dichtung (400-450)	Junta (400-450)	
	25	8000 91587	4	Vite	Screw	Vis	Schraube	Tornillo	
	26	8000 91588	4	Rosetta di tenuta	Sealing washer	Rondelle	Scheibe	Arandela	
	27	8000 54700	2	Dado	Nut	Ecrou	Mutter	Tuerca	
	28	8000 62730	3	Vite (M6X30 mm)	Screw (M6X30 mm)	Vis (M6X30 mm)	Schraube (M6X30 mm)	Tornillo (M6X30 mm)	
V	29	8000 A0989	1	Flangia (TE-SM 450)	Flange (TE-SM 450)	Bride (TE-SM 450)	Flansch (TE-SM 450)	Brida (TE-SM 450)	
	30	8000 91589	4	Dado	Nut	Ecrou	Mutter	Tuerca	
	31	8000 23374	4	Rosetta piana	Washer	Rondelle	Scheibe	Arandela	
	32	8000 47708	4	Bussola di riferimento	Bushing	Douille	Buchse	Manguito	
	33	8000 A0232	1	Tubo olio (250)	Oil pipe (250)	Tuyau (250)	Rohr (250)	Tubo (250)	
	33	8A00 A0232	1	Tubo olio (400-450)	Oil pipe (400-450)	Tuyau (400-450)	Rohr (400-450)	Tubo (400-450)	
	34	8000 A0574	2	Vite	Screw	Vis	Schraube	Tornillo	
	35	8000 A0575	4	Rosetta di tenuta	Sealing washer	Rondelle	Scheibe	Arandela	
	36	8000 A2141	4	Pastiglia (1,60 mm)	Pad (1,60 mm)	Plaquette (1,60 mm)	Belag (1,60 mm)	Pastilla (1,60 mm)	
	36	8A00 A2141	4	Pastiglia (1,65 mm)	Pad (1,65 mm)	Plaquette (1,65 mm)	Belag (1,65 mm)	Pastilla (1,65 mm)	
	36	8B00 A2141	4	Pastiglia (1,70 mm)	Pad (1,70 mm)	Plaquette (1,70 mm)	Belag (1,70 mm)	Pastilla (1,70 mm)	
	36	8C00 A2141	4	Pastiglia (1,75 mm)	Pad (1,75 mm)	Plaquette (1,75 mm)	Belag (1,75 mm)	Pastilla (1,75 mm)	
	36	8D00 A2141	4	Pastiglia (1,80 mm)	Pad (1,80 mm)	Plaquette (1,80 mm)	Belag (1,80 mm)	Pastilla (1,80 mm)	
	36	8E00 A2141	4	Pastiglia (1,85 mm)	Pad (1,85 mm)	Plaquette (1,85 mm)	Belag (1,85 mm)	Pastilla (1,85 mm)	
	36	8F00 A2141	4	Pastiglia (1,90 mm)	Pad (1,90 mm)	Plaquette (1,90 mm)	Belag (1,90 mm)	Pastilla (1,90 mm)	
	36	8G00 A2141	4	Pastiglia (1,95 mm)	Pad (1,95 mm)	Plaquette (1,95 mm)	Belag (1,95 mm)	Pastilla (1,95 mm)	
	36	8H00 A2141	4	Pastiglia (2,00 mm)	Pad (2,00 mm)	Plaquette (2,00 mm)	Belag (2,00 mm)	Pastilla (2,00 mm)	
	36	8J00 A2141	4	Pastiglia (2,05 mm)	Pad (2,05 mm)	Plaquette (2,05 mm)	Belag (2,05 mm)	Pastilla (2,05 mm)	
	36	8K00 A2141	4	Pastiglia (2,10 mm)	Pad (2,10 mm)	Plaquette (2,10 mm)	Belag (2,10 mm)	Pastilla (2,10 mm)	
	36	8L00 A2141	4	Pastiglia (2,15 mm)	Pad (2,15 mm)	Plaquette (2,15 mm)	Belag (2,15 mm)	Pastilla (2,15 mm)	
	36	8M00 A2141	4	Pastiglia (2,20 mm)	Pad (2,20 mm)	Plaquette (2,20 mm)	Belag (2,20 mm)	Pastilla (2,20 mm)	
	36	8N00 A2141	4	Pastiglia (2,25 mm)	Pad (2,25 mm)	Plaquette (2,25 mm)	Belag (2,25 mm)	Pastilla (2,25 mm)	
	36	8P00 A2141	4	Pastiglia (2,30 mm)	Pad (2,30 mm)	Plaquette (2,30 mm)	Belag (2,30 mm)	Pastilla (2,30 mm)	



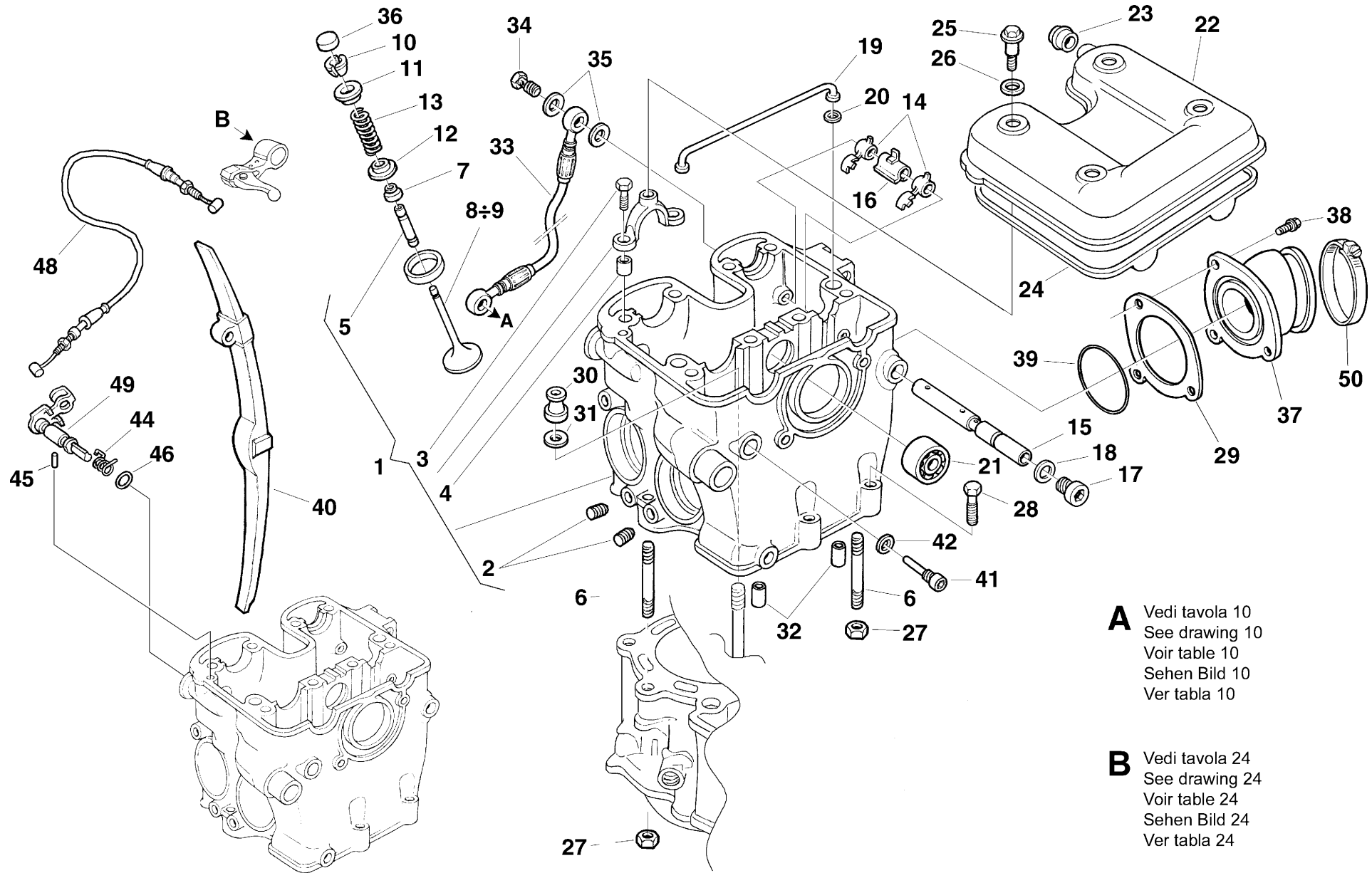

**A** Vedi tavola 10  
See drawing 10  
Voir table 10  
Sehen Bild 10  
Ver tabla 10

**B** Vedi tavola 24  
See drawing 24  
Voir table 24  
Sehen Bild 24  
Ver tabla 24



**TC-TE 250- 450,  
SM 400R-450R/ 2004**

TAVOLA  
DRAWING  
TABLE  
BILD  
TABLA

**4**

**TESTA CILINDRO - CYLINDER HEAD  
CULASSE - ZYLINDERKOPF  
CULATA**

Note Notes Marke Notas	Pos. No. Index Pos.	N. Cod. Code No. Nr. Code Code Nr N. Cod.	Q.tà Q.ty M.ge C.ad	DENOMINAZIONE	NAME	DESIGNATION	BESHREIBUNG	DENOMINACION	Validità Validity Validité Gültig Validez
	36	8R00 A2141	4	Pastiglia (2,35 mm)	Pad (2,35 mm)	Plaquette (2,35 mm)	Belag (2,35 mm)	Pastilla (2,35 mm)	
	36	8S00 A2141	4	Pastiglia (2,40 mm)	Pad (2,40 mm)	Plaquette (2,40 mm)	Belag (2,40 mm)	Pastilla (2,40 mm)	
	36	8T00 A2141	4	Pastiglia (2,45 mm)	Pad (2,45 mm)	Plaquette (2,45 mm)	Belag (2,45 mm)	Pastilla (2,45 mm)	
	36	8U00 A2141	4	Pastiglia (2,50 mm)	Pad (2,50 mm)	Plaquette (2,50 mm)	Belag (2,50 mm)	Pastilla (2,50 mm)	
	36	8V00 A2141	4	Pastiglia (2,55 mm)	Pad (2,55 mm)	Plaquette (2,55 mm)	Belag (2,55 mm)	Pastilla (2,55 mm)	
	36	8W00 A2141	4	Pastiglia (2,60 mm)	Pad (2,60 mm)	Plaquette (2,60 mm)	Belag (2,60 mm)	Pastilla (2,60 mm)	
	37	8000 99664	1	Raccordo carburatore (TE 250)	Union (TE 250)	Raccord (TE 250)	Anschluss (TE 250)	Empalme (TE 250)	
	37	8000 A2121	1	Raccordo carburatore (TC 250)	Union (TC 250)	Raccord (TC 250)	Anschluss (TC 250)	Empalme (TC 250)	
	37	8000 99887	1	Raccordo (400)	Union (400)	Raccord (400)	Anschluss (400)	Empalme (400)	
	37	8000 A0031	1	Raccordo (450)	Union (450)	Raccord (450)	Anschluss (450)	Empalme (450)	
	38	8000 62728	3	Vite (M6x20 mm)	Screw (M6x20 mm)	Vis (M6x20 mm)	Schraube (M6x20 mm)	Tornillo (M6x20 mm)	
	39	8000 19965	1	Anello OR	O-Ring	Bague OR	O-Ring	Anillo OR	
	40	8000 91553	1	Pattino catena	Chain slider	Glissière de chaine	Gleitbahn	Platode cadena	
	41	1615 35902	1	Vite	Screw	Vis	Schraube	Tornillo	
	42	8000 45194	1	Rosetta di tenuta	Sealing washer	Rondelle	Scheibe	Arandela	
	44	8000 99687	1	Molla alzavalvole	Spring	Ressort	Feder	Resorte	
	45	8000 44298	1	Rullino	Roller	Aiguille	Rolle	Rodillo	
	46	8000 23107	1	Anello OR	O-Ring	Bague OR	O-Ring	Anillo OR	
<b>YA</b>	48	8000 A0303	1	Trasmissione alzavalvole	Wire	Fil	Kabel	Transmision	
	48	8A00 A0303	1	Trasmissione alzavalvole	Wire	Fil	Kabel	Transmision	
	49	8000 99684	1	Assieme alzavalvole	Valve lifter assy.	Ensemble transmission dispositif de décompression	Decompressionvorrichtung- kabel Kpl.	Grupo transmisiòn dispositivo decompression	
	50	8G00 99475	1	Fascetta	Clamp	Collier	Schelle	Abrazadera	
<b>V</b>				Versione 34 cv	Version 34 cv	Version 34 cv	Version 34 CV	Version 34 cv	

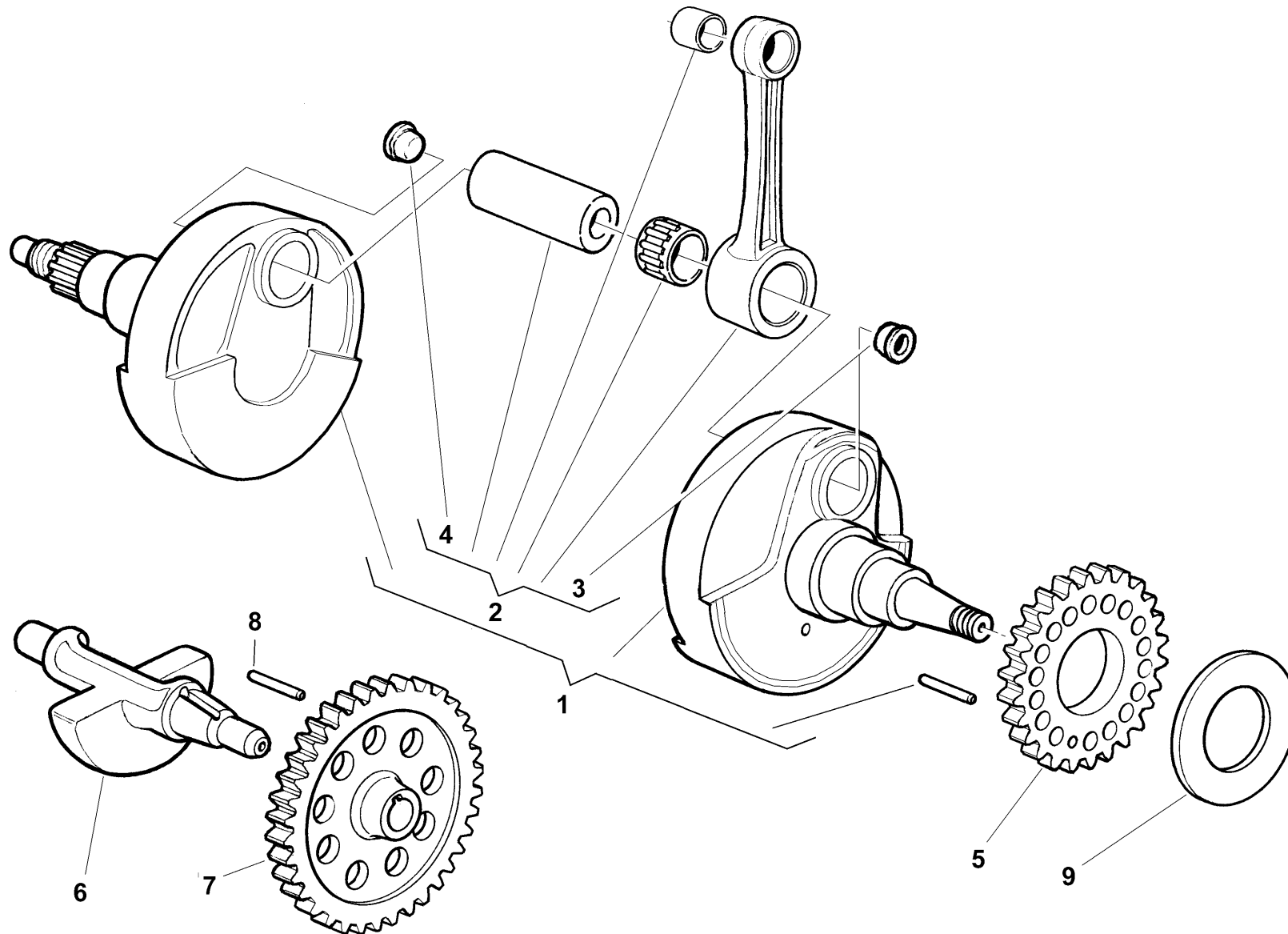



**TC-TE 250- 450,  
SM 400R-450R/ 2004**

TAVOLA  
DRAWING  
TABLE  
BILD  
TABLA

**5**

**MANOVELLISMO - CRANKSHAFT  
VILEBREQUIN - KURBELWELLE  
CIGÜEÑAL**

Note Notes Markes Notas	Pos. No. N. Index Pos.	N. Cod. Code No. Nr. Code Code Nr N. Cod.	Q.tà Q.ty Q.té M.ge C.ad	DENOMINAZIONE	NAME	DESIGNATION	BESHREIBUNG	DENOMINACION	Validità Validity Validité Gültig Validez
<b>EN</b>	1	8000 99938	1	Albero motore compl. (250)	Crankshaft assy (250)	Vilebrequin compl. (250)	Kurbewelle kpl. (250)	Cigüeñal compl. (250)	
£	1	8000 A3455	1	Albero motore compl. (250)	Crankshaft assy (250)	Vilebrequin compl. (250)	Kurbewelle kpl. (250)	Cigüeñal compl. (250)	
<b>EN</b>	1	8000 99983	1	Alb. motore compl. (400-450)	Crankshaft assy (400-450)	Vilebrequin compl. (400-450)	Kurbewelle kpl. (400-450)	Cigüeñal compl. (400-450)	
&	1	8000 A3463	1	Alb. motore compl. (400-450)	Crankshaft assy (400-450)	Vilebrequin compl. (400-450)	Kurbewelle kpl. (400-450)	Cigüeñal compl. (400-450)	
	2	8000 99939	1	Biella completa (250)	Conrod assy. (250)	Bielle compl. (250)	Pleuelstange kpl. (250)	Biela motor completa (250)	
	2	8000 99984	1	Biella completa (400-450)	Conrod assy. (400-450)	Bielle compl. (400-450)	Pleuelstange kpl. (400-450)	Biela motor compl. (400-450)	
	3	8000 57196	1	Tappo	Plug	Bouchon	Verschluss	Tapòn	
	4	8000 57196	1	Tappo	Plug	Bouchon	Verschluss	Tapòn	
<b>Y</b>	5	8000 99915	1	Ingranaggio (Z=30)	Gear (Z=30)	Engranage (Z=30)	Zahnrad (Z=30)	Engranaje (Z=30)	
<b>Y</b>	6	8A00 99913	1	Contralbero (250)	Layshaft (250)	Arbre de bal. (250)	Worgelegewelle (250)	Contra eje (250)	
<b>Y</b>	6	8000 99913	1	Contralbero (400-450)	Layshaft (400-450)	Arbre de bal. (400-450)	Worgelegewelle (400-450)	Contra eje (400-450)	
<b>Y</b>	7	8000 99916	1	Ingranaggio (Z=30)	Gear (Z=30)	Engranage (Z=30)	Zahnrad (Z=30)	Engranaje (Z=30)	
<b>Y</b>	8	8A00 47773	1	Rullino	Roller	Aiguille	Rolle	Rodillo	
	9	8A00 28183	1	Rosetta di rasamento (0,3 mm)	Washer (0,3 mm)	Rondelle (0,3 mm)	Scheibe (0,3 mm)	Arandela (0,3 mm)	
	9	8C00 28183	1	Rosetta di rasamento (0,5 mm)	Washer (0,5 mm)	Rondelle (0,5 mm)	Scheibe (0,5 mm)	Arandela (0,5 mm)	
	9	8D00 28183	1	Rosetta di rasamento (0,6 mm)	Washer (0,6 mm)	Rondelle (0,6 mm)	Scheibe (0,6 mm)	Arandela (0,6 mm)	
	9	8F00 28183	1	Rosetta di rasamento (0,8 mm)	Washer (0,8 mm)	Rondelle (0,8 mm)	Scheibe (0,8 mm)	Arandela (0,8 mm)	
	9	8H00 28183	1	Rosetta di rasamento (1,0 mm)	Washer (1,0 mm)	Rondelle (1,0 mm)	Scheibe (1,0 mm)	Arandela (1,0 mm)	
£				Fornire in accoppiamento con 8000A3458 Tav.6 pos.17	Supply unitedly to part 8000A3458 Draw.6 no.17	Fournir ensemble à part 8000A3458 Tab.6 N.17	Wird paaren mit Teile 8000A3458 Bild 6 Index 17	Equipar acoplado al part. 8000A3458 Tab.6 pos.17	
&				Fornire in accoppiamento con 8000A3466 Tav.6 pos.17	Supply unitedly to part 8000A3466 Draw.6 no.17	Fournir ensemble à part 8000A3466 Tab.6 N.17	Wird paaren mit Teile 8000A3466 Bild 6 Index 17	Equipar acoplado al part. 8000A3466 Tab.6 pos.17	

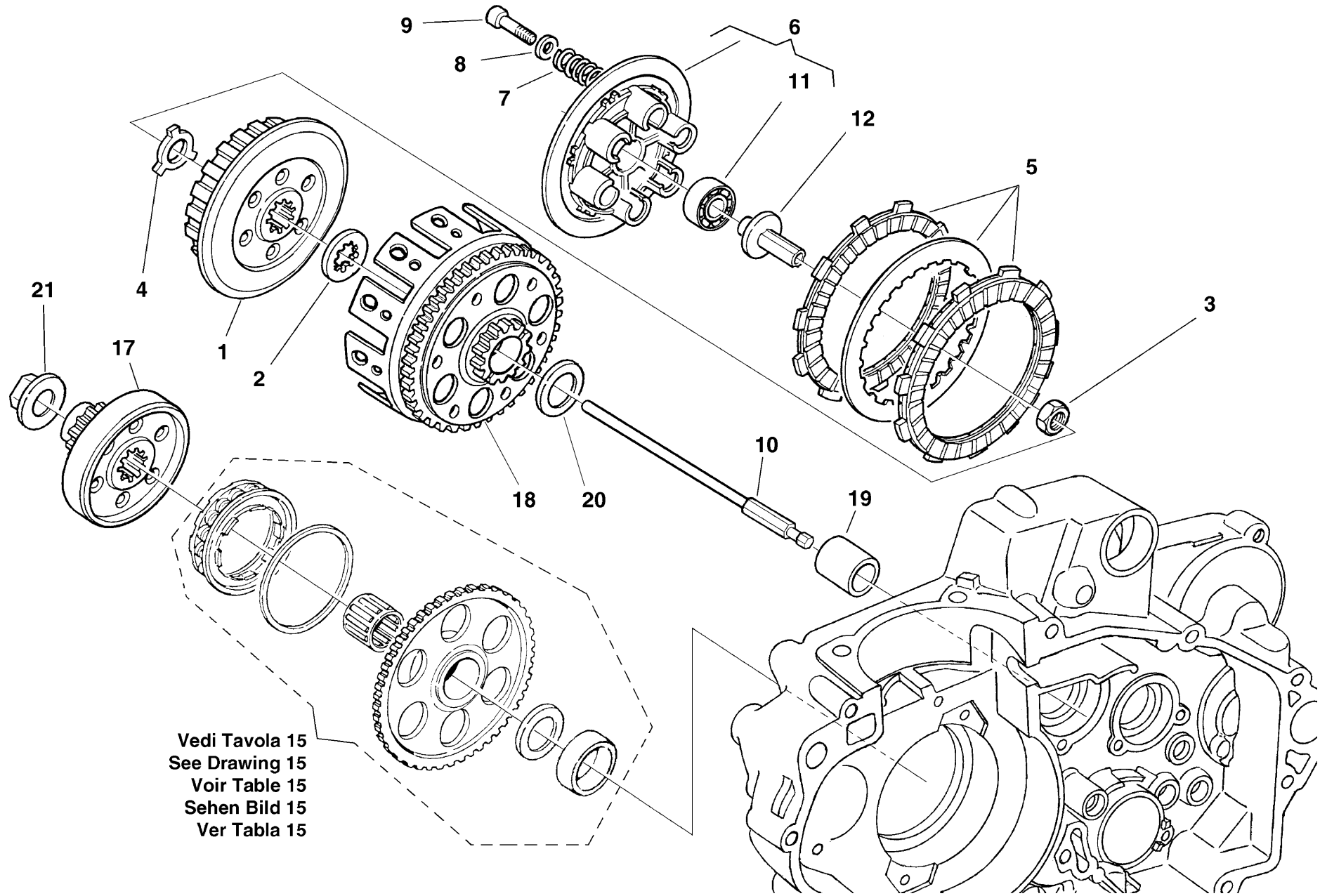



Note Notes Marka Notas	Pos. No. N. Index	N. Cod. Code No. Nr. Code Code Nr N. Cod.	Q.tà Q.ty M.ge C.ad	DENOMINAZIONE	NAME	DESIGNATION	BESHREIBUNG	DENOMINACION	Validità Validity Validité Gültig Validez
	1	8C00 96746	1	Mozzo frizione (250)	Hub (250)	Moyeau (250)	Radnabe (250)	Cubo (250)	
	1	8D00 96746	1	Mozzo frizione (400-450)	Hub (400-450)	Moyeau (400-450)	Radnabe (400-450)	Cubo (400-450)	
	2	8A00 38350	1	Rosetta	Washer	Rondelle	Scheibe	Arandela	
	3	8000 36856	1	Dado	Nut	Ecrou	Mutter	Tuerca	
	4	8000 36857	1	Rosetta	Washer	Rondelle	Scheibe	Arandela	
	5	8000 A0611	1	Ass. gr. dischi frizione (250)	Clutch group assy (250)	Gr. embrayage compl. (250)	Kupplungsgruppe Kpl (250)	Gr. embrague compl. (250)	
	5	8A00 A0611	1	Ass. gr. dischi frizione (400-450)	Clutch group assy (400-450)	Gr. embrayage compl. (400-450)	Kupplungsgruppe Kpl (400-450)	Gr. embrague compl. (400-450)	
	6	8000 81508	1	Piastra spingidisci	Plate	Plaque	Platte	Placa	
	7	8000 A0730	6	Molla frizione	Clutch spring	Ressort embrayage	Kupplungsfeder	Resorte embrague	
	8	8000 81519	6	Scodellino	Cup	Cuvette	Teller	Cubeta	
	9	60N1 02510	6	Vite	Screw	Vis	Schraube	Tornillo	
<b>WM</b>	10	8000 99953	1	Astina disinnesto	Control rod.	Coulisseau	Steuerstange	Varilla	D.m.
<b>E</b>	10	8000 99953	1	Astina disinnesto (250)	Control rod (250)	Coulisseau (250)	Steuerstange (250)	Varilla (250)	F.m.
	10	8000 A2654	1	Astina disinnesto (TC 250)	Control rod (TC 250)	Coulisseau (TC 250)	Steuerstange (TC 250)	Varilla (TC 250)	D.m.
<b>E</b>	10	8A00 99953	1	Astina disinnesto (400-450)	Control rod (400-450)	Coulisseau (400-450)	Steuerstange (400-450)	Varilla (400-450)	F.m.
	11	8000 34317	1	Cuscinetto (ø12xø28x8 mm)	Bearing (ø12xø28x8 mm)	Roulement (ø12xø28x8 mm)	Lager (ø12xø28x8 mm)	Cojinete (ø12xø28x8 mm)	
<b>E</b>	12	8000 A0882	1	Perno com. frizione	Pin	Pivot	Bolzen	Perno	F.m.
	12	8000 A0882	1	Perno com. frizione (250)	Pin (250)	Pivot (250)	Bolzen (250)	Perno (250)	D.m.
	12	8A00 A0882	1	Perno com. frizione (400-450)	Pin (400-450)	Pivot (400-450)	Bolzen (400-450)	Perno (400-450)	D.m.
<b>E</b>	17	8000 A0749	1	Ingr. conduttore (Z=24) (250)	Gear (Z=24) (250)	Engrangement (Z=24) (250)	Zahnrad (Z=24) (250)	Engranaje (Z=24) (250)	
<b>\$</b>	17	8000 A3458	1	Ingr. conduttore (Z=24) (250)	Gear (Z=24) (250)	Engrangement (Z=24) (250)	Zahnrad (Z=24) (250)	Engranaje (Z=24) (250)	
<b>E</b>	17	8000 99930	1	Ingr. condutt. (Z=27) (400-450)	Gear (Z=27) (400-450)	Engrangement (Z=27) (400-450)	Zahnrad (Z=27) (400-450)	Engranaje (Z=27) (400-450)	
<b>£</b>	17	8000 A3466	1	Ingr. condutt. (Z=27) (400-450)	Gear (Z=27) (400-450)	Engrangement (Z=27) (400-450)	Zahnrad (Z=27) (400-450)	Engranaje (Z=27) (400-450)	
	18	8000 A0751	1	Campana frizione compl. (250)	Clutch housing compl. (250)	Cage embrayage compl. (250)	Kupplungskorb kpl. (250)	Campana embrague compl. (250)	
	18	8A00 98574	1	Campana frizione completa (400-450)	Clutch housing compl. (400-450)	Cage embrayage compl. (400-450)	Kupplungskorb kpl. (400-450)	Campana embrague compl. (400-450)	
	19	1615 38801	1	Bussola	Bushing	Douille	Buchse	Manguito	
	20	8E00 30053	1	Rosetta	Washer	Rondelle	Scheibe	Arandela	
	21	8000 99933	1	Dado	Nut	Ecrou	Mutter	Tuerca	
<b>\$</b>				Fornire in accoppiamento con 8000A3455 Tav.5 pos.1	Supply unitedly to part 8000A3455 Draw.5 no.1	Fournir ensemble à part 8000A3455 Tab.5 N.1	Wird paaren mit Teile 8000A3455 Bild 5 Index 1	Equipar acoplado al part. 8000A3455 Tab.5 pos.1	
<b>£</b>				Fornire in accoppiamento con 8000A3463 Tav.5 pos.1	Supply unitedly to part 8000A3463 Draw.5 no.1	Fournir ensemble à part 8000A3463 Tab.5 N.1	Wird paaren mit Teile 8000A3463 Bild 5 Index 1	Equipar acoplado al part. 8000A3463 Tab.5 pos.1	

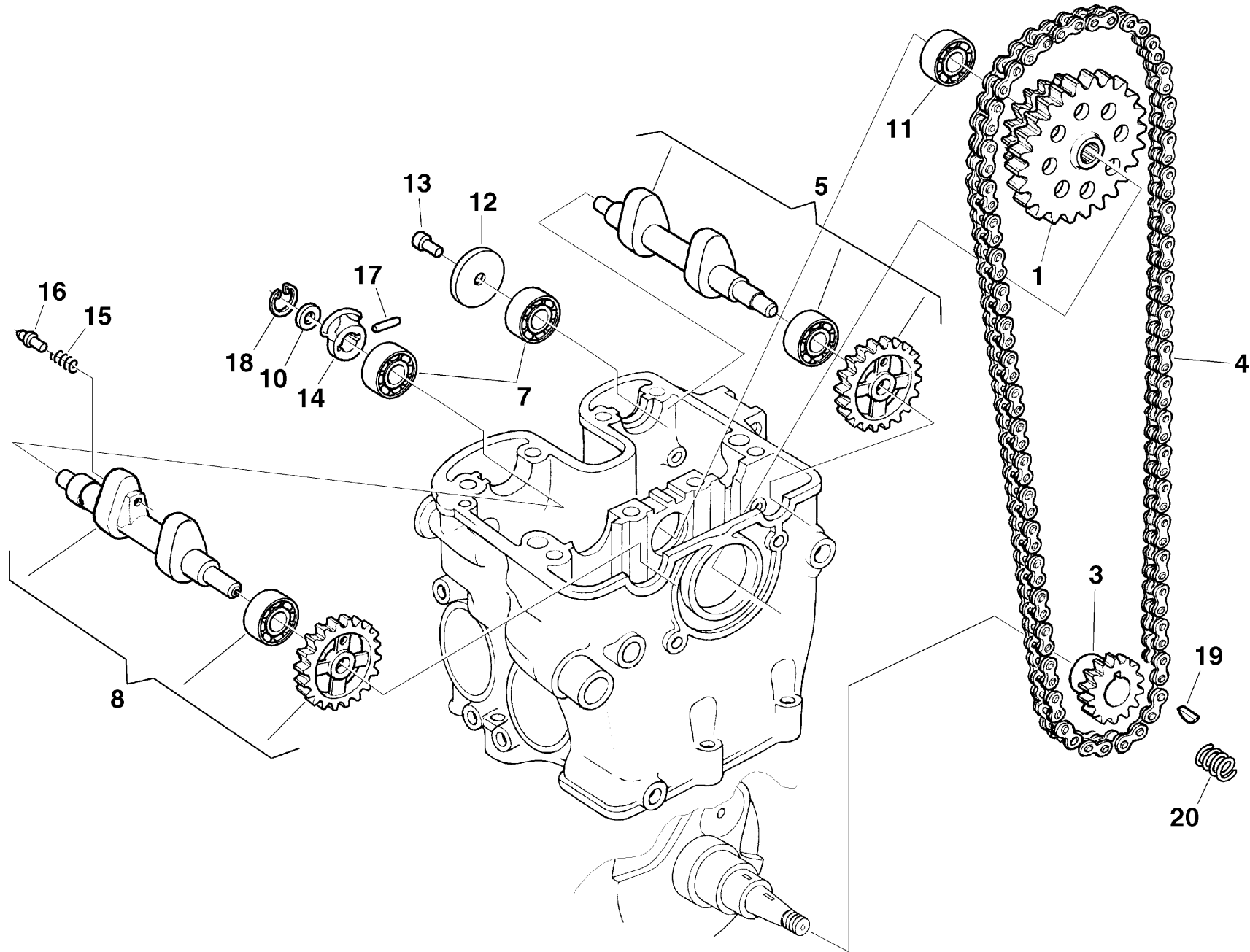



TC-TE 250- 450,  
SM 400R-450R/ 2004

TAVOLA  
DRAWING  
TABLE  
BILD  
TABLA

7

DISTRIBUZIONE - VALVE TIMING  
DISTRIBUTION - VENTILSTEUERUNG  
DISTRIBUCION

Note Notes Notas	Pos. No. N. Index Pos.	N. Cod. Code No. Nr. Code Code Nr N. Cod.	Q.tà Q.ty Q.te M.ge C.ad	DENOMINAZIONE	NAME	DESIGNATION	BESCHREIBUNG	DENOMINACION	Validità Validity Validité Gültig Validez
	1	8000 99689	1	Ingranaggio rinvio (Z=33/34) (250)	Gear (Z=33/34) (250)	Engrange (Z=33/34) (250)	Zahnrad (Z=33/34) (250)	Engranaje (Z=33/34) (250)	
	1	8000 99876	1	Ingranaggio rinvio (Z=36/34) (400-450)	Gear (Z=36/34) (400-450)	Engrange (Z=36/34) (400-450)	Zahnrad (Z=36/34) (400-450)	Engranaje (Z=36/34) (400-450)	
	2	8000 34317	2	Cuscinetto (ø12xø28x8 mm)	Bearing (ø12xø28x8 mm)	Roulement (ø12xø28x8 mm)	Lager (ø12xø28x8 mm)	Cojinete (ø12xø28x8 mm)	
	3	8C00 63811	1	Ingran. distribuzione (Z=17)	Gear (Z=17)	Engrange (Z=17)	Zahnrad (Z=17)	Engranaje (Z=17)	
	4	8F00 35794	1	Catena distribuzione (250) (88 maglie)	Chain (250) (88 link)	Chaîne (250) (88 maillon)	Kette (250) (88 Schake)	Cadena (250) (88 malla)	
	4	8C00 35794	1	Catena distribuzione (94 maglie) (400-450)	Chain (400-450) (94 link)	Chaîne (400-450) (94 maillon)	Kette (400-450) (94 Schake)	Cadena (400-450) (94 malla)	
	5	8000 99690	1	Albero a camme ASPIRAZIONE (TE 250)	Camshaft INTAKE (TE 250)	Arbre distribution ADMISSION (TE 250)	Nockenwelle ANSAUGSEITE (TE 250)	Eje distribución ASPIRACIÓN (TE 250)	
	5	8000 A3787	1	Albero a camme ASPIRAZIONE (TC 250)	Camshaft INTAKE (TC 250)	Arbre distribution ADMISSION (TC 250)	Nockenwelle ANSAUGSEITE (TC 250)	Eje distribución ASPIRACIÓN (TC 250)	
	5	8000 99877	1	Albero a camme ASPIRAZIONE (TE-SM400-450)	Camshaft INTAKE (TE-SM 400-450)	Arbre distribution ADMISSION (TE-SM 400-450)	Nockenwelle ANSAUGSEITE (TE-SM 400-450)	Eje distribución ASPIRACIÓN (TE-SM 400-450)	
	5	8000 A2765	1	Albero a camme ASPIRAZIONE (TC 450)	Camshaft INTAKE (TC 450)	Arbre distribution ADMISSION (TC 450)	Nockenwelle ANSAUGSEITE (TC 450)	Eje distribución ASPIRACIÓN (TC 450)	
	7	8000 34317	2	Cuscinetto (ø12xø28x8 mm)	Bearing (ø12xø28x8 mm)	Roulement (ø12xø28x8 mm)	Lager (ø12xø28x8 mm)	Cojinete (ø12xø28x8 mm)	
	8	8000 99694	1	Albero a camme SCARICO (250)	Camshaft EXHAUST (250)	Arbre distr. ECHAPPEMENT (250)	Nockenwelle AUSPUFFSEITE (250)	Eje distribución DESCARGA (250)	
	8	8000 99880	1	Albero a camme SCARICO (400-450)	Camshaft EXHAUST (400-450)	Arbre distr. ECHAPPEMENT (400-450)	Nockenwelle AUSPUFFSEITE (400-450)	Eje distribución DESCARGA (400-450)	
	10	8000 99702	1	Rosetta di rasamento	Washer	Rondelle	Scheibe	Arandela	
	11	8000 34317	1	Cuscinetto (ø12xø28x8 mm)	Bearing (ø12xø28x8 mm)	Roulement (ø12xø28x8 mm)	Lager (ø12xø28x8 mm)	Cojinete (ø12xø28x8 mm)	
	12	8000 99703	1	Disco centrifugo	Disc	Disque	Scheibe	Disco	
	13	8000 62725	1	Vite (M6x10 mm)	Screw (M6x10 mm)	Vis (M6x10 mm)	Schraube (M6x10 mm)	Tornillo (M6x10 mm)	
	14	8000 99698	1	Alzavalvola (250)	Valve lifter (250)	Levée de soupape (250)	Ventilaufhebel (250)	Alzavalvula (250)	
	14	8000 A2242	1	Alzavalvola (400-450)	Valve lifter (400-450)	Levée de soupape (400-450)	Ventilaufhebel (400-450)	Alzavalvula (400-450)	
	15	8000 99699	1	Molla	Spring	Ressort	Feder	Resorte	
	16	8000 99700	1	Perno	Pin	Pivot	Bolzen	Perno	

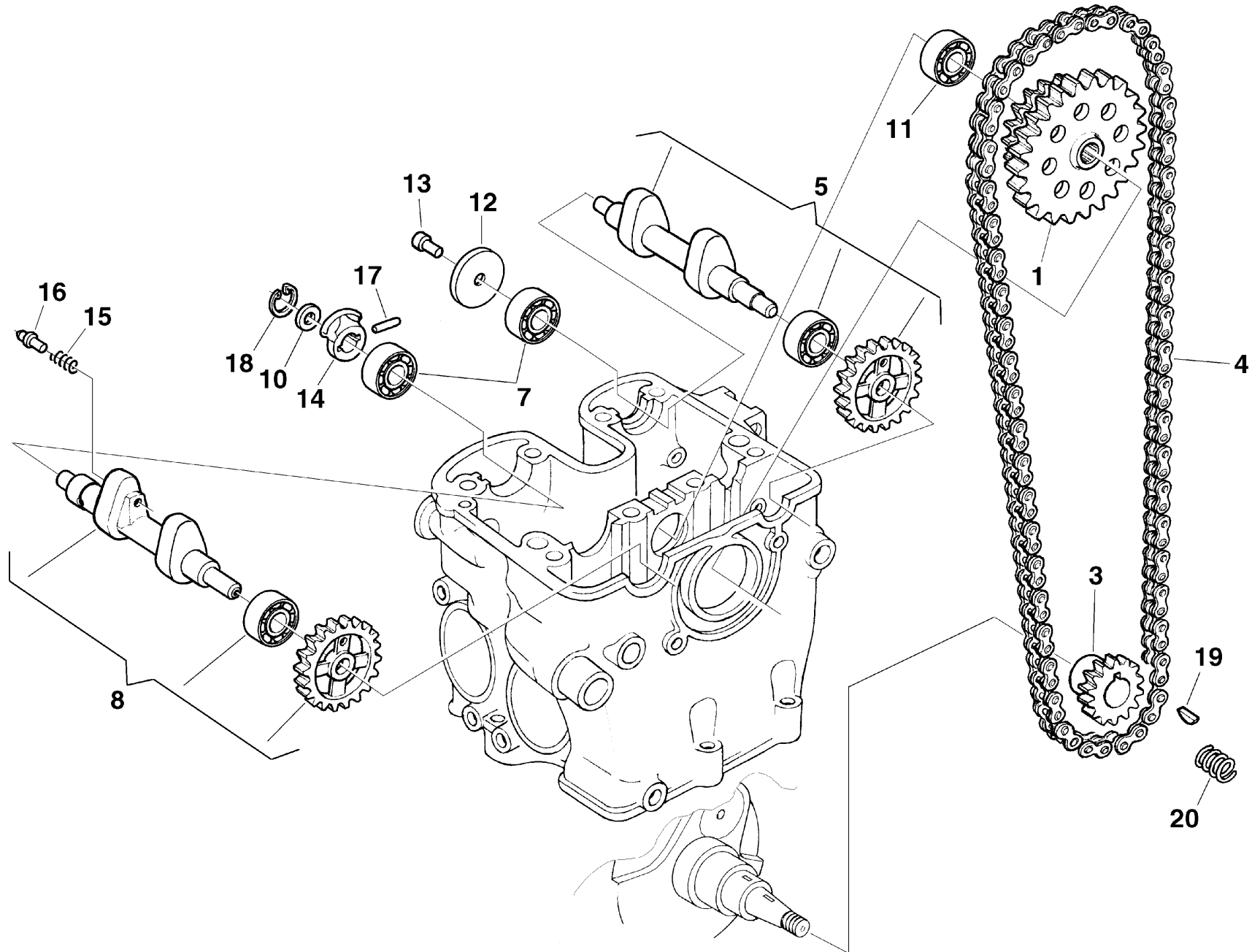



**TC-TE 250- 450,  
SM 400R-450R/ 2004**

TAVOLA  
DRAWING  
TABLE  
BILD  
TABLA

**7**

**DISTRIBUZIONE - VALVE TIMING  
DISTRIBUTION - VENTILSTEUERUNG  
DISTRIBUCION**

Note Notes Marke Notas	Pos. No. N. Index Pos.	N. Cod. Code No. Nr. Code Code Nr N. Cod.	Q.tà Q.ty Q.té M.ge C.ad	DENOMINAZIONE	NAME	DESIGNATION	BESHREIBUNG	DENOMINACION	Validità Validity Validité Gültig Validez
	17	8000 99701	1	Rullino	Roller	Aiguille	Rolle	Rodillo	
	18	66N0 21205	1	Anello di fermo	Stop ring	Bague d'arrêt	Haltering	Anillo de retención	
	19	1615 09801	1	Chiavetta	Woodruff key	Clé woodruff	Federkeil	Lengüeta	
	20	8000 61275	1	Molla	Spring	Ressort	Feder	Resorte	



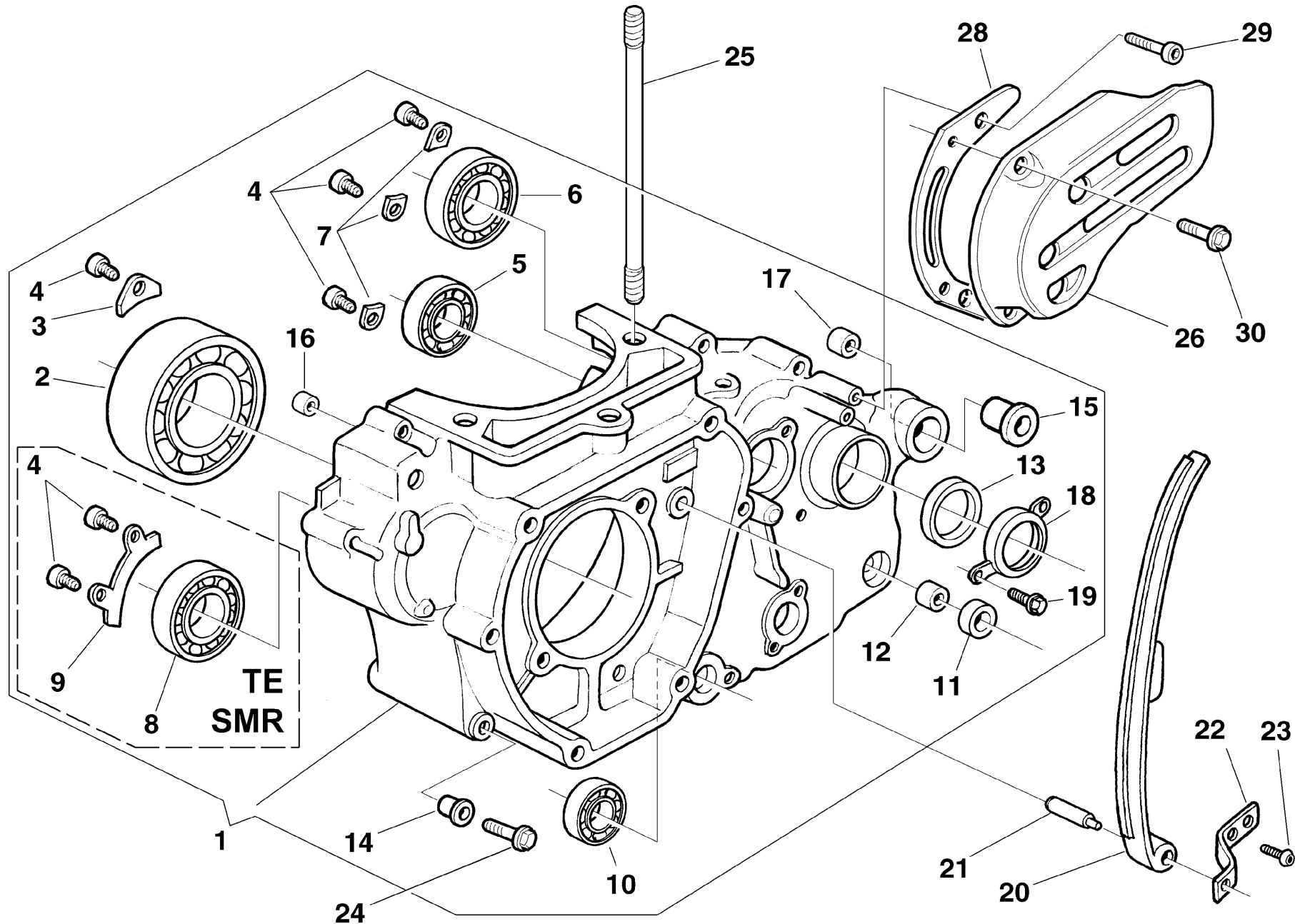



TC-TE 250- 450,  
SM 400R-450R/ 2004

TAVOLA  
DRAWING  
TABLE  
BILD  
TABLA

8

SEMICARTER SINISTRO - L.H. HALF CRANKCASE  
CARTER G. - GEHAUSEDECKELL.  
BANCADA IZQ.

Note Notes Notas	Pos. No. N. Index Pos.	N. Cod. Code No. Nr. Code Code Nr N. Cod.	Q.tà Q.ty M.ge C.ad	DENOMINAZIONE	NAME	DESIGNATION	BESHREIBUNG	DENOMINACION	Validità Validity Validité Gültig Validez
	1	8000 99843	1	Carter motore accoppiati compl. (TE -SMR 450)	Crankcase assy (TE -SMR 450)	Carter compl. (TE -SMR 450)	Kurberlgehaue kpl. (TE -SMR 450)	Carter motor completi (TE -SMR 450)	
	1	8000 A2959	1	Carter motore accoppiati completi (TC - SMR 400)	Crankcase assy (TC - SMR 400)	Carter compl. (TC - SMR 400)	Kurberlgehaue kpl. (TC - SMR 400)	Carter motor completi (TC - SMR 400)	
	2	8000 99846	1	Cuscinetto (ø30xø72x19 mm) ALBERO MOTORE	Bearing (ø30xø72x19 mm) CRANKSHAFT	Roulement (ø30xø72x19 mm) VILEBREQUIN	Lager (ø30xø72x19 mm) KURBEWELLE	Cojinete (ø30xø72x19 mm) CIGÜEÑAL	
	3	8000 97941	2	Piastrina	Plate	Plaquette	Plättchen	Placa	
Y	4	8A00 55241	7	Vite (M6X14 mm)	Screw (M6X14 mm)	Vis (M6X14 mm)	Schraube (M6X14 mm)	Tornillo (M6X14 mm)	
C	4	8A00 55241	5	Vite (M6X14 mm)	Screw (M6X14 mm)	Vis (M6X14 mm)	Schraube (M6X14 mm)	Tornillo (M6X14 mm)	
	5	8000 99847	1	Cuscinetto (ø17xø40x12 mm) ALBERO PRIMARIO	Bearing (ø17xø40x12 mm) MAIN SHAFT	Roulement (ø17xø40x12 mm) ARBRE PRIMAIRE	Lager (ø17xø40x12 mm) HAUPTWELLE	Cojinete (ø17xø40x12 mm) EJE PRIMARIO	
	6	8000 43567	1	Cuscinetto (ø25xø52x15 mm) ALBERO SECONDARIO	Bearing (ø25xø52x15 mm) LAYSHAFT	Roulement (ø25xø52x15 mm) ARBRE SECONDAIRE	Lager (ø25xø52x15 mm) VORGELEGEWELLE	Cojinete (ø25xø52x15 mm) EJE SECUNDARIO	
	7	8000 51746	3	Piastrina	Plate	Plaquette	Plättchen	Placa	
Y	8	8A00 19768	1	Cuscinetto (ø15xø42x13 mm) CONTRALBERO	Bearing (ø15xø42x13 mm) COUNTERSHAFT	Roulement (ø15xø42x13 mm) ARBRE DE BALAN.	Lager (ø15xø42x13 mm) WORGELEGEWELLE	Cojinete (ø15xø42x13 mm) CONTRA-EJE	
Y	9	8000 91602	1	Piastrina	Plate	Plaquette	Plättchen	Placa	
	10	8000 65884	1	Cuscinetto (ø25xø37x7 mm) ALBERO COM. FORCELLE CAMBIO	Bearing (ø25xø37x7 mm) GEARBOX GEAR SHAFT	Roulement (ø25xø37x7 mm) ARBRE COMM. FOURCHES	Lager (ø25xø37x7 mm) ANTRIEBSWELLE SCHALTGABEL	Cojinete (ø25xø37x7 mm) EJE MANDO HORQUILLA CAMBIO	
	11	8000 34451	1	Anello di tenuta (ø12xø19x5 mm)	Seal ring (ø12xø19x5 mm)	Bague d'étanchéité (ø12xø19x5 mm)	Dichtungsring (ø12xø19x5 mm)	Anillo de retención (ø12xø19x5 mm)	
	12	8A00 65847	1	Bussola	Bushing	Douille	Buchse	Manguito	
	13	8000 59977	1	Anello di tenuta (ø32xø40x5 mm)	Seal ring (ø32xø40x5 mm)	Bague d'étanchéité (ø32xø40x5 mm)	Dichtungsring (ø32xø40x5 mm)	Anillo de retención (ø32xø40x5 mm)	
	14	1610 77703	2	Bussola	Bushing	Douille	Buchse	Manguito	
	15	8000 73500	1	Bussola	Bushing	Douille	Buchse	Manguito	
	16	1610 77601	1	Bussola	Bushing	Douille	Buchse	Manguito	
	17	1614 59002	1	Bussola	Bushing	Douille	Buchse	Manguito	
	18	8000 99850	1	Piastrina	Plate	Plaquette	Plättchen	Placa	
	19	8000 66525	2	Vite	Screw	Vis	Schraube	Tornillo	
	20	8000 91555	1	Pattino catena	Chain slider	Glissière de chaine	Gleitbahn	Platode cadena	
	21	8000 99704	1	Perno	Pin	Pivot	Bolzen	Perno	

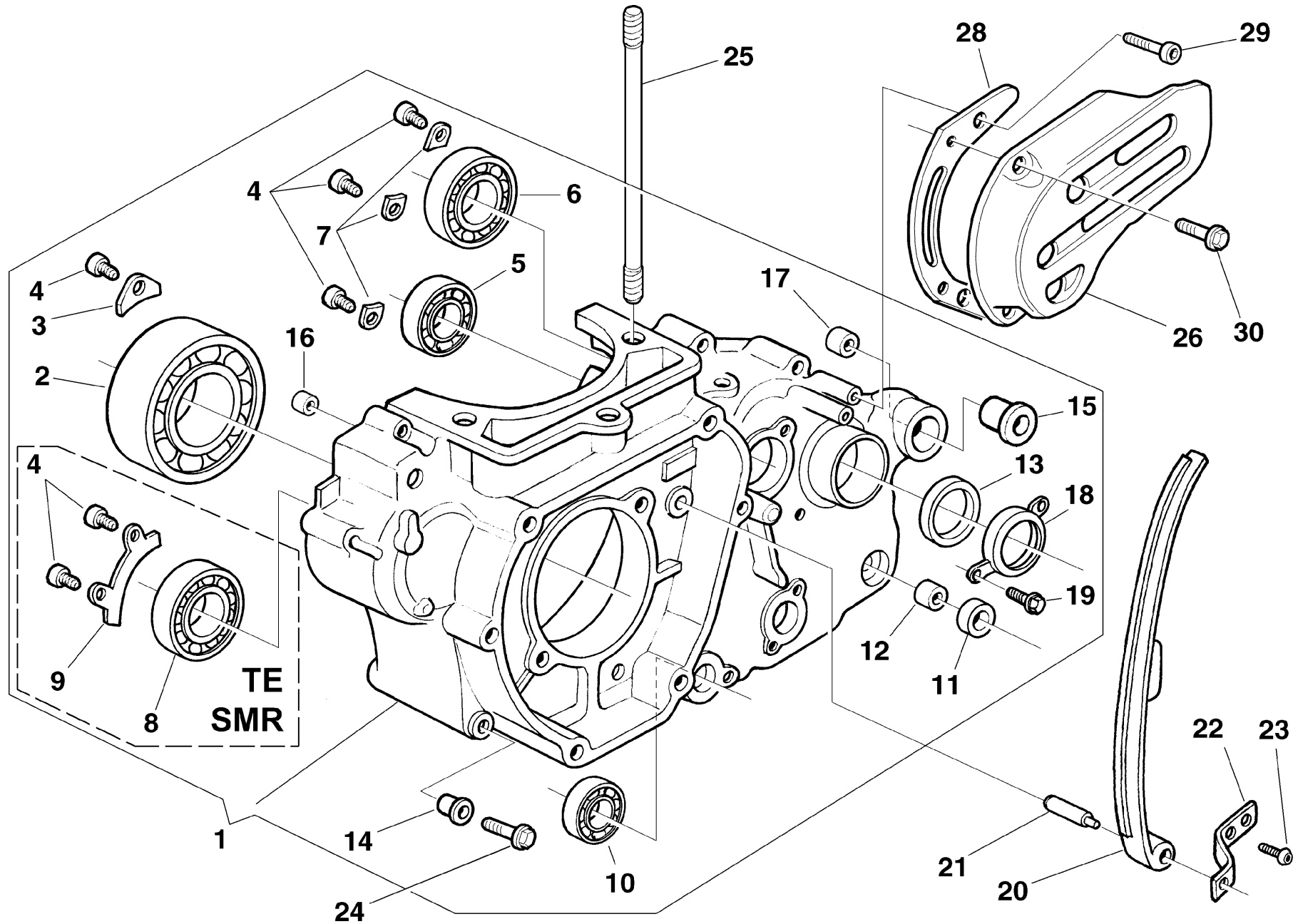



**TC-TE 250- 450,  
SM 400R-450R/ 2004**

TAVOLA  
DRAWING  
TABLE  
BILD  
TABLA

**8**

**SEMICARTER SINISTRO - L.H. HALF CRANKCASE  
CARTER G. - GEHAUSEDECKEL L.  
BANCADA IZQ.**

Note Notes Markes Notas	Pos. No. N. Index Pos.	N. Cod. Code No. Nr. Code Code Nr N. Cod.	Q.tà Q.ty Q.te M.ge C.ad	DENOMINAZIONE	NAME	DESIGNATION	BESHREIBUNG	DENOMINACION	Validità Validity Validité Gültig Validez
	22	8000 99705	1	Piastrina	Plate	Plaquette	Plättchen	Placa	
	23	8000 66774	2	Vite	Screw	Vis	Schraube	Tornillo	
	24	8000 62731	12	Vite (M6X45 mm)	Screw (M6X45 mm)	Vis (M6X45 mm)	Schraube (M6X45 mm)	Tornillo (M6X45 mm)	
	25	8C00 81650	2	Prigioniero (M10x165 mm) (250)	Stud bolt (M10x165 mm) (250)	Prisonnier (M10x165 mm) (250)	Stiftschraube (M10x165 mm) (250)	Prisionero (M10x165 mm) (250)	
	25	8B00 81650	2	Prigioniero (M10x185 mm) (400-450)	Stud bolt (M10x185 mm) (400-450)	Prisonnier (M10x185 mm) (400-450)	Stiftschraube (M10x185 mm) (400-450)	Prisionero (M10x185 mm) (400-450)	
	26	8000 66973	1	Coperchio pignone catena	Pinion cover	Couvercle pignon	Ritzeldeckel	Tapa piñón	
	28	8000 A0663	1	Piastra guidacatena	Plate	Plaquette	Plättchen	Placa	
	29	8A00 55241	2	Vite (M6x14 mm)	Screw (M6x14 mm)	Vis (M6x14 mm)	Schraube (M6x14 mm)	Tornillo (M6x14 mm)	
	30	8000 62725	2	Vite (M6x10 mm)	Screw (M6x10 mm)	Vis (M6x10 mm)	Schraube (M6x10 mm)	Tornillo (M6x10 mm)	

Vedi Tavola 12  
See Drawing 12  
Voir Table 12  
Sehen Bild 12  
Ver Tabla12

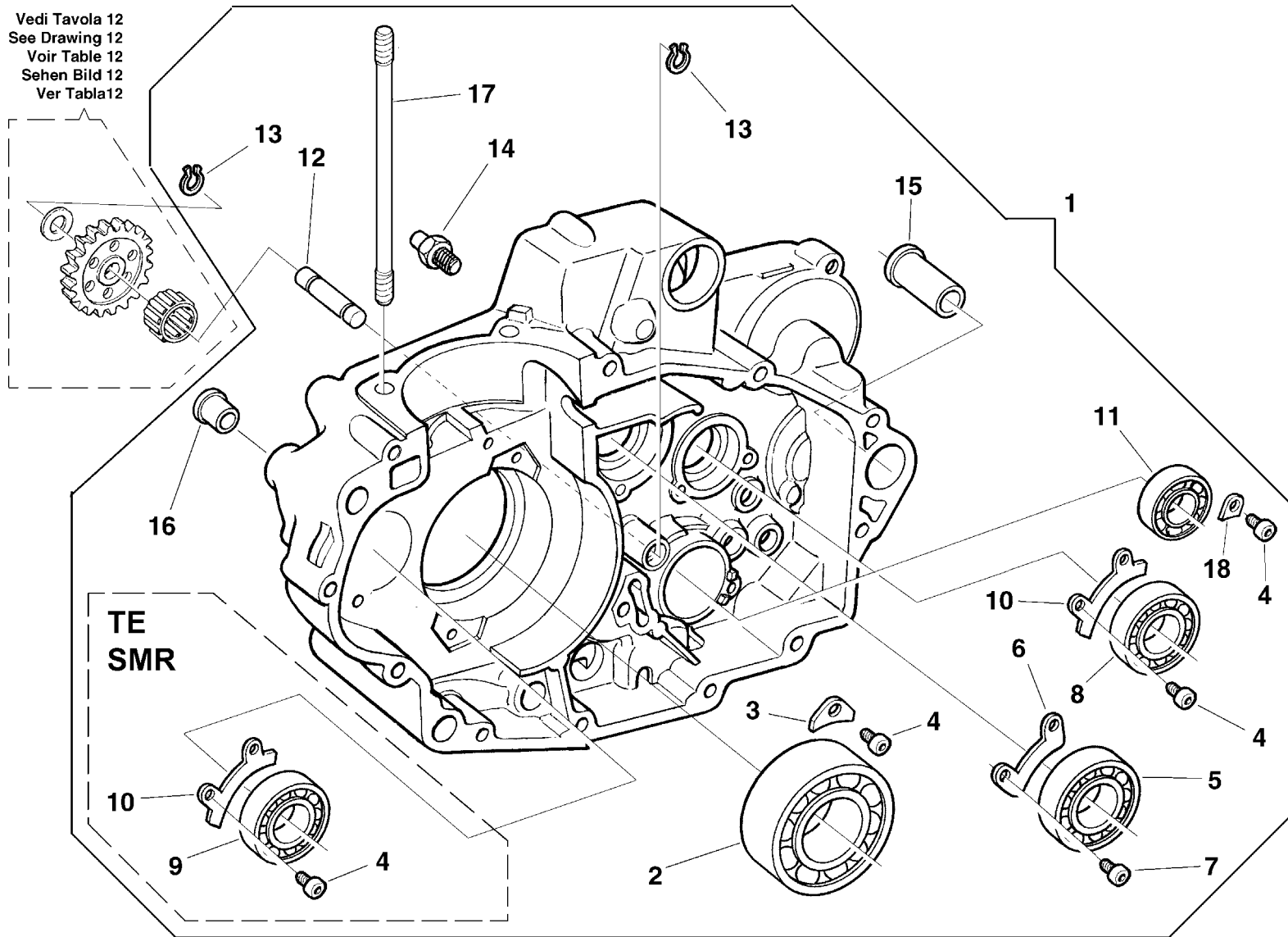





**TC-TE 250- 450,  
SM 400R-450R/ 2004**

TAVOLA  
DRAWING  
TABLE  
BILD  
TABLA

**9**

**SEMICARTER DESTRO - R.H. HALF CRANKCASE  
CARTER D. - GEHAUSEDECKEL R.  
BANCADADER.**

Note Notes Marka Notas	Pos. No. N. Index Pos.	N. Cod. Code No. Nr. Code Code Nr N. Cod.	Q.tà Q.ty Q.te M.ge C.ad	DENOMINAZIONE	NAME	DESIGNATION	BESHREIBUNG	DENOMINACION	Validità Validity Validité Gültig Validez
	1	8000 99843	1	Carter motore accoppiati compl. (SMR 450 - TE)	Crankcase assy (SMR 450 - TE)	Carter compl. (SMR 450 - TE)	Kurberlgehaue kpl. (SMR 450 - TE)	Carter motor completi (SMR 450 - TE)	
	1	8000 A2959	1	Carter motore accoppiati completi (SMR 400 - TC)	Crankcase assy (SMR 400 - TC)	Carter compl. (SMR 400 - TC)	Kurberlgehaue kpl. (SMR 400 - TC)	Carter motor completi (SMR 400 - TC)	
	2	8000 99846	1	Cuscinetto (ø30xø72x19 mm) ALBERO MOTORE	Bearing (ø30xø72x19 mm) CRANKSHAFT	Roulement (ø30xø72x19 mm) VILEBREQUIN	Lager (ø30xø72x19 mm) KURBEWELLE	Cojinete (ø30xø72x19 mm) CIGÜÑAL	
	3	8000 97941	2	Piastrina	Plate	Plaquette	Plättchen	Placa	
<b>Y</b>	4	8A00 55241	7	Vite	Screw	Vis	Schraube	Tornillo	
<b>C</b>	4	8A00 55241	5	Vite	Screw	Vis	Schraube	Tornillo	
	5	8000 24952	1	Cuscinetto (ø25xø52x15 mm) ALBERO PRIMARIO	Bearing (ø25xø52x15 mm) MAIN SHAFT	Roulement (ø25xø52x15 mm) ARBRE PRIMAIRE	Lager (ø25xø52x15 mm) HAUPTWELLE	Cojinete (ø25xø52x15 mm) EJE PRIMARIO	
	6	8A00 42100	1	Piastrina	Plate	Plaquette	Plättchen	Placa	
	7	8B00 55241	2	Vite	Screw	Vis	Schraube	Tornillo	
	8	8000 17040	1	Cuscinetto (ø20xø42x12 mm) ALBERO SECONDARIO	Bearing (ø20xø42x12 mm) LAYSHAFT	Roulement (ø20xø42x12 mm) ARBRE SECONDAIRE	Lager (ø20xø42x12 mm) VORGELEGEWELLE	Cojinete (ø20xø42x12 mm) EJE SECUNDARIO	
<b>Y</b>	9	8A00 19768	1	Cuscinetto (ø15xø42x13 mm) CONTRALBERO	Bearing (ø15xø42x13 mm) COUNTERSHAFT	Roulement (ø15xø42x13 mm) ARBRE DE BALAN.	Lager (ø15xø42x13 mm) WORGELEGEWELLE	Cojinete (ø15xø42x13 mm) CONTRA-EJE	
<b>Y</b>	10	8000 91602	2	Piastrina	Plate	Plaquette	Plättchen	Placa	
<b>C</b>	10	8000 91602	1	Piastrina	Plate	Plaquette	Plättchen	Placa	
	11	8000 85395	1	Cuscinetto (ø25xø42x9 mm) ALBERO COM. FORCELLE CAMBIO	Bearing (ø25xø42x9 mm) GEARBOX GEAR SHAFT	Roulement (ø25xø42x9 mm) ARBRE COMM. FOURCHES	Lager (ø25xø42x9 mm) ANTRIEBSWELLE SCHALTGABEL	Cojinete (ø25xø42x9 mm) EJE MANDO HORQUILLA CAMBIO	
	12	8000 99848	1	Perno	Pin	Pivot	Bolzen	Perno	
	13	66N0 21312	2	Anello di fermo	Stop ring	Bague d'arrêt	Haltering	Anillo de retención	
	14	8B00 66953	1	Perno fermo selettore	Pin	Pivot	Bolzen	Perno	
	15	8000 73500	1	Bussola	Bushing	Douille	Buchse	Manguito	
	16	1610 77703	2	Bussola	Bushing	Douille	Buchse	Manguito	
	17	8C00 81650	2	Prigioniero (M10x165 mm) (250)	Stud bolt (M10x165 mm) (250)	Prisonnier (M10x165 mm) (250)	Stiftschraube (M10x165 mm) (250)	Prisionero (M10x165 mm) (250)	
	17	8B00 81650	2	Prigioniero (M10x185 mm) (400-450)	Stud bolt (M10x185 mm) (400-450)	Prisonnier (M10x185 mm) (400-450)	Stiftschraube (M10x185 mm) (400-450)	Prisionero (M10x185 mm) (400-450)	
	18	8000 51746	1	Piastrina	Plate	Plaquette	Plättchen	Placa	

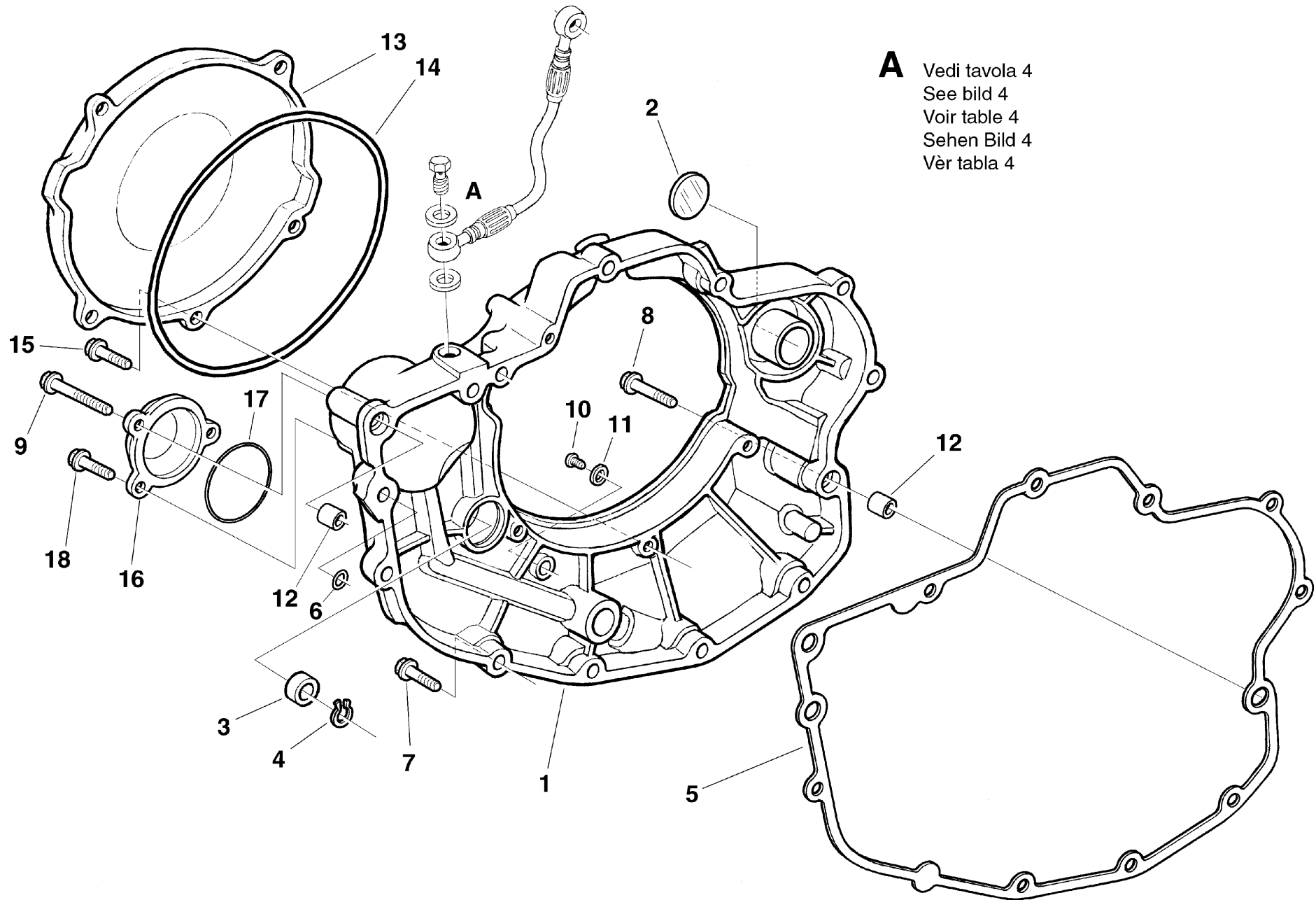

**A** Vedi tavola 4  
See bild 4  
Voir table 4  
Sehen Bild 4  
Vër tabla 4



**TC-TE 250- 450,  
SM 400R-450R/ 2004**

TAVOLA  
DRAWING  
TABLE  
BILD  
TABLA

**10**

**COPERCHI SEMICARTER DESTRO - R.H. HALF CRANKCASE COVERS  
COUVERCLES CARTER D. - GEHAUSEDECKEL R.  
TAPAS BANCADA DER.**

Note Notes Notes Marke Notas	Pos. No. N. Index Pos.	N. Cod. Code No. Nr. Code Code Nr N. Cod.	Q.tà Q.ty Q.te M.ge C.ad	DENOMINAZIONE	NAME	DESIGNATION	BESHREIBUNG	DENOMINACION	Validità Validity Validité Gültig Validez
	1	80A0 99172	1	Coperchio destro	R.H. Cover	Couvercle D.	R. Deckel	Tapa DER.	
	2	8000 A0765	1	Tappo	Plug	Bouchon	Verschluss	Tapòn	
	3	8A00 28855	1	Anello di tenuta (ø12xØ22x6,5 mm)	Seal ring (ø12xØ22x6,5 mm)	Bague d'étanchéité (ø12xØ22x6,5 mm)	Dichtungsring (ø12xØ22x6,5 mm)	Anillo de retención (ø12xØ22x6,5 mm)	
	4	66N0 21258	1	Anello di fermo	Stop ring	Bague d'arrêt	Haltering	Anillo de retención	
	5	8000 99854	1	Guarnizione	Gasket	Garnitue	Dichtung	Junta	
	6	8000 99855	1	Anello OR	O-Ring	Bague OR	O-Ring	Anillo OR	
	7	8000 62729	10	Vite (M6X25 mm)	Screw (M6X25 mm)	Vis (M6X25 mm)	Schraube (M6X25 mm)	Tornillo (M6X25 mm)	
	8	8A00 67545	1	Vite (M6X35 mm)	Screw (M6X35 mm)	Vis (M6X35 mm)	Schraube (M6X35 mm)	Tornillo (M6X35 mm)	
	9	8F00 67545	1	Vite (M6X80 mm)	Screw (M6X80 mm)	Vis (M6X80 mm)	Schraube (M6X80 mm)	Tornillo (M6X80 mm)	
	10	8S00 67545	1	Vite	Screw	Vis	Schraube	Tornillo	
	11	8A00 15960	1	Rosetta piana	Washer	Rondelle	Scheibe	Arandela	
	12	8000 07719	2	Bussola	Bushing	Douille	Buchse	Manguito	
	13	80A0 99173	1	Coperchio frizione (250)	Clutch cover (250)	Couvercle embrayage (250)	Kupplungdeckel (250)	Tapa embrague (250)	
	13	80A0 A0942	1	Coperchio frizione (400-450)	Clutch cover (400-450)	Couvercle embr. (400-450)	Kupplungdeckel (400-450)	Tapa embrague (400-450)	
	14	8000 86878	1	Anello OR	O-Ring	Bague OR	O-Ring	Anillo OR	
	15	8000 62728	5	Vite (M6X20 mm) (250)	Screw (M6X20 mm) (250)	Vis (M6X20 mm) (250)	Schraube (M6X20 mm) (250)	Tornillo (M6X20 mm) (250)	
	15	8000 62729	5	Vite (M6X25 mm) (400-450)	Screw (M6X25 mm) (400-450)	Vis (M6X25 mm) (400-450)	Schraube (M6X25 mm) (400-450)	Tornillo (M6X25 mm) (400-450)	
	16	80A0 91551	1	Coperchio filtro olio	Oil filter cover	Couvercle filtre huile	Deckel	Tapa	
	17	8A00 28553	1	Anello OR	O-Ring	Bague OR	O-Ring	Anillo OR	
	18	8000 62728	2	Vite (M6X20 mm)	Screw (M6X20 mm)	Vis (M6X20 mm)	Schraube (M6X20 mm)	Tornillo (M6X20 mm)	

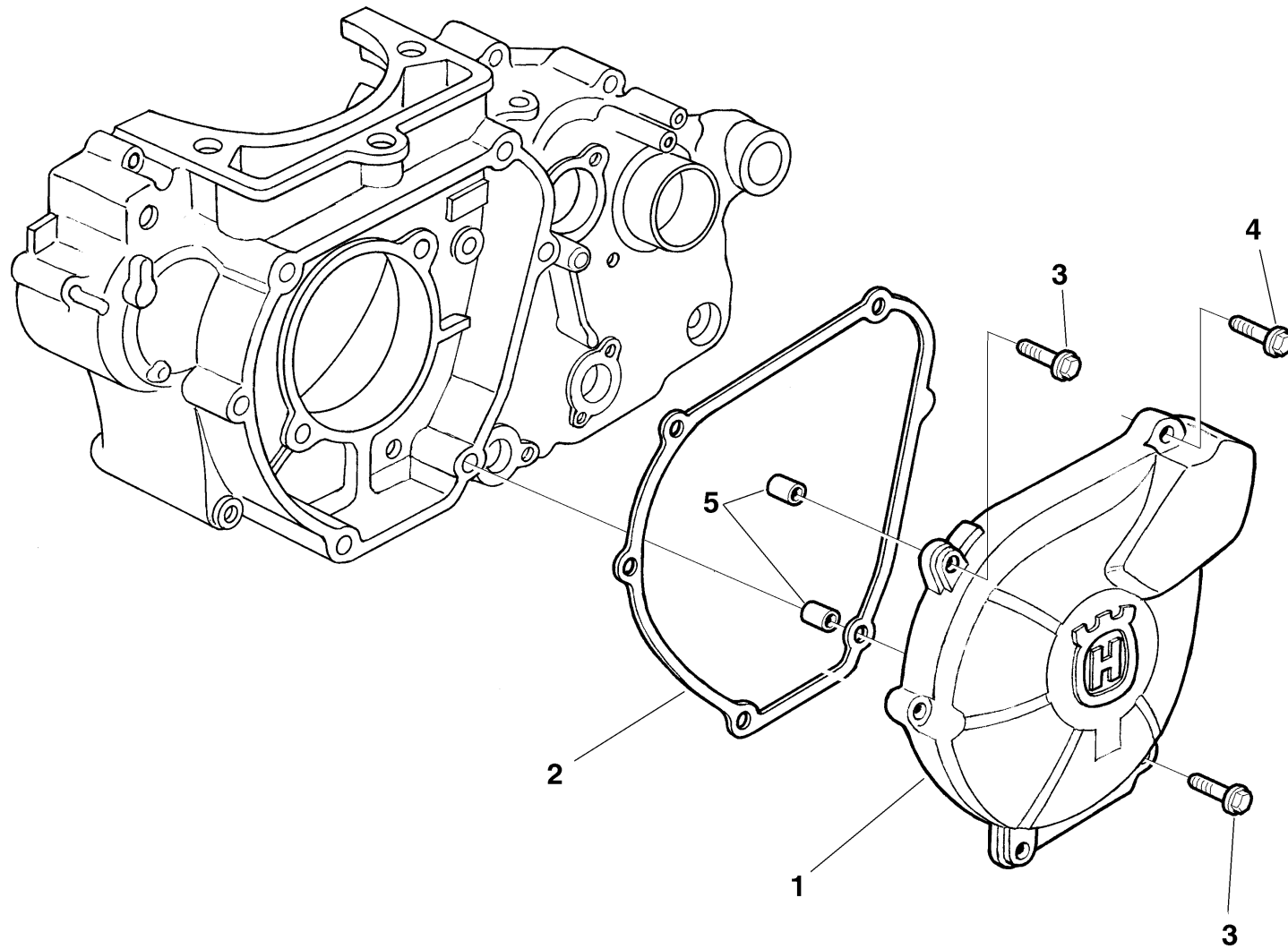



TC-TE 250- 450,  
SM 400R-450R/ 2004

TAVOLA  
DRAWING  
TABLE  
BILD  
TABLA

11

COPERCHI SEMICARTER SINISTRO - L.H. HALF CRANKCASE COVERS  
COUVERCLES CARTER G. - GEHAUSEDECKEL L.  
TAPAS BANCADA IZQ.

Note Notes Marke Notas	Pos. No. N. Index Pos.	N. Cod. Code No. Nr. Code Code Nr N. Cod.	Q.tà Q.ty Q.té M.ge C.ad	DENOMINAZIONE	NAME	DESIGNATION	BESHREIBUNG	DENOMINACION	Validità Validity Validité Gültig Validez
	1	80A0 99174	1	Coperchio accensione (TC 450, TE , SMR)	Ignition cover (TC 450, TE , SMR)	Couvercle allumage (TC 450, TE , SMR)	Zündungdeckel (TC 450, TE , SMR)	Tapa encendido (TC 450, TE , SMR)	
	1	80A0 A1054	1	Coperchio accensione (TC 250)	Ignition cover (TC 250)	Couvercle allumage (TC 250)	Zündungdeckel (TC 250)	Tapa encendido (TC 250)	
	2	8000 99856	1	Guarnizione	Gasket	Garnitue	Dichtung	Junta	
	3	8A00 67545	2	Vite (M6X35 mm)	Screw (M6X35 mm)	Vis (M6X35 mm)	Schraube (M6X35 mm)	Tornillo (M6X35 mm)	
	4	8000 62729	4	Vite (M6X25 mm)	Screw (M6X25 mm)	Vis (M6X25 mm)	Schraube (M6X25 mm)	Tornillo (M6X25 mm)	
	5	8000 07719	2	Bussola	Bushing	Douille	Buchse	Manguito	

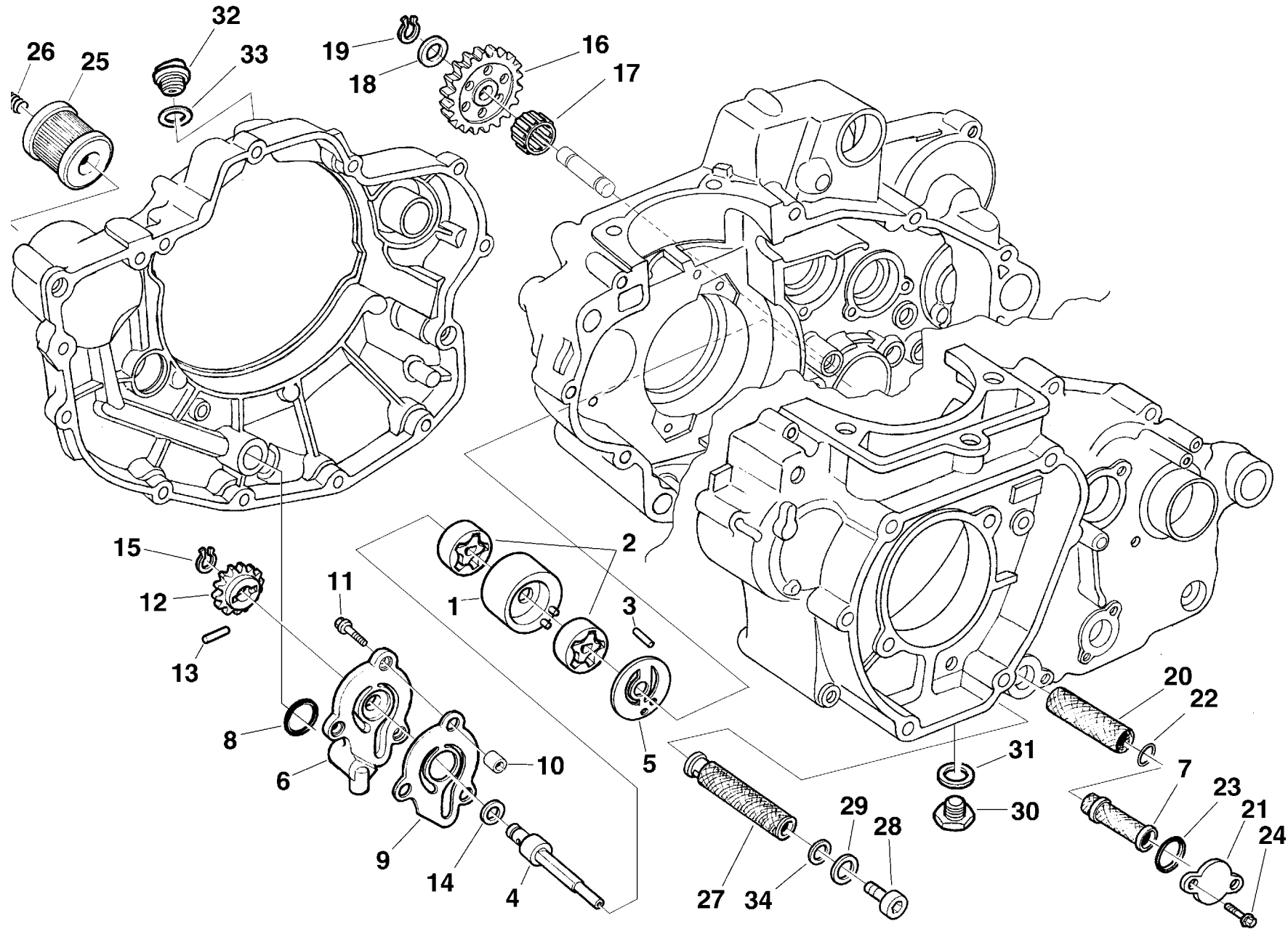





TC-TE 250- 450,  
SM 400R-450R/ 2004

TAVOLA  
DRAWING  
TABLE  
BILD  
TABLA

12

LUBRIFICAZIONE - OIL PUMP  
PUMPE HUILE - MOTORSCHMIERUNG  
LUBRICATION

Note Notes Notas	Pos. No. N. Index Pos.	N. Cod. Code No. Nr. Code Code Nr N. Cod.	Q.tà Q.ty Q.te M.ge C.ad	DENOMINAZIONE	NAME	DESIGNATION	BESHREIBUNG	DENOMINACION	Validità Validity Validité Gültig Validez
	1	8000 99858	1	Corpo porta rotori	Pump body	Corps pompe	Pumpenkörper	Corpo bomba	
	2	8000 82948	2	Rotore recupero olio	Rotor assy.	Rotor compl.	Rotor kpl.	Rotor compl.	
	3	8A00 47773	2	Rullino	Roller	Aiguille	Rolle	Rodillo	
	4	8000 99860	1	Albero pompa lubrificazione	Pump shaft	Arbre pompe	Pumpenwelle	Eje bomba	
	5	8000 99861	1	Distanziale	Spacer	Entretoise	Distanzstück	Separador	
	6	8000 91552	1	Coperchio pompa lubrificazione	Pump cover	Couvercle pompe	Pumpendeckel	Tapa bomba	
	7	8000 72427	1	Filtro a rete interno	Inner filter	Filtre	Filter	Filtro	
	8	8000 25082	1	Anello OR	O-Ring	Bague OR	O-Ring	Anillo OR	
	9	8000 99862	1	Coperchio intermedio	Pump cover	Couvercle pompe	Pumpendeckel	Tapa bomba	
	10	1617 95502	2	Bussola	Bushing	Douille	Buchse	Manguito	
	11	8000 62728	3	Vite (M6X20 mm)	Screw (M6X20 mm)	Vis (M6X20 mm)	Schraube (M6X20 mm)	Tornillo (M6X20 mm)	
	12	8000 99863	1	Ingranaggio condotto (Z=11)	Gear (Z=11)	Engranage (Z=11)	Zahnrad (Z=11)	Engranaje (Z=11)	
	13	8000 47773	1	Rullino	Roller	Aiguille	Rolle	Rodillo	
	14	8E00 34292	1	Rosetta	Washer	Rondelle	Scheibe	Arandela	
	15	8000 21375	1	Anello di fermo	Stop ring	Bague d'arrêt	Haltering	Anillo de retención	
	16	8000 99864	1	Ingranaggio intermedio (Z=24)	Gear (Z=24)	Engranage(Z=24)	Zahnrad (Z=24)	Engranaje (Z=24)	
	17	8000 33718	1	Cuscinetto a rullini (ø12xø16x10 mm)	Needle bearing (ø12xø16x10 mm)	Roulement à aiguilles (ø12xø16x10 mm)	Nadelkäfig (ø12xø16x10 mm)	Cojinete de rodillos (ø12xø16x10 mm)	
	18	8D00 01261	1	Rosetta	Washer	Rondelle	Scheibe	Arandela	
	19	66N0 21202	1	Anello di fermo	Stop ring	Bague d'arrêt	Haltering	Anillo de retención	
	20	8000 72426	1	Filtro a rete esterno	Outer filter	Filtre	Filter	Filtro	
	21	8000 72425	1	Coperchio	Cover	Couvercle	Deckel	Tapa	
	22	8000 26884	1	Anello OR	O-Ring	Bague OR	O-Ring	Anillo OR	
	23	8000 34609	1	Anello OR	O-Ring	Bague OR	O-Ring	Anillo OR	
	24	8000 66525	2	Vite	Screw	Vis	Schraube	Tornillo	
	25	8000 81675	1	Filtro a cartuccia	Cartridge filter	Filtre	Filter	Filtro	
	26	8000 99866	1	Molla	Spring	Ressort	Feder	Resorte	
	27	8A00 74716	1	Filtro a rete	Filter	Filtre	Filter	Filtro	
	28	8000 99711	1	Tappo	Plug	Bouchon	Verschluss	Tapòn	
	29	62N0 15678	1	Rosetta	Washer	Rondelle	Scheibe	Arandela	
	30	8000 73011	1	Tappo scarico olio	Oil drain plug	Bouchon	Verschluss	Tapòn	
	31	62N0 15679	1	Rosetta	Washer	Rondelle	Scheibe	Arandela	
	32	8000 36786	1	Tappo carico olio	Oil filler cap	Bouchon	Verschluss	Tapòn	

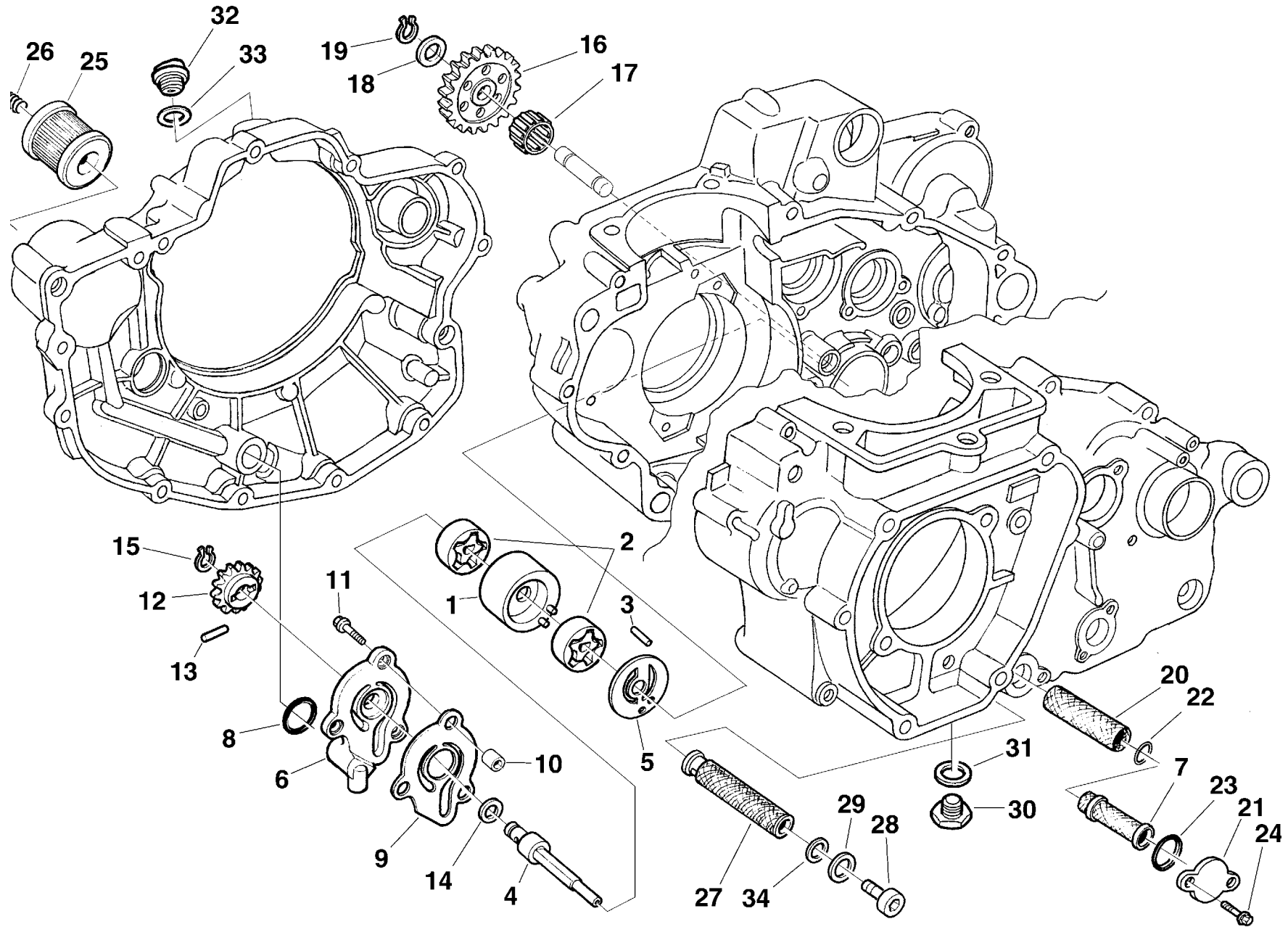



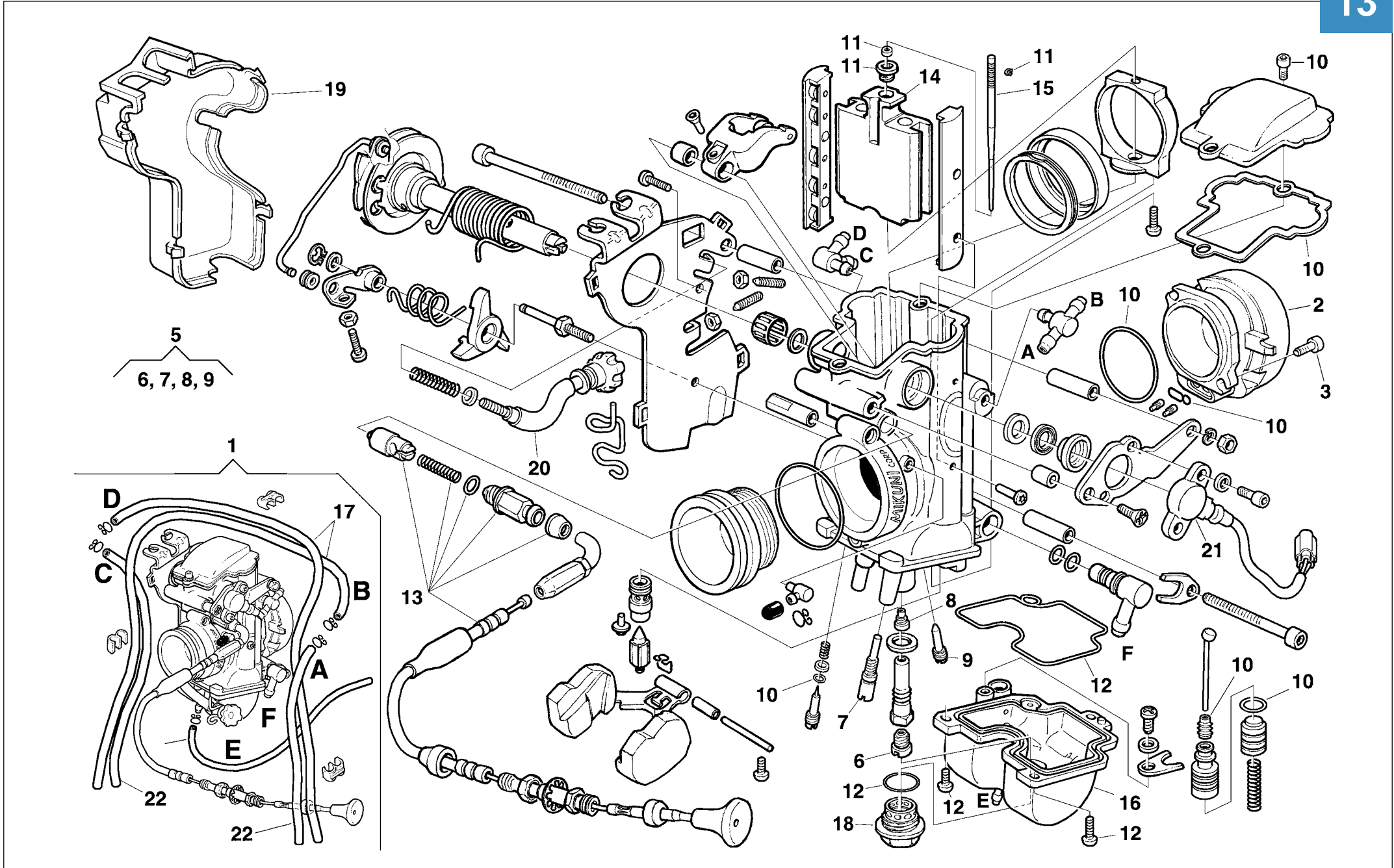

Note Notes Notas	Pos. No. N. Index Pos.	N. Cod. Code No. Nr. Code Code Nr N. Cod.	Q.tà Q.ty Q.te M.ge C.ad	DENOMINAZIONE	NAME	DESIGNATION	BESHREIBUNG	DENOMINACION	Validità Validity Validité Gültig Validez
	1	8000 99710	1	Carburatore TMR 36 (TE 250)	Carburetor TMR 36 (TE 250)	Carburateur TMR 36 (TE 250)	Vegaser TMR 36 (TE 250)	Carburador TMR 36 (TE 250)	
	1	8000 99888	1	Carburatore TMR 38 (TC 250)	Carburetor TMR 38 (TC 250)	Carburateur TMR 38 (TC 250)	Vegaser TMR 38 (TC 250)	Carburador TMR 38 (TC 250)	
	1	8000 A3084	1	Carburatore TMR 38 (400)	Carburetor TMR 38 (400)	Carburateur TMR 38 (400)	Vegaser TMR 38 (400)	Carburador TMR 38 (400)	
	1	8000 A0032	1	Carburatore TMR 41 (450)	Carburetor TMR 41 (450)	Carburateur TMR 41 (450)	Vegaser TMR 41 (450)	Carburador TMR 41 (450)	
	2	8000 A0916	1	Cornetto presa aria (TE 250)	Pipe (TE 250)	Manchon (TE 250)	Muffe (TE 250)	Tubo toma aire (TE 250)	
	2	8000 A0917	1	Cornetto presa aria (TC 250 - SMR 400)	Pipe (TC 250 - SMR 400)	Manchon (TC 250 - SMR 400)	Muffe (TC 250 - SMR 400)	Tubo toma aire (TC 250 - SMR 400)	
	2	8000 A0918	1	Cornetto presa aria (450)	Pipe (450)	Manchon (450)	Muffe (450)	Tubo toma aire (450)	
	3	60N3 02463	2	Vite	Screw	Vis	Schraube	Tornillo	
<b>D</b>	5	8000 A1822	1	Kit carburat. TMR 36 (TE 250)	Carburetor kit TMR 36 (TE 250)	Kit carburateur TMR 36 (TE 250)	Vergaser Kit TMR 36 (TE 250)	Kit carburador TMR 36 (TE 250)	
	5	8000 A1823	1	Kit carburat. TMR 38 (TC 250)	Carburetor kit TMR 38 (TC 250)	Kit carburateur TMR 38 (TC 250)	Vergaser Kit TMR 38 (TC 250)	Kit carburador TMR 38 (TC 250)	
	5	8000 A3091	1	Kit carburat. TMR 38 (400)	Carburetor kit TMR 38 (400)	Kit carburateur TMR 38 (400)	Vergaser Kit TMR 38 (400)	Kit carburador TMR 38 (400)	
	5	8000 A1824	1	Kit carburat. TMR 41 (450)	Carburetor kit TMR 41 (450)	Kit carburateur TMR 41 (450)	Vergaser Kit TMR 41 (450)	Kit carburador TMR 41 (450)	
<b>S</b>	6	8000 80171	1	Getto massimo (150) (TE 250)	Main jet (150) (TE 250)	Gicleur principal (150) (TE 250)	Hauptdüse (150) (TE 250)	Chiclé máximo (150) (TE 250)	
<b>S</b>	6	8H00 80171	1	Getto massimo (155) (TC 250)	Main jet (155) (TC 250)	Gicleur principal (155) (TC 250)	Hauptdüse (155) (TC 250)	Chiclé máximo (155) (TC 250)	
<b>S</b>	6	8D00 80171	1	Getto massimo (165) (SMR 400)	Main jet (165) (SMR 400)	Gicleur principal (165) (SMR 400)	Hauptdüse (165) (SMR 400)	Chiclé máximo (165) (SMR 400)	
<b>S</b>	6	8V00 80171	1	Getto massimo (175) (450)	Main jet (175) (450)	Gicleur principal (175) (450)	Hauptdüse (175) (450)	Chiclé máximo (175) (450)	
¥	6	8C00 80171	1	Getto massimo (160)	Main jet (160)	Gicleur principal (160)	Hauptdüse (160)	Chiclé máximo (160)	
¥	6	8A00 80171	1	Getto massimo (162,5)	Main jet (162,5)	Gicleur principal (162,5)	Hauptdüse (162,5)	Chiclé máximo (162,5)	
¥	6	8E00 80171	1	Getto massimo (167,5)	Main jet (167,5)	Gicleur principal (167,5)	Hauptdüse (167,5)	Chiclé máximo (167,5)	
¥	6	8T00 80171	1	Getto massimo (170)	Main jet (170)	Gicleur principal (170)	Hauptdüse (170)	Chiclé máximo (170)	
*	6	8S00 80171	1	Getto massimo (145)	Main jet (145)	Gicleur principal (145)	Hauptdüse (145)	Chiclé máximo (145)	
*	6	8F00 80171	1	Getto massimo (147,5)	Main jet (147,5)	Gicleur principal (147,5)	Hauptdüse (147,5)	Chiclé máximo (147,5)	

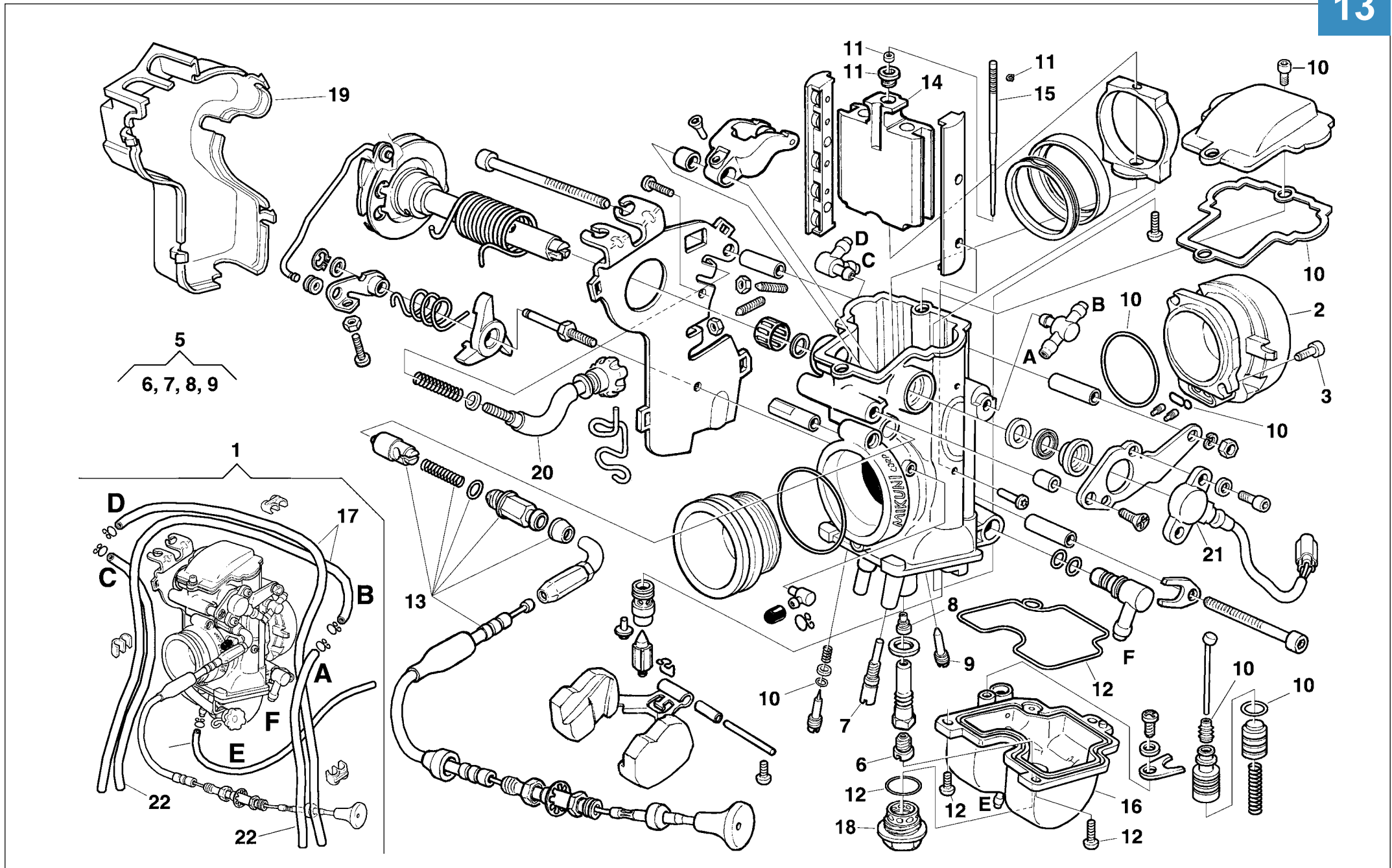



Note Notes Marka Notas	Pos. No. N. Index Pos.	N. Cod. Code No. Nr. Code Code Nr N. Cod.	Q.tà Q.ty Q.té M.ge C.ad	DENOMINAZIONE	NAME	DESIGNATION	BESHREIBUNG	DENOMINACION	Validità Validity Validité Gültig Validez
*	6	8G00 80171	1	Getto massimo (152,5)	Main jet (152,5)	Gicleur principal (152,5)	Hauptdüse (152,5)	Chiclé máximo (152,5)	
*	6	8H00 80171	1	Getto massimo (155)	Main jet (155)	Gicleur principal (155)	Hauptdüse (155)	Chiclé máximo (155)	
**	6	8000 80171	1	Getto massimo (150)	Main jet (150)	Gicleur principal (150)	Hauptdüse (150)	Chiclé máximo (150)	
**	6	8G00 80171	1	Getto massimo (152,5)	Main jet (152,5)	Gicleur principal (152,5)	Hauptdüse (152,5)	Chiclé máximo (152,5)	
**	6	8B00 80171	1	Getto massimo (157,5)	Main jet (157,5)	Gicleur principal (157,5)	Hauptdüse (157,5)	Chiclé máximo (157,5)	
**	6	8C00 80171	1	Getto massimo (160)	Main jet (160)	Gicleur principal (160)	Hauptdüse (160)	Chiclé máximo (160)	
***	6	8E00 80171	1	Getto massimo (167,5)	Main jet (167,5)	Gicleur principal (167,5)	Hauptdüse (167,5)	Chiclé máximo (167,5)	
***	6	8T00 80171	1	Getto massimo (170)	Main jet (170)	Gicleur principal (170)	Hauptdüse (170)	Chiclé máximo (170)	
***	6	8U00 80171	1	Getto massimo (172,5)	Main jet (172,5)	Gicleur principal (172,5)	Hauptdüse (172,5)	Chiclé máximo (172,5)	
***	6	8W00 80171	1	Getto massimo (177,5)	Main jet (177,5)	Gicleur principal (177,5)	Hauptdüse (177,5)	Chiclé máximo (177,5)	
<b>S</b>	7	8K00 A1804	1	Getto minimo (22,5) (TE 250)	Idle jet (22,5) (TE 250)	Gicl. minimum (22,5) (TE 250)	Leerlaufdüse (22,5) (TE 250)	Chic. mínimo (22,5) (TE 250)	
<b>S</b>	7	8K00 A1804	1	Getto minimo (22,5) (TC 250)	Idle jet (22,5) (TC 250)	Gicl. minimum (22,5) (TC 250)	Leerlaufdüse (22,5) (TC 250)	Chic. mínimo (22,5) (TC 250)	
<b>S</b>	7	8H00 A1804	1	Getto minimo (25) (400)	Idle jet (25) (400)	Gicleur minimum (25) (400)	Leerlaufdüse (25) (400)	Chiclé mínimo (25) (400)	
<b>S</b>	7	8000 A1804	1	Getto minimo (30) (450)	Idle jet (30) (450)	Gicleur minimum (30) (450)	Leerlaufdüse (30) (450)	Chiclé mínimo (30) (450)	
¥	7	8K00 A1804	1	Getto minimo (22,5)	Idle jet (22,5)	Gicleur minimum (22,5)	Leerlaufdüse (22,5)	Chiclé mínimo (22,5)	
¥	7	8G00 A1804	1	Getto minimo (27,5)	Idle jet (27,5)	Gicleur minimum (27,5)	Leerlaufdüse (27,5)	Chiclé mínimo (27,5)	
*	7	8J00 A1804	1	Getto minimo (20)	Idle jet (20)	Gicleur minimum (20)	Leerlaufdüse (20)	Chiclé mínimo (20)	
*	7	8H00 A1804	1	Getto minimo (25)	Idle jet (25)	Gicleur minimum (25)	Leerlaufdüse (25)	Chiclé mínimo (25)	
**	7	8J00 A1804	1	Getto minimo (20)	Idle jet (20)	Gicleur minimum (20)	Leerlaufdüse (20)	Chiclé mínimo (20)	
**	7	8H00 A1804	1	Getto minimo (25)	Idle jet (25)	Gicleur minimum (25)	Leerlaufdüse (25)	Chiclé mínimo (25)	
***	7	8H00 A1804	1	Getto minimo (25)	Idle jet (25)	Gicleur minimum (25)	Leerlaufdüse (25)	Chiclé mínimo (25)	
***	7	8G00 A1804	1	Getto minimo (27,5)	Idle jet (27,5)	Gicleur minimum (27,5)	Leerlaufdüse (27,5)	Chiclé mínimo (27,5)	
***	7	8000 A1804	1	Getto minimo (30)	Idle jet (30)	Gicleur minimum (30)	Leerlaufdüse (30)	Chiclé mínimo (30)	
***	7	8A00 A1804	1	Getto minimo (32,5)	Idle jet (32,5)	Gicleur minimum (32,5)	Leerlaufdüse (32,5)	Chiclé mínimo (32,5)	
***	7	8B00 A1804	1	Getto minimo (35)	Idle jet (35)	Gicleur minimum (35)	Leerlaufdüse (35)	Chiclé mínimo (35)	
<b>S</b>	8	8000 A1806	1	Polverizzatore (P4)	Fuel nozzle (P4)	Pulvérisateur (P4)	Einspritzdüse (P4)	Pulverizador (P4)	
¥	8	8A00 A1806	1	Polverizzatore (P3)	Fuel nozzle (P3)	Pulvérisateur (P3)	Einspritzdüse (P3)	Pulverizador (P3)	
¥	8	8B00 A1806	1	Polverizzatore (P5)	Fuel nozzle (P5)	Pulvérisateur (P5)	Einspritzdüse (P5)	Pulverizador (P5)	
*	8	8A00 A1806	1	Polverizzatore (P3)	Fuel nozzle (P3)	Pulvérisateur (P3)	Einspritzdüse (P3)	Pulverizador (P3)	
*	8	8B00 A1806	1	Polverizzatore (P5)	Fuel nozzle (P5)	Pulvérisateur (P5)	Einspritzdüse (P5)	Pulverizador (P5)	
**	8	8A00 A1806	1	Polverizzatore (P3)	Fuel nozzle (P3)	Pulvérisateur (P3)	Einspritzdüse (P3)	Pulverizador (P3)	
**	8	8B00 A1806	1	Polverizzatore (P5)	Fuel nozzle (P5)	Pulvérisateur (P5)	Einspritzdüse (P5)	Pulverizador (P5)	
***	8	8A00 A1806	1	Polverizzatore (P3)	Fuel nozzle (P3)	Pulvérisateur (P3)	Einspritzdüse (P3)	Pulverizador (P3)	

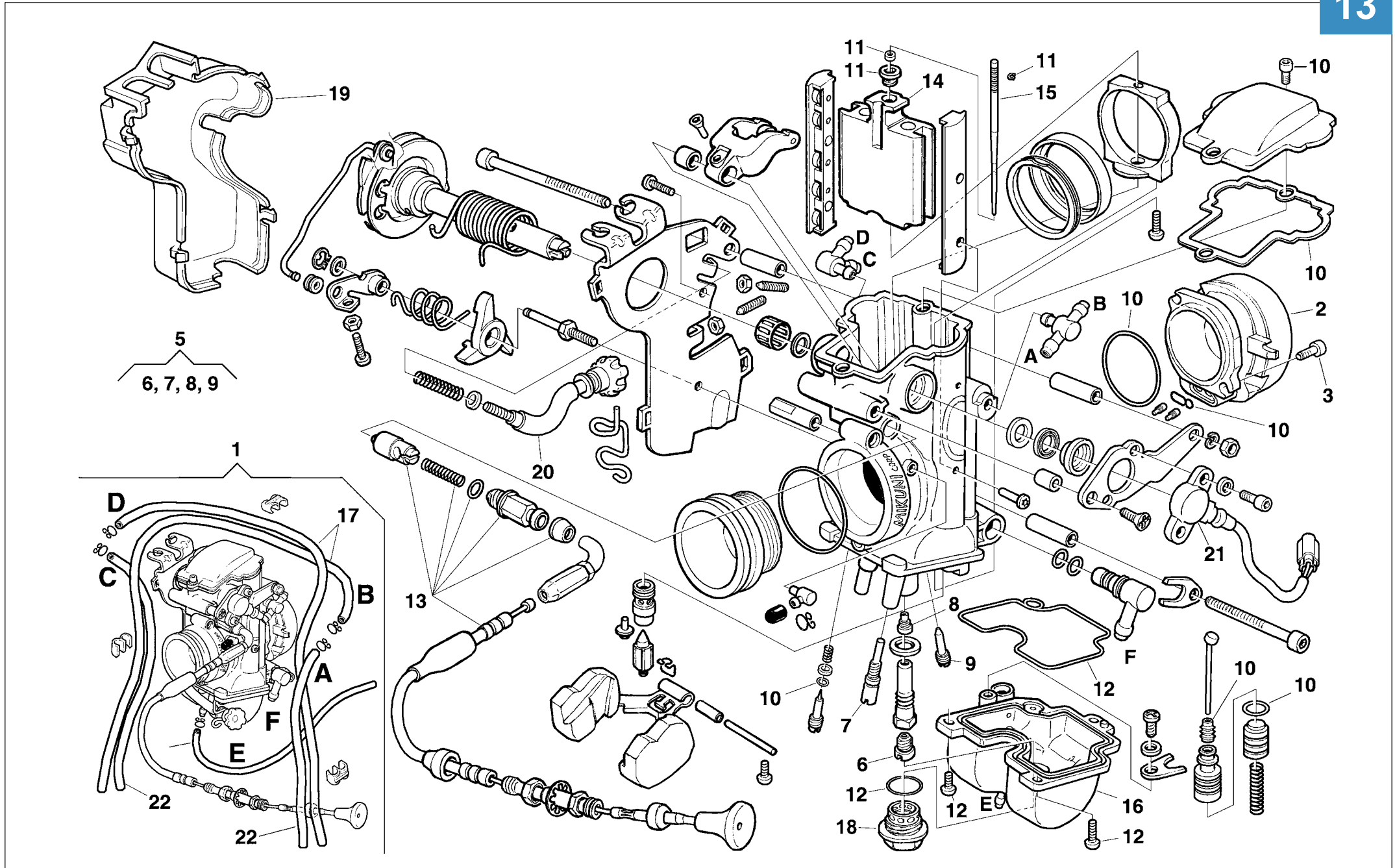



TC-TE 250- 450,  
SM 400R-450R/ 2004

TAVOLA  
DRAWING  
TABLE  
BILD  
TABLA

13

CARBURATORE-CARBURETOR  
CARBURATEUR-VERGASER  
CARBURADOR

(MIKUNI)

Note Notes Notas	Pos. No. Index Pos.	N. Cod. Code No. Nr. Code Code Nr N. Cod.	Q.tà Q.ty Q.té M.ge C.ad	DENOMINAZIONE	NAME	DESIGNATION	BESHREIBUNG	DENOMINACION	Validità Validity Validité Gültig Validez
***	8	8B00 A1806	1	Polverizzatore (P5)	Fuel nozzle (P5)	Pulvérisateur (P5)	Einspritzdüse (P5)	Pulverizador (P5)	
S	9	8000 A1809	1	Getto pompa (30) (400 - 450)	Pump jet (30) (400 - 450)	Gicleur pompe (30) (400-450)	Pumpendüse (30) (400-450)	Chiclé bomba (30) (400-450)	
S	9	8000 A1809	1	Getto pompa (30) (TE 250)	Pump jet (30) (TE 250)	Gicleur pompe (30) (TE 250)	Pumpendüse (30) (TE 250)	Chiclé bomba (30) (TE 250)	
S	9	8A00 A1809	1	Getto pompa (35) (TC 250)	Pump jet (35) (TC 250)	Gicleur pompe (35) (TC 250)	Pumpendüse (35) (TC 250)	Chiclé bomba (35) (TC 250)	
¥	9	8A00 A1809	1	Getto pompa (35)	Pump jet (35)	Gicleur pompe (35)	Pumpendüse (35)	Chiclé bomba (35)	
*	9	8A00 A1809	1	Getto pompa (35)	Pump jet (35)	Gicleur pompe (35)	Pumpendüse (35)	Chiclé bomba (35)	
*	9	8B00 A1809	1	Getto pompa (40)	Pump jet (40)	Gicleur pompe (40)	Pumpendüse (40)	Chiclé bomba (40)	
**	9	8000 A1809	1	Getto pompa (30)	Pump jet (30)	Gicleur pompe (30)	Pumpendüse (30)	Chiclé bomba (30)	
***	9	8A00 A1809	1	Getto pompa (35)	Pump jet (35)	Gicleur pompe (35)	Pumpendüse (35)	Chiclé bomba (35)	
	10	8000 A1794	1	Kit O Ring - viti	O Ring - Screw kit	Kit O Rings - Vis	O Rings - Schrauben Kit	Kit O Rings - Tornillos	
	11	8000 A1796	1	Kit getto- Polverizzatore	Jet-Fuel nozzle kit	Kit Gicleur - Pulvérisateur	Düse- Einspritzdüse Kit	Kit Chiclé - Pulverizador	
	12	8000 A1795	1	Kit O Ring - viti	O Rings - Screws kit	Kit O Rings - Vis	O Rings - Schrauben Kit	Kit O Rings - Tornillos	
	13	8000 A1797	1	Kit STARTER	STARTER kit	Kit DEMARRAGE	STARTER kit	Kit ARRANQUE	
	14	8A00 A1807	1	Valvola gas (1.0)	Throttle valve (1.0)	Papillon de gaz (1.0)	Drosselklappe (1.0)	Válvula (1.0)	
	15	8000 A1808	1	Spillo conico (52)	Needle (52)	Pointeau conique (52)	Kon. Nadel (52)	Pasador cónico (52)	
	16	8000 A1810	1	Vaschetta completa (250)	Chamber assy. (250)	Cuvette compl. (250)	Becken kpl (250)	Cubeta compl. (250)	
	16	8000 A1801	1	Vaschetta completa (400 - 450)	Chamber assy. (400 - 450)	Cuvette compl. (400 - 450)	Becken kpl (400 - 450)	Cubeta compl. (400 - 450)	
	17	8000 A1800	2	Tubazione (L=750 mm)	Pipe (L=750 mm)	Tuyau (L=750 mm)	Rohr (L=750 mm)	Tubo (L=750 mm)	
	18	8000 A1803	1	Tappo	Plug	Bouchon	Verschluss	Tapón	
	19	8000 A1798	1	Coperchio	Cover	Couvercle	Deckel	Tapa	
	20	8000 A1799	1	Cavo regolazione	Adjusting cable	Fil de reglage	Reglerkabel	Trans. de regulacion	
	21	8000 A1802	1	Sensore	Sensor	Sensor	Sensor	Sensór	
	22	8A00 A1800	2	Tubazione (L=550 mm)	Pipe (L=550 mm)	Tuyau (L=550 mm)	Rohr (L=550 mm)	Tubo (L=550 mm)	
¥				FORNITO NEL KIT	SUPPLIED IN BAG	SON FOURNIES EN UNITES	SIND IM UMSCHLAG BEZ	PROVISTO EN GRUPO	
				8000 A3091	8000 A3091	8000 A3091	8000 A3091	8000 A3091	
*				FORNITO NEL KIT	SUPPLIED IN BAG	SON FOURNIES EN UNITES	SIND IM UMSCHLAG BEZ	PROVISTO EN GRUPO	
				8000 A1822	8000 A1822	8000 A1822	8000 A1822	8000 A1822	
**				FORNITO NEL KIT	SUPPLIED IN BAG	SON FOURNIES EN UNITES	SIND IM UMSCHLAG BEZ	PROVISTO EN GRUPO	
				8000 A1823	8000 A1823	8000 A1823	8000 A1823	8000 A1823	
***				FORNITO NEL KIT	SUPPLIED IN BAG	SON FOURNIES EN UNITES	SIND IM UMSCHLAG BEZ	PROVISTO EN GRUPO	
				8000 A1824	8000 A1824	8000 A1824	8000 A1824	8000 A1824	

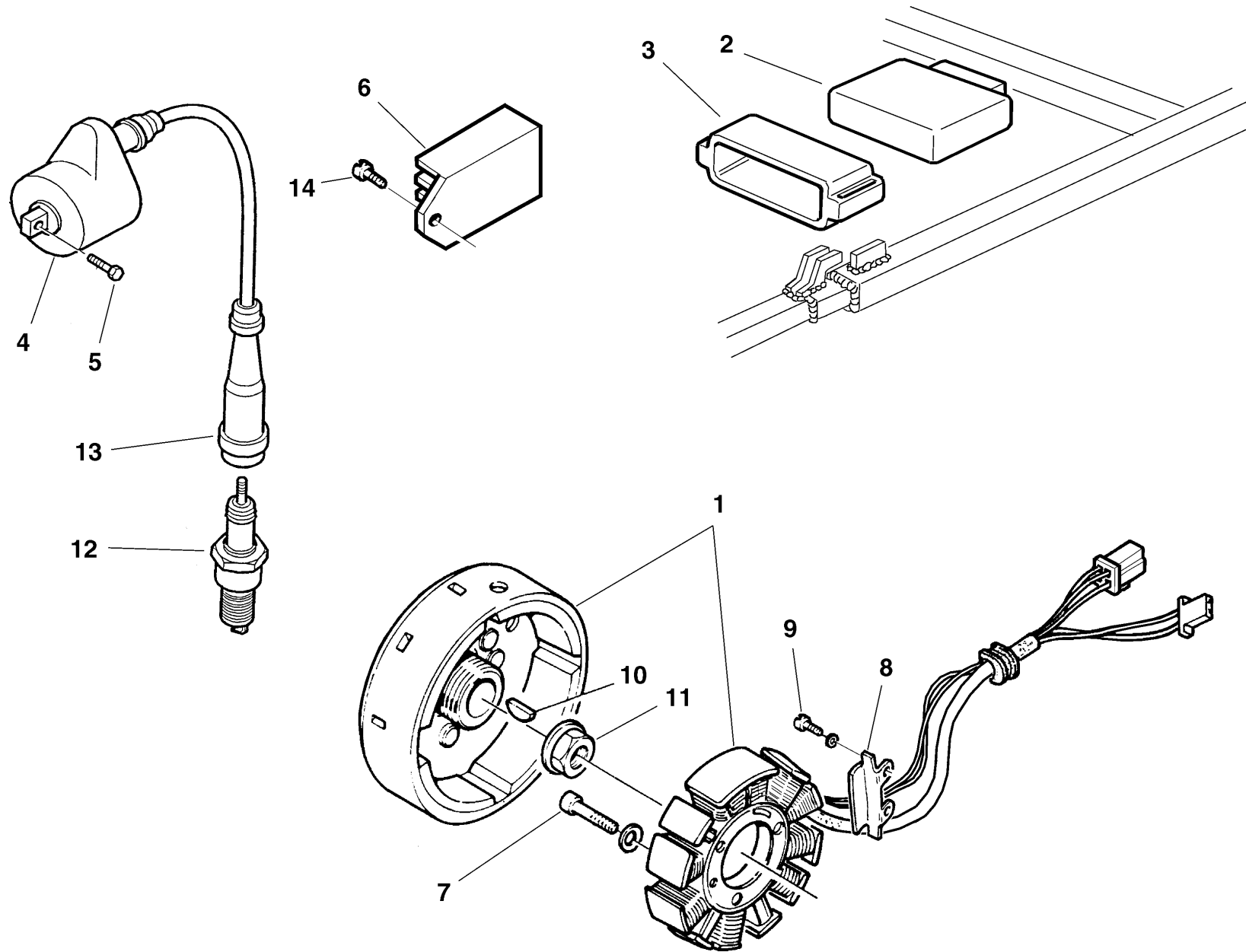



TC-TE 250- 450,  
SM 400R-450R/ 2004

TAVOLA  
DRAWING  
TABLE  
BILD  
TABLA

14

PARTE ELETTRICA - IGNITION SYSTEM  
PARTIES ELECTRIQUE  
ELEKTRISCHE TEILE - PARTE ELECTRICA

Note Notes Markes Notas	Pos. No. N. Index Pos.	N. Cod. Code No. Nr. Code Code Nr N. Cod.	Q.tà Q.ty Q.té M.ge C.ad	DENOMINAZIONE	NAME	DESIGNATION	BESHREIBUNG	DENOMINACION	Validità Validity Validité Gültig Validez
	1	8000 A0571	1	Alternatore compl. (TE 250)	Alternator compl. (TE 250)	Alternateur compl. (TE 250)	Lichtmaschine kpl. (TE 250)	Alternador compl. (TE 250)	
	1	8000 A1430	1	Alternatore compl. (TC 250)	Alternator compl. (TC 250)	Alternateur compl. (TC 250)	Lichtmaschine kpl. (TC 250)	Alternador compl. (TC 250)	
	1	8000 91977	1	Alternatore compl. (400-450)	Alternator compl. (400-450)	Alternateur compl. (400-450)	Lichtmaschine kpl. (400-450)	Alternador compl. (400-450)	
<b>E</b>	2	8000 A0572	1	Centralina elettronica (250)	Electronic device (250)	Dispositif électronique (250)	Zündelectronic (250)	Centralita electrónica (250)	
	2	8000 A1948	1	Centralina elettronica (250)	Electronic device (250)	Dispositif électronique (250)	Zündelectronic (250)	Centralita electrónica (250)	
	2	8A00 91975	1	Centralina elettronica (400-450)	Electronic device (400-450)	Dispositif électronique (400-450)	Zündelectronic (400-450)	Centralita electrónica (400-450)	
	3	8000 91984	1	Supporto elastico	Elastic holder	Support	Halterung	Soporte	
	4	8000 91976	1	Bobina	Coil	Bobine	Zündspule	Bobina	
	5	8000 62727	2	Vite	Screw	Vis	Schraube	Tornillo	
<b>WM</b>	6	8000 91978	1	Regolatore di tensione	Voltage regulator	Régulateur de tension	Spannungsregler	Regulador de tensión	
<b>C</b>	6	8000 A1431	1	Regolatore di tensione	Voltage regulator	Régulateur de tension	Spannungsregler	Regulador de tensión	
<b>WM</b>	7	8000 62728	2	Vite	Screw	Vis	Schraube	Tornillo	
<b>C</b>	7	60N1 02488	2	Vite	Screw	Vis	Schraube	Tornillo	
	8	8000 99868	1	Piastrina	Plate	Plaquette	Plättchen	Placa	
<b>WM</b>	9	8A00 67997	2	Vite	Screw	Vis	Schraube	Tornillo	
<b>C</b>	9	60N1 02483	2	Vite	Screw	Vis	Schraube	Tornillo	
	10	1513 71301	1	Chiavetta	Woodruff key	Clé woodruff	Federkeil	Lengüeta	
	11	8000 A0033	1	Dado	Nut	Ecrou	Mutter	Tuerca	
	12	8000 A0573	1	Candela NGK	Spark plug	Bougie	Zündkerze	Bujía	
	13	8A00 A0129	1	Cappuccio candela	Cap	Capuchon	Kappe	Capuchón	
<b>WM</b>	14	8000 62727	1	Vite	Screw	Vis	Schraube	Tornillo	
<b>C</b>	14	8000 62728	2	Vite	Screw	Vis	Schraube	Tornillo	

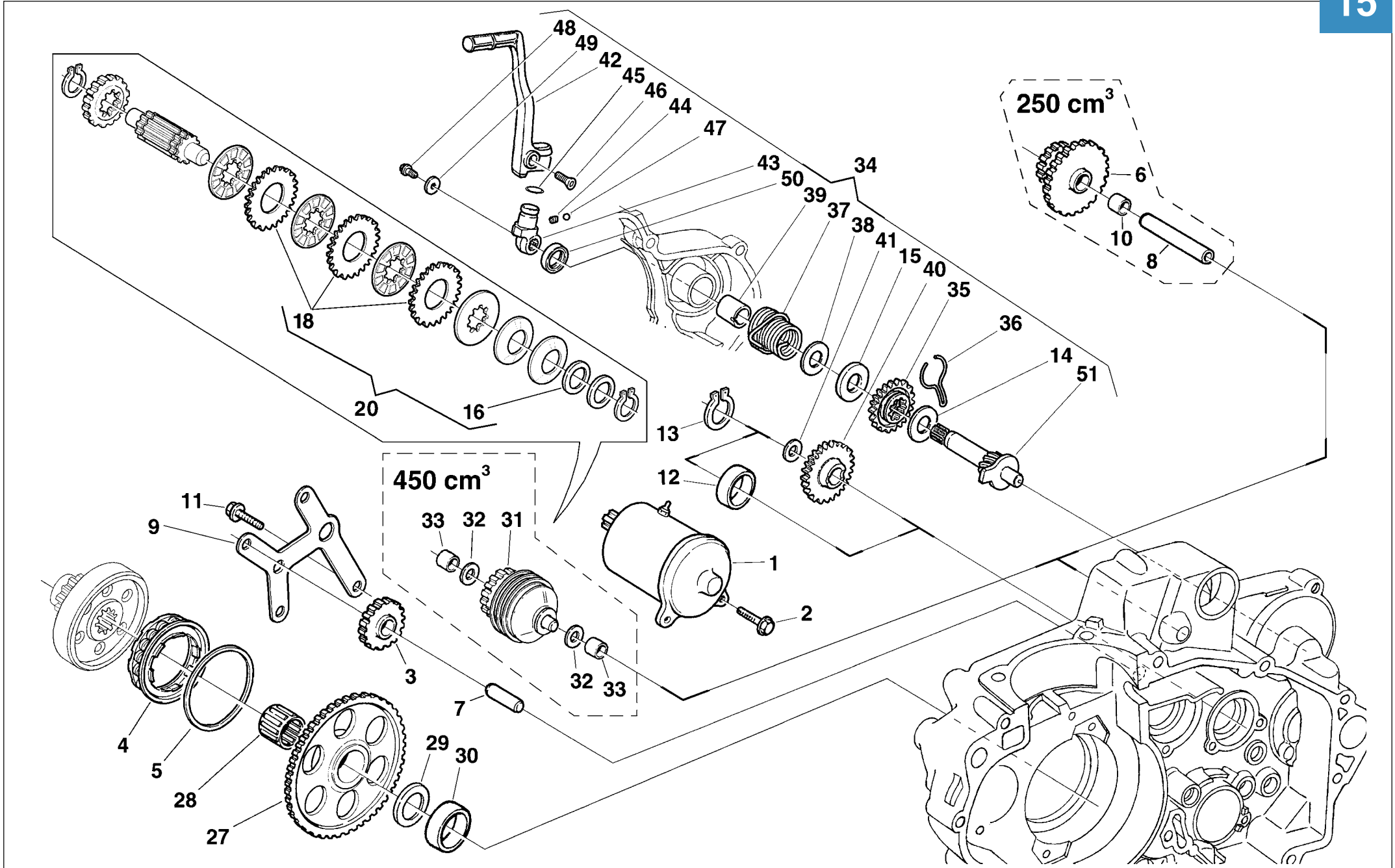





TC-TE 250- 450,  
SM 400R-450R/ 2004

TAVOLA  
DRAWING  
TABLE  
BILD  
TABLA

15

AVVIAMENTO - STARTING  
DEMARRAGE - ANLASSER  
ARRANQUE

Note Notes Notes Marka Notas	Pos. No. N. Index Pos.	N. Cod. Code No. Nr. Code Code Nr N. Cod.	Q.tà Q.ty Q.te M.ge C.ad	DENOMINAZIONE	NAME	DESIGNATION	BESHREIBUNG	DENOMINACION	Validità Validity Validité Gültig Validez
	1	8000 97943	1	Ass. motorino avviamento	El. start motor	Moteur démarr. el.	Elektr Anlasser	Motor de arranque	
	2	8000 62729	2	Vite	Screw	Vis	Schraube	Tornillo	
	3	8000 99958	1	Ingran. di rinvio (Z =24)	Gear 2nd transmission (Z =24)	Engrenage (Z =24)	Zahnrad (Z =24)	Engrenaje (Z =24)	
	4	8A00 87289	1	Ruota libera (250)	Free wheel (250)	Roue libre (250)	Freilauf (250)	Rueda libre (250)	
	4	8000 A0709	1	Ruota libera (400-450)	Free wheel (400-450)	Roue libre (400-450)	Freilauf (400-450)	Rueda libre (400-450)	
	5	8000 86732	1	Disco ritegno (250)	Disc (250)	Disque (250)	Scheibe (250)	Disco (250)	
	5	8000 A0710	1	Disco ritegno (400-450)	Disc (400-450)	Disque (400-450)	Scheibe (400-450)	Disco (400-450)	
	6	8000 99959	1	Ingran. di rinvio (Z =60/21)	Gear 2nd transmission (Z =60/21) (250)	Engrenage (Z =60/21) (250)	Zahnrad (Z =60/21) (250)	Engrenaje (Z =60/21) (250)	
	7	8000 99960	1	Perno	Pin	Pivot	Bolzen	Perno	
	8	8000 A1011	1	Perno (250)	Pin (250)	Pivot (250)	Bolzen (250)	Perno (250)	
	9	8000 A1022	1	Piastra	Plate	Plaquette	Plättchen	Placa	
	10	8000 A1216	1	Distanziale (250)	Spacer (250)	Entretoise (250)	Distanzstück (250)	Separador (250)	
	11	8000 62727	4	Vite	Screw	Vis	Schraube	Tornillo	
	12	8000 A0746	1	Distanziale	Spacer	Entretoise	Distanzstück	Separador	
	13	66N0 21208	1	Anello elastico	Split ring	Anneau ressort	Sprengring	Anillo elástico	
<b>D</b>	14	8D00 36022	1	Rosetta	Washer	Rondelle	Scheibe	Arandela	
<b>D</b>	15	8B00 65503	1	Rosetta	Washer	Rondelle	Scheibe	Arandela	
<b>N</b>	16	8C00 48590	1	Rosetta	Washer	Rondelle	Scheibe	Arandela	
<b>N</b>	18	8000 A4287	3	Disco dentato	Disc	Disque	Platte	Disco	
	20	8000 A4337	1	Kit frizione avviamento (400-450)	Starting clutch KIT (400-450)	Kit embrajage demarrage (400-450)	Anlasser Kupplungsgruppe (400-450)	Kit embrague arranque (400-450)	
	27	8000 99956	1	Corona per ruota libera (Z =70) (250)	Ring gear (Z =70) (250)	Couronne (Z =70) (250)	Kranz (Z =70) (250)	Corona (Z =70) (250)	
	27	8000 A0739	1	Corona per ruota libera (Z =70) (400-450)	Ring gear (Z =70) (400-450)	Couronne (Z =70) (400-450)	Kranz (Z =70) (400-450)	Corona (Z =70) (400-450)	
	28	8000 35763	1	Gabbia a rullini (ø28xø33x17 mm)	Needle cage (ø28xø33x17 mm)	Cage à aiguilles (ø28xø33x17 mm)	Nadelkaefig (ø28xø33x17 mm)	Casquillo(ø28xø33x17 mm)	
	29	8A00 84473	1	Rosetta di rasamento	Washer	Rondelle	Scheibe	Arandela	
	30	8000 99957	1	Distanziale	Spacer	Entretoise	Distanzstück	Separador	
	31	8000 A1279	1	Frizione avviamento elettrico (400-450)	Electric start clutch (400-450)	Embraiage demarrage (400-450)	Anlasser kupplung (400-450)	Embrague arranque (400-450)	

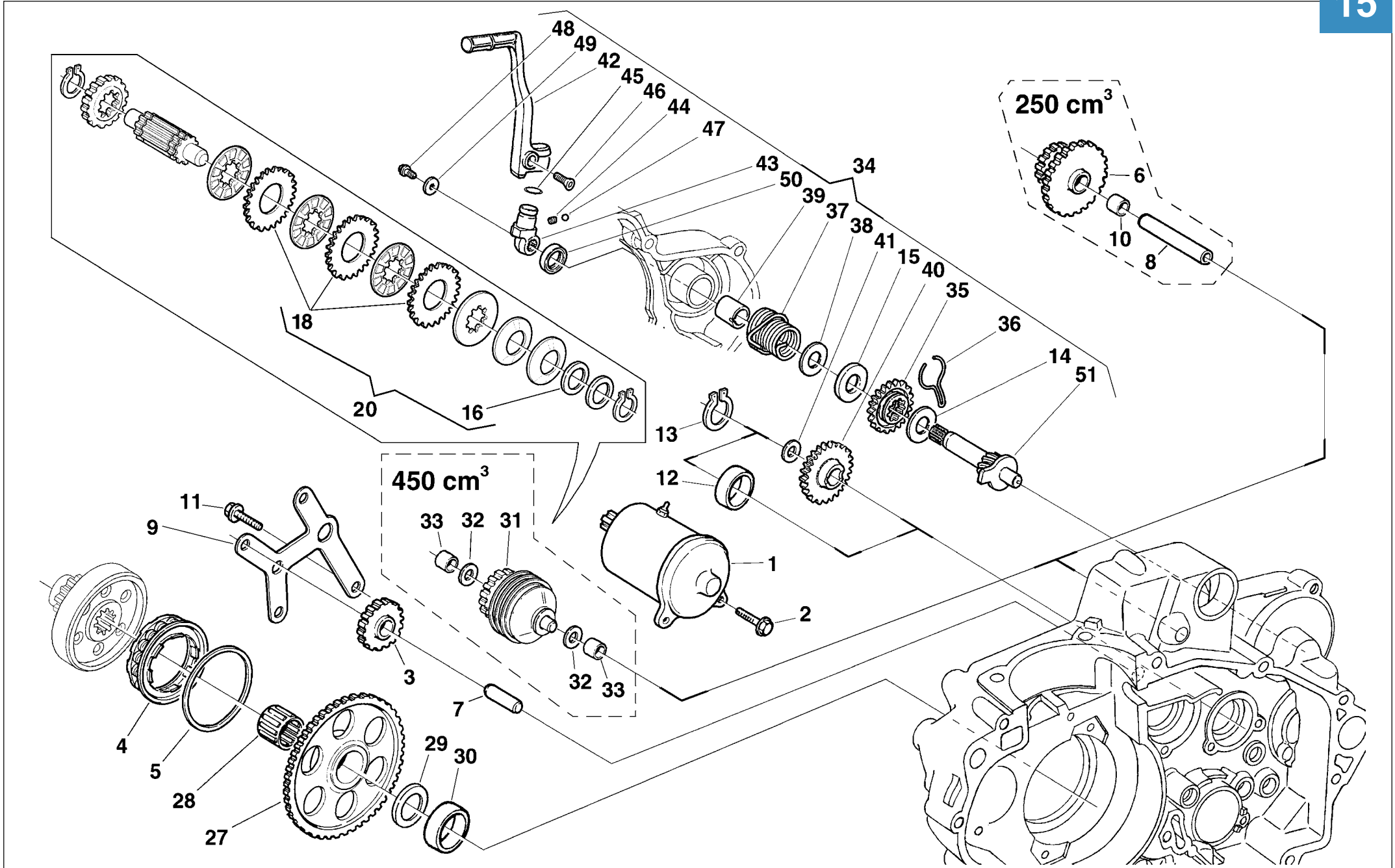



**TC-TE 250- 450,  
SM 400R-450R/ 2004**

TAVOLA  
DRAWING  
TABLE  
BILD  
TABLA

**15**

**AVVIAMENTO - STARTING  
DEMARRAGE - ANLASSER  
ARRANQUE**

Note Notes Marke Notas	Pos. No. Index Pos.	N. Cod. Code No. Nr. Code Code Nr N. Cod.	Q.tà Q.ty Q.te M.ge C.ad	DENOMINAZIONE	NAME	DESIGNATION	BESHREIBUNG	DENOMINACION	Validità Validity Validité Gültig Validez
	32	8000 05876	2	Rosetta (400-450)	Washer (400-450)	Rondelle (400-450)	Scheibe (400-450)	Arandela (400-450)	
	33	8000 A1017	2	Bussola (400-450)	Bushing (400-450)	Douille (400-450)	Buchse (400-450)	Manguito (400-450)	
<b>D</b>	34	8000 A3016	1	Kit avviamento a pedale	Kick starter kit	Démarrage à pedale	Anlasser mit Kickstarter	Arranque a pedal	
<b>D</b>	35	8000 99964	1	Ingranaggio scorrevole (Z=28)	Gear (Z=28)	Engrenage (Z=28)	Zahnr. (Z=28)	Engranaje (Z=28)	
<b>D</b>	36	8A00 67016	1	Molla frizione	Clutch spring	Ressort embrayage	Kupplungsfeder	Resorte embrague	
<b>D</b>	37	8000 99965	1	Molla rich. leva avviamento	Spring	Ressort	Feder	Resorte	
<b>D</b>	38	8E00 18282	1	Rosetta	Washer	Rondelle	Scheibe	Arandela	
<b>D</b>	39	8000 A3017	1	Distanziale	Spacer	Entretoise	Distanzstück	Separador	
<b>D</b>	40	8000 99966	1	Ingranaggio di rinvio (Z=30)	Gear (Z=30)	Engrenage (Z=30)	Zahnr. (Z=30)	Engranaje (Z=30)	
<b>D</b>	41	8B00 07989	1	Rosetta	Washer	Rondelle	Scheibe	Arandela	
<b>D</b>	42	8000 99971	1	Pedale avviamento	Pedal	Pedale	Pedal	Pedal	
<b>D</b>	43	8000 99972	1	Mozzetto	Hub	Moyeau	Radnabe	Cubo	
<b>D</b>	44	8000 A4571	1	Molla	Spring	Ressort	Feder	Resorte	
<b>D</b>	45	8000 36380	1	Anello OR	O-Ring	Bague OR	O-Ring	Anillo OR	
<b>D</b>	46	8000 38287	1	Vite	Screw	Vis	Schraube	Tornillo	
<b>D</b>	47	6BN0 21506	1	Sfera (7/32")	Ball (7/32")	Bille (7/32")	Kugel (7/32")	Esfera (7/32")	
<b>D</b>	48	8000 60577	1	Vite	Screw	Vis	Schraube	Tornillo	
<b>D</b>	49	8000 99973	1	Rosetta	Washer	Rondelle	Scheibe	Arandela	
<b>D</b>	50	8000 36653	1	Anello di tenuta (ø16x25x4 mm)	Seal ring (ø16x25x4 mm)	Bague d'étanchéité (ø16x25x4 mm)	Dichtungsring (ø16x25x4 mm)	Anillo de retención (ø16x25x4 mm)	
<b>D</b>	51	8000 99962	1	Albero avviamento	Starter crank shaft	Arbre de démarrage	Kickstarterwelle	Eje arranque	

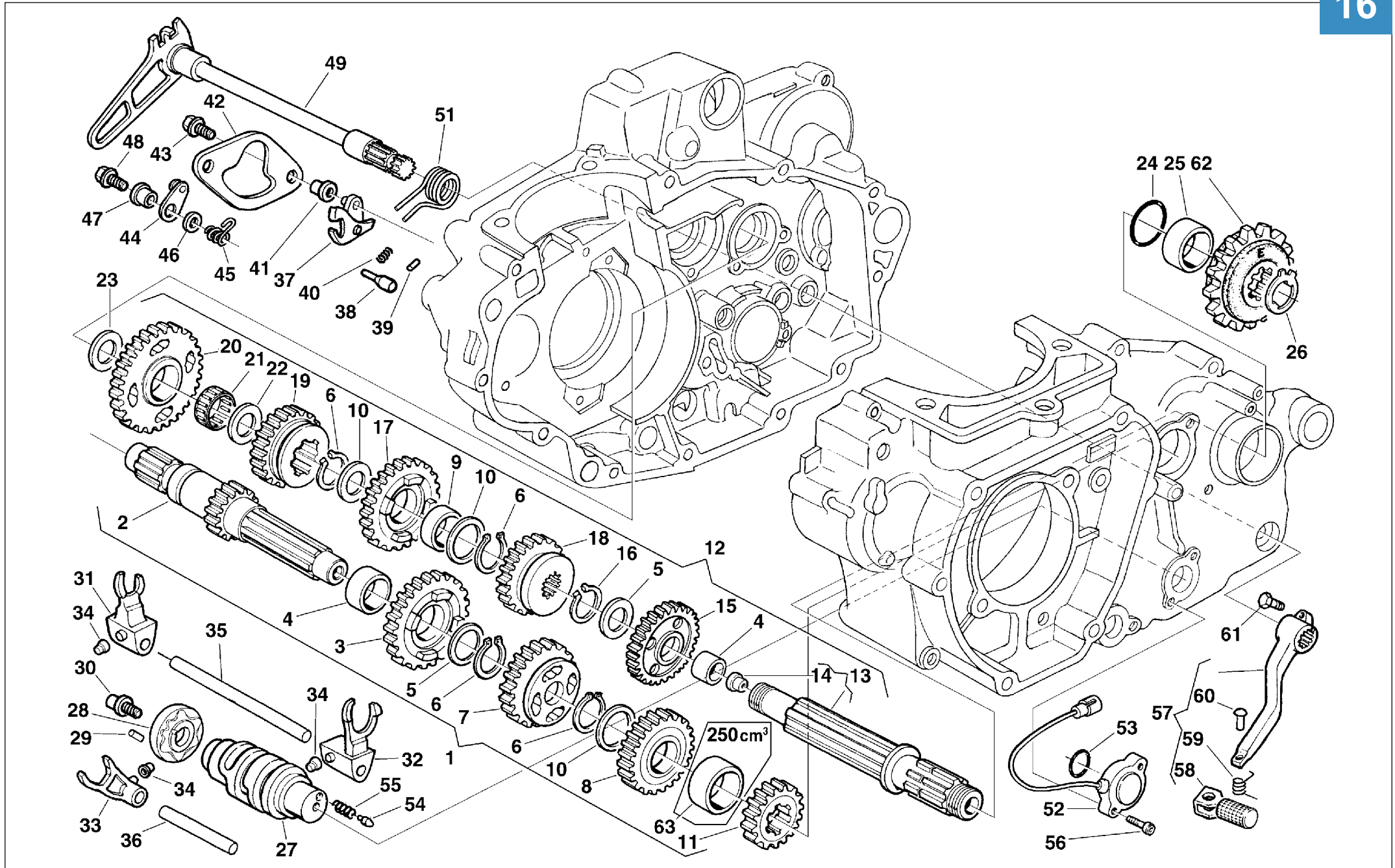

Note Notes Marka Notas	Pos. No. N. Index Pos.	N. Cod. Code No. Nr. Code Code Nr N. Cod.	Q.tà Q.ty M.ge C.ad	DENOMINAZIONE	NAME	DESIGNATION	BESCHREIBUNG	DENOMINACION	Validità Validity Validité Gültig Validez
	1	8000 A1322	1	Albero primario completo (TC 250)	Main shaft (TC 250)	Arbre primaire (TC 250)	Hauptwelle (TC 250)	Eje principal completo (TC 250)	
	1	8000 99780	1	Albero primario completo (TC 450)	Main shaft (TC 450)	Arbre primaire (TC 450)	Hauptwelle (TC 450)	Eje principal completo (TC 450)	
	2	8000 A1323	1	Albero primario (Z=15) (TC 250)	Main shaft (Z=15) (TC 250)	Arbre primaire (Z=15) (TC 250)	Hauptwelle (Z=15) (TC 250)	Eje primario (Z=15) (TC 250)	
	2	8000 99781	1	Albero primario (Z=15) (TC 450)	Main shaft (Z=15) (TC 450)	Arbre primaire (Z=15) (TC 450)	Hauptwelle (Z=15) (TC 450)	Eje primario (Z=15) (TC 450)	
	3	8000 A1324	1	Ingran. 5ª A.P. (Z=22) (TC 250)	Gear speed (Z=22) (TC 250)	Engrenage 5ème (Z=22) (TC 250)	Zahnrad 5.Gang (Z=22) (TC 250)	Engranaje 5º velocidad (Z=22) (TC 250)	
	3	8000 99782	1	Ingran. 5ª A.P. (Z=22) (TC 450)	Gear speed (Z=22) (TC 450)	Engrenage 5ème (Z=22) (TC 450)	Zahnrad 5.Gang (Z=22) (TC 450)	Engranaje 5º velocidad (Z=22) (TC 450)	
	4	8000 63822	2	Bussola	Bushing	Douille	Buchse	Manguito	
	5	8D00 36022	2	Rosetta	Washer	Rondelle	Scheibe	Arandela	
	6	8000 31772	4	Anello di fermo	Stop ring	Bague d'arrêt	Haltering	Anillo de retención	
	7	8000 A1325	1	Ingranaggio 3ª A.P. (Z=19) (TC 250)	Main shaft 3rd gear (Z=19) (TC 250)	Engrenage 3ème vitesse A.P. (Z=19) (TC 250)	Zahnr. f. 3. Geschw. Antriebsw. (Z=19) (TC 250)	Engranaje 3º velocidad Eje P. (Z=19) (TC 250)	
	7	8000 99783	1	Ingranaggio 3ª A.P. (Z=19) (TC 450)	Main shaft 3rd gear (Z=19) (TC 450)	Engrenage 3ème vitesse A.P. (Z=19) (TC 450)	Zahnr. f. 3. Geschw. Antriebsw. (Z=19) (TC 450)	Engranaje 3º velocidad Eje P. (Z=19) (TC 450)	
	8	8000 A1326	1	Ingranaggio 4ª A.P. (Z=23) (TC 250)	Main shaft 4th gear (Z=23) (TC 250)	Engrenage 4ème vitesse A.P. (Z=23) (TC 250)	Zahnr. f. 4. Geschw. Antriebsw. (Z=23) (TC 250)	Engranaje 4º velocidad Eje P. (Z=23) (TC 250)	
	8	8000 99784	1	Ingranaggio 4ª A.P. (Z=23) (TC 450)	Main shaft 4th gear (Z=23) (TC 450)	Engrenage 4ème vitesse A.P. (Z=23) (TC 450)	Zahnr. f. 4. Geschw. Antriebsw. (Z=23) (TC 450)	Engranaje 4º velocidad Eje P. (Z=23) (TC 450)	
	9	8000 63821	2	Bussola	Bushing	Douille	Buchse	Manguito	
	10	8000 88255	3	Rosetta di rasamento	Washer	Rondelle	Scheibe	Arandela	
	11	8000 A1327	1	Ingranaggio 2ª A.P. (Z=17) (TC 250)	Main shaft 2nd gear (Z=17) (TC 250)	Engrenage 2ème vitesse A.P. (Z=17) (TC 250)	Zahnr. f. 2. Geschw. Antriebsw. (Z=17) (TC 250)	Engranaje 2º velocidad Eje P. (Z=17) (TC 250)	
	11	8000 99785	1	Ingranaggio 2ª A.P. (Z=17) (TC 450)	Main shaft 2nd gear (Z=17) (TC 450)	Engrenage 2ème vitesse A.P. (Z=17) (TC 450)	Zahnr. f. 2. Geschw. Antriebsw. (Z=17) (TC 450)	Engranaje 2º velocidad Eje P. (Z=17) (TC 450)	
	12	8000 A1329	1	Albero secondario completo (TC 250)	Layshaft compl. (TC 250)	Arbre secondaire compl. (TC 250)	Vorgelegewelle kpl. (TC 250)	Eje secundario completo (TC 250)	
	12	8000 A1926	1	Albero secondario completo (TC 450)	Layshaft compl. (TC 450)	Arbre secondaire compl. (TC 450)	Vorgelegewelle kpl. (TC 450)	Eje secundario completo (TC 450)	



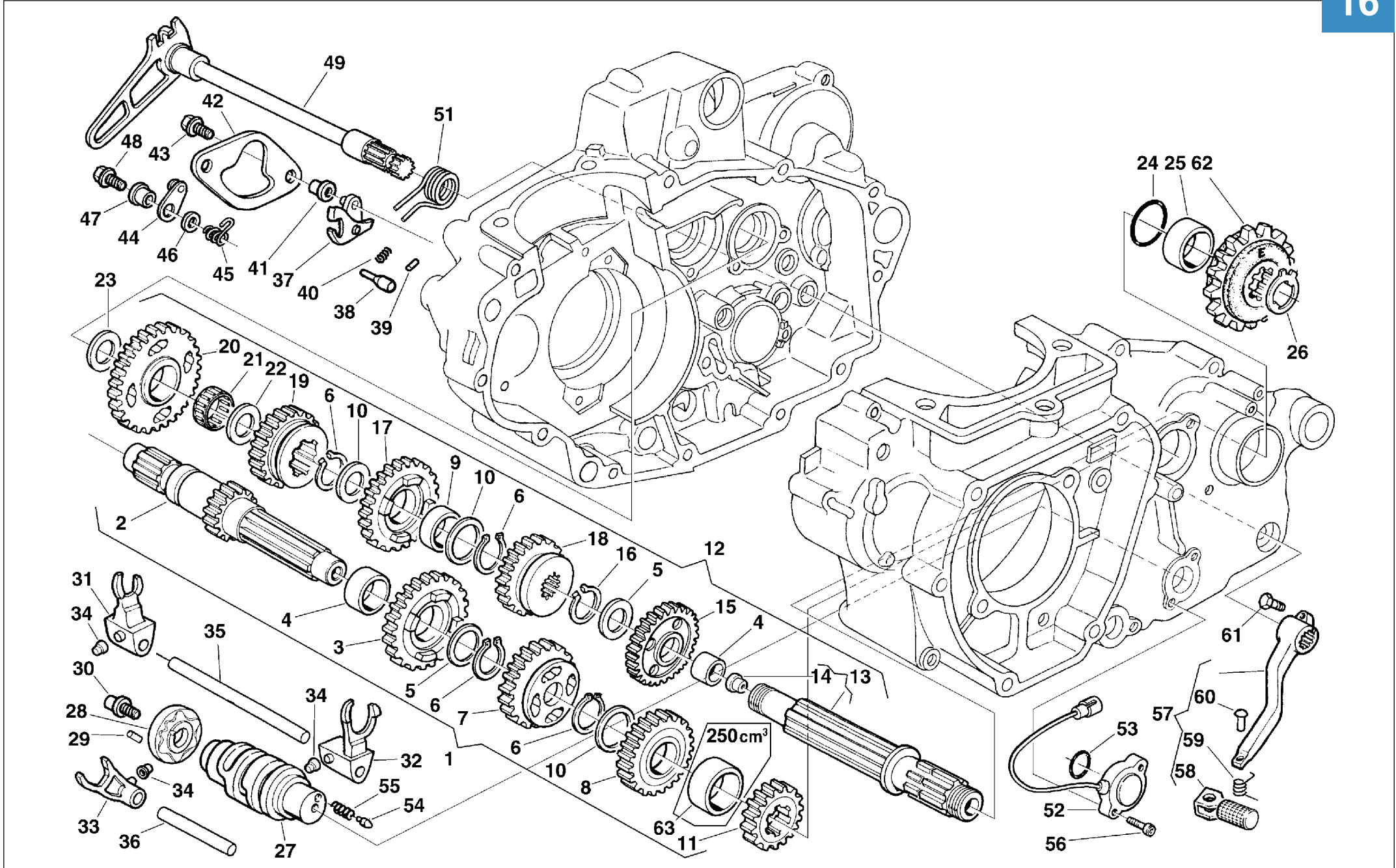



Note Notes Notas	Pos. No. Index Pos.	N. Cod. Code No. Nr. Code Code Nr N. Cod.	Q.tà Q.ty M.ge C.ad	DENOMINAZIONE	NAME	DESIGNATION	BESHREIBUNG	DENOMINACION	Validità Validity Validité Gültig Validez
	13	8000 A1330	1	Albero secondario (TC 250)	Layshaft (TC 250)	Arbre secondaire (TC 250)	Vorgelegewelle (TC 250)	Eje secundario (TC 250)	
	13	8000 99787	1	Albero secondario (TC 450)	Layshaft (TC 450)	Arbre secondaire (TC 450)	Vorgelegewelle (TC 450)	Eje secundario (TC 450)	
	14	8000 57196	1	Tappo	Plug	Bouchon	Verschluss	Tapón	
	15	8000 A1332	1	Ingranaggio 2ª A.S. (Z=26) (TC 250)	Secondary shaft 2nd gear (Z=26) (TC 250)	Engrenage 2ème vitesse A.S. (Z=26) (TC 250)	Zah. f. 2. Geschw. Vorgelegew. (Z=26) (TC 250)	Engranaje 2º velocidad Eje S. (Z=26) (TC 250)	
	15	8000 A1913	1	Ingranaggio 2ª A.S. (Z=26) (TC 450)	Secondary shaft 2nd gear (Z=26) (TC 450)	Engrenage 2ème vitesse A.S. (Z=26) (TC 450)	Zah. f. 2. Geschw. Vorgelegew. (Z=26) (TC 450)	Engranaje 2º velocidad Eje S. (Z=26) (TC 450)	
	16	66N0 21211	3	Anello di fermo	Stop ring	Bague d'arrêt	Haltering	Anillo de retención	
	17	8000 A1333	1	Ingranaggio 3ª A.S. (Z=24) (TC 250)	Secondary shaft 3rd gear (Z=24) (TC 250)	Engrenage 3ème vitesse A.S. (Z=24) (TC 250)	Zah. f. 3. Geschw. Vorgelegew. (Z=24) (TC 250)	Engranaje 3º velocidad Eje S. (Z=24) (TC 250)	
	17	8000 99790	1	Ingranaggio 3ª A.S. (Z=24) (TC 450)	Secondary shaft 3rd gear (Z=24) (TC 450)	Engrenage 3ème vitesse A.S. (Z=24) (TC 450)	Zah. f. 3. Geschw. Vorgelegew. (Z=24) (TC 450)	Engranaje 3º velocidad Eje S. (Z=24) (TC 450)	
	18	8000 A1334	1	Ingranaggio 4ª A.S. (Z=25) (TC 250)	Secondary shaft 4th gear (Z=25) (TC 250)	Engrenage 4ème vitesse A.S. (Z=25) (TC 250)	Zah. f. 4. Geschw. Vorgelegew. (Z=25) (TC 250)	Engranaje 4º velocidad Eje S. (Z=25) (TC 250)	
	18	8000 A1914	1	Ingranaggio 4ª A.S. (Z=25) (TC 450)	Secondary shaft 4th gear (Z=25) (TC 450)	Engrenage 4ème vitesse A.S. (Z=25) (TC 450)	Zah. f. 4. Geschw. Vorgelegew. (Z=25) (TC 450)	Engranaje 4º velocidad Eje S. (Z=25) (TC 450)	
	19	8000 A1335	1	Ingranaggio 5ª A.S. (Z=21) (TC 250)	Secondary shaft 5th gear (Z=21) (TC 250)	Engrenage 5ème vitesse A.S. (Z=21) (TC 250)	Zah. f. 5. Geschw. Vorgelegew. (Z=21) (TC 250)	Engranaje 5º velocidad Eje S. (Z=21) (TC 250)	
	19	8000 A1915	1	Ingranaggio 5ª A.S. (Z=21) (TC 450)	Secondary shaft 5th gear (Z=21) (TC 450)	Engrenage 5ème vitesse A.S. (Z=21) (TC 450)	Zah. f. 5. Geschw. Vorgelegew. (Z=21) (TC 450)	Engranaje 5º velocidad Eje S. (Z=21) (TC 450)	
	20	8000 A1336	1	Ingranaggio 1ª A.S. (Z=28) (TC 250)	Gear 1st speed (Z=28) (TC 250)	Engrenage 1ère (Z=28) (TC 250)	Zahnrad 1. Gang (Z=28) (TC 250)	Engranaje 1º velocidad (Z=28) (TC 250)	
	20	8000 A1916	1	Ingranaggio 1ª A.S. (Z=28) (TC 450)	Gear 1st speed (Z=28) (TC 450)	Engrenage 1ère (Z=28) (TC 450)	Zahnrad 1. Gang (Z=28) (TC 450)	Engranaje 1º velocidad (Z=28) (TC 450)	
	21	8000 22373	1	Gabbia a rullini (ø20xø24x10 mm)	Needle cage (ø20xø24x10 mm)	Cage à aiguilles (ø20xø24x10 mm)	Nadelkaefig (ø20xø24x10 mm)	Casquillo(ø20xø24x10 mm)	
	22	8G00 07989	1	Rosetta	Washer	Rondelle	Scheibe	Arandela	
	23	8G00 07989	1	Rosetta	Washer	Rondelle	Scheibe	Arandela	
	24	8000 41693	1	Anello OR	O-Ring	Bague OR	O-Ring	Anillo OR	
	25	8000 86953	1	Distanziale	Spacer	Entretoise	Distanzstück	Separador	
	26	66N0 21211	1	Anello di fermo	Stop ring	Bague d'arrêt	Haltering	Anillo de retención	

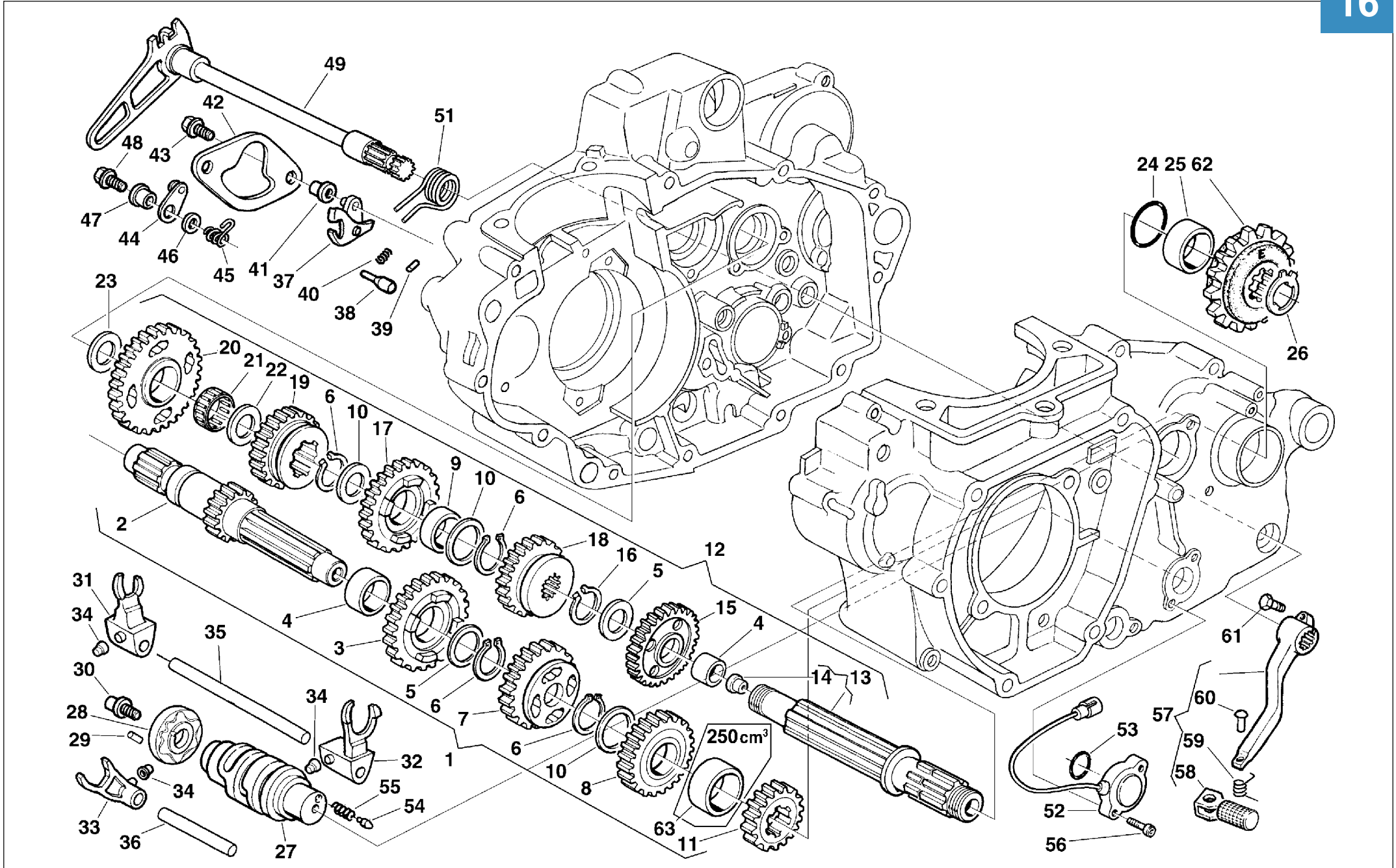



TC 250-450/2004

TAVOLA  
DRAWING  
TABLE  
BILD  
TABLA

16

CAMBIO, COMANDO CAMBIO - TRANSMISSION, SHIFTER  
BOITE DE VITESSE, COMMANDE DE VITESSE  
WECHSELGETRIEBE, GANGSCHALTUNG - CAMBIO, MANDO CAMBIO

5 SPEED

Note Notes Notas	Pos. No. Index Pos.	N. Cod. Code No. Nr. Code Code Nr N. Cod.	Q.tà Q.ty Q.te M.ge C.ad	DENOMINAZIONE	NAME	DESIGNATION	BESHREIBUNG	DENOMINACION	Validità Validity Validité Gültig Validez
	27	8000 99919	1	Albero forcelle cambio	Driving shaft gearbox forks	Arbre comm. fourches trans.	Antriebswelle Schaltgabel	Eje mando horquilla cambio	
	28	8A00 97739	1	Tamburo selettore marce	Drum	Tambour	Trommel	T%ambor	
	29	8000 38520	1	Rullino	Roller	Aiguille	Rolle	Rodillo	
	30	8000 98149	1	Vite	Screw	Vis	Schraube	Tornillo	
	31	8000 A0091	1	Forcella cambio (1ª)	Fork (1st)	Fourche (1ère)	Gabel (1)	Horquilla (1° )	
	32	8000 A0092	1	Forcella cambio (2ª-3ª)	Fork (2nd-3rd)	Fourche (2ème-3ème)	Gabel (2-3)	Horquilla (2°-3° )	
	33	8000 99738	1	Forcella cambio (5ª)	Fork (5th)	Fourche (5ème)	Gabel (5)	Horquilla (5°)	
	34	8000 71010	3	Rotella	Disc	Disque	Scheibe	Disco	
	35	8000 38711	1	Perno (L=96 mm)	Pin (L=96 mm)	Pivot (L=96 mm)	Bolzen (L=96 mm)	Perno (L=96 mm)	
	36	8000 38712	1	Perno (L=57 mm)	Pin (L=57 mm)	Pivot (L=57 mm)	Bolzen (L=57 mm)	Perno (L=57 mm)	
	37	8000 87299	1	Rocchetto selettore dentato	Sprocket	Rochet	Spule	Piñon	
	38	8000 71007	2	Saltarello per rocchetto	Click	Cliquet	Strumhaken	Salt.	
	39	8000 71008	2	Puntale per saltarello	Push rod	Embout	Stösselschaft	Puntal	
	40	8000 71009	2	Molla	Spring	Ressort	Feder	Resorte	
	41	8000 71010	1	Rotella	Disc	Disque	Scheibe	Disco	
	42	8000 99739	1	Piastrina	Plate	Plaque	Platte	Placa	
	43	8000 62726	2	Vite	Screw	Vis	Schraube	Tornillo	
	44	8000 85495	1	Saltarello fissamarce	Click	Cliquet	Strumhaken	Salt.	
	45	8000 A1748	1	Molla	Spring	Ressort	Feder	Resorte	
	46	8000 86107	1	Rosetta di rasamento	Washer	Rondelle	Scheibe	Arandela	
	47	8000 85493	1	Bussola	Bushing	Douille	Buchse	Manguito	
	48	8000 62726	1	Vite	Screw	Vis	Schraube	Tornillo	
	49	8000 91559	1	Albero com. selettore	Gearbox pedal shaft assy	Arbre péd. change vit. compl.	Umsteuerungswelle kpl.	Eje pedal cambio compl.	
	51	8000 72826	1	Molla	Spring	Ressort	Feder	Resorte	
	52	8000 A0579	1	Segnalatore folle	Idle trasponder assy	Signaleur point mort compl.	Leerlauflicht kpl.	Señalador compl.	
	53	8A00 42700	1	Anello OR	O-Ring	Bague OR	O-Ring	Anillo OR	
	54	8000 42676	1	Puntale per segnalatore marce	Push rod	Embout	Stösselschaft	Puntal	
	55	8000 42677	1	Molla	Spring	Ressort	Feder	Resorte	
	56	8000 66525	2	Vite	Screw	Vis	Schraube	Tornillo	
E	57	8000 99741	1	Leva comando cambio	Gearchange lever assy	Levier comm. vitesse compl.	Schalthebel kpl.	Palanca del cambio compl.	
	57	8000 A3488	1	Leva comando cambio	Gearchange lever assy	Levier comm. vitesse compl.	Schalthebel kpl.	Palanca del cambio compl.	
E	58	8000 A3485	1	Pedale leva comando cambio	Gearchange lever pedal	Pedale	Pedal	Pedal	
	58	8A00 A3485	1	Pedale leva comando cambio	Gearchange lever pedal	Pedale	Pedal	Pedal	

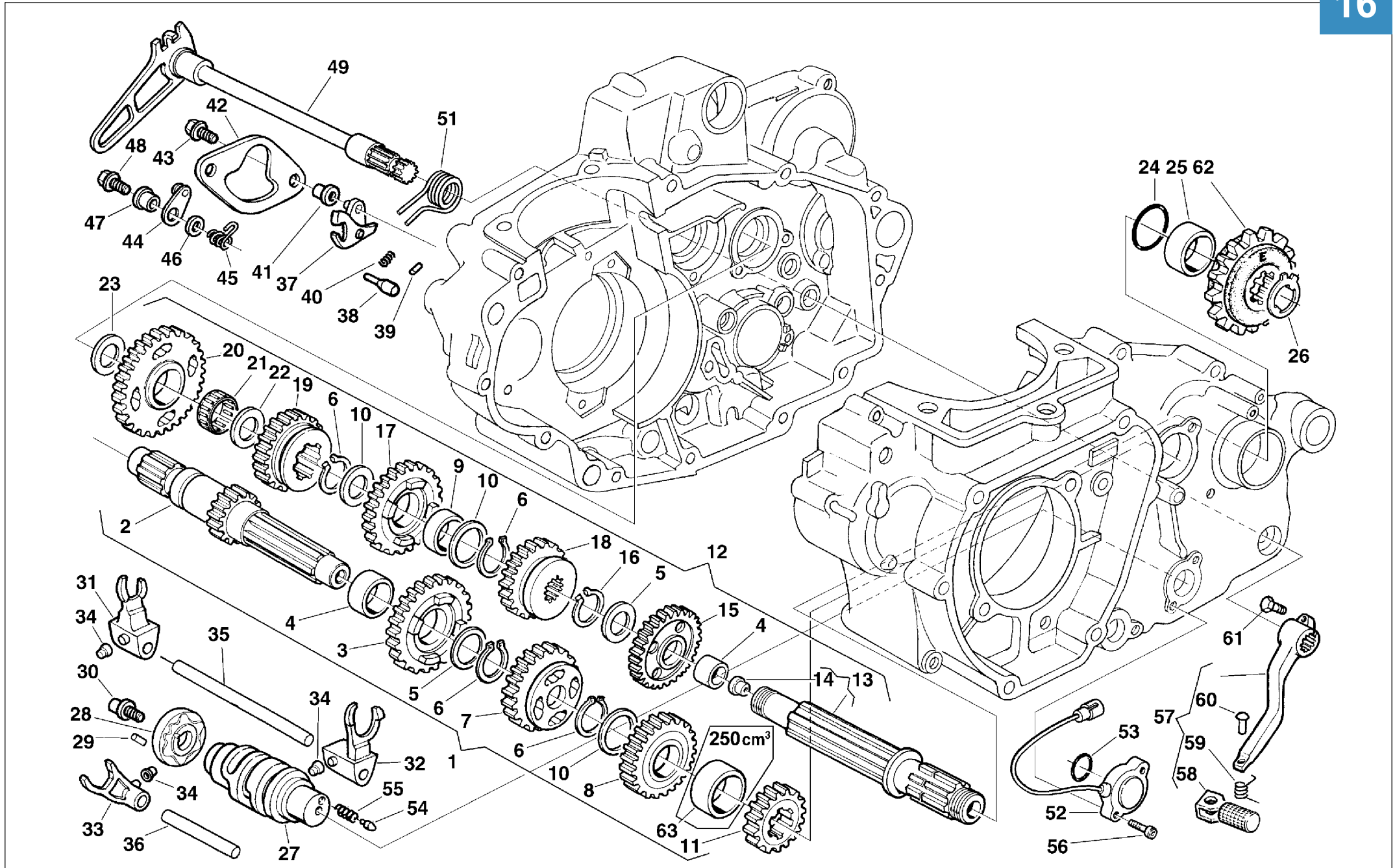



TC 250-450/2004

TAVOLA  
DRAWING  
TABLE  
BILD  
TABLA

16

CAMBIO, COMANDO CAMBIO - TRANSMISSION, SHIFTER  
BOITE DE VITESSE, COMMANDE DE VITESSE  
WECHSELGETRIEBE, GANGSCHALTUNG - CAMBIO, MANDO CAMBIO

5 SPEED

Note Notes Markes Notas	Pos. No. N. Index Pos.	N. Cod. Code No. Nr. Code Code Nr N. Cod.	Q.tà Q.ty Q.té M.ge C.ad	DENOMINAZIONE	NAME	DESIGNATION	BESHREIBUNG	DENOMINACION	Validità Validity Validité Gültig Validez
	59	8000 70216	1	Molla	Spring	Ressort	Feder	Resorte	
	60	8000 99744	1	Ribattino	Rivet	Rivet	Niet	Remache	
	61	8000 62728	1	Vite	Screw	Vis	Schraube	Tornillo	
<b>R</b>	62	8000 63827	1	Pignone Z=12	Pinion Z=12	Pignon Z=12	Ritzel Z=12	Piñón Z=12	
<b>R</b>	62	8000 63828	1	Pignone Z=13 (TC 250)	Pinion Z=13 (TC 250)	Pignon Z=13 (TC 250)	Ritzel Z=13 (TC 250)	Piñón Z=13 (TC 250)	
<b>R</b>	62	8000 63829	1	Pignone Z=14 (TC 250)	Pinion Z=14 (TC 250)	Pignon Z=14 (TC 250)	Ritzel Z=14 (TC 250)	Piñón Z=14 (TC 250)	
<b>R</b>	62	8000 63830	1	Pignone Z=15 (TC 450)	Pinion Z=15 (TC 450)	Pignon Z=15 (TC 450)	Ritzel Z=15 (TC 450)	Piñón Z=15 (TC 450)	
<b>RY</b>	62	8000 63831	1	Pignone Z=16	Pinion Z=16	Pignon Z=16	Ritzel Z=16	Piñón Z=16	
	63	8000 A1328	1	Distanziale (TC 250)	Spacer (TC 250)	Entretoise (TC 250)	Distanzstück (TC 250)	Separador (TC 250)	



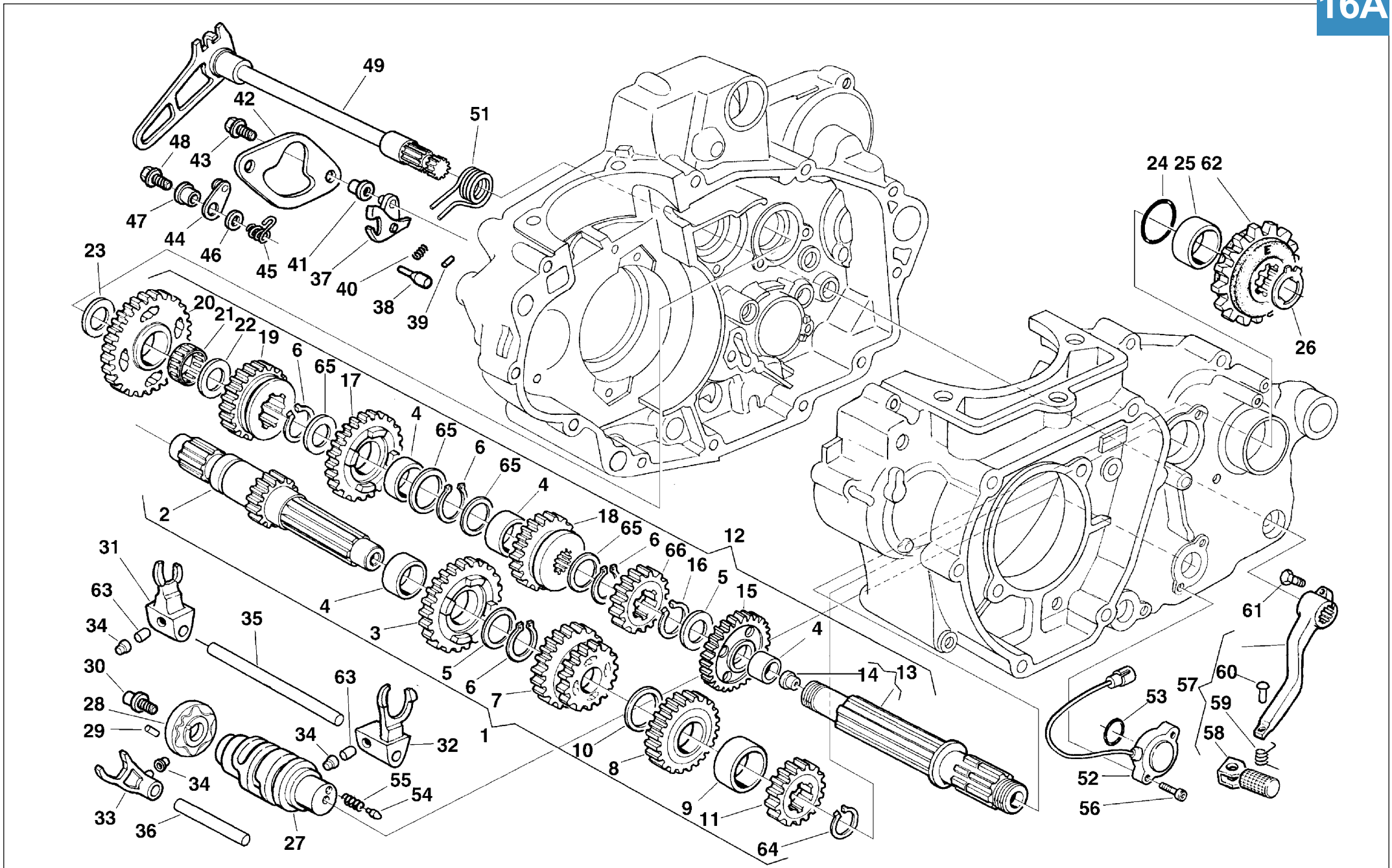





TE 250- 450,  
SM 400R-450R/ 2004

TAVOLA  
DRAWING  
TABLE  
BILD  
TABLA

16A

CAMBIO, COMANDO CAMBIO - TRANSMISSION, SHIFTER  
BOITE DE VITESSE, COMMANDE DE VITESSE  
WECHSELGETRIEBE, GANGSCHALTUNG - CAMBIO, MANDO CAMBIO

6 SPEED

Note Notes Notas	Pos. No. Index Pos.	N. Cod. Code No. Nr. Code Code Nr N. Cod.	Q.tà Q.ty Q.te M.ge C.ad	DENOMINAZIONE	NAME	DESIGNATION	BESHREIBUNG	DENOMINACION	Validità Validity Validité Gültig Validez
	1	8000 A1299	1	Albero primario completo	Main shaft	Arbre primaire	Hauptwelle	Eje principal completo	
	2	8000 A1300	1	Albero primario (Z=14)	Main shaft (Z=14)	Arbre primaire (Z=14)	Hauptwelle (Z=14)	Eje primario (Z=14)	
	3	8000 88244	1	Ingran. 5ª A.P. (Z=25)	Gear 5th - 6th speed (Z=25)	Engrenage 5ème (Z=25)	Zahnrad 5.Gang (Z=25)	Engranaje 5º velocidad (Z=25)	
	4	8000 63822	5	Bussola	Bushing	Douille	Buchse	Manguito	
	5	8D00 36022	2	Rosetta	Washer	Rondelle	Scheibe	Arandela	
	6	8000 31772	4	Anello di fermo	Stop ring	Bague d'arrêt	Haltering	Anillo de retención	
	7	8000 88245	1	Ingranaggio 3ª-4ª A.P. (Z=19, Z=23)	Main shaft 3rd- 4th gear (Z=19, Z=23)	Engrenage 3ème- 4ème vitesse A.P. (Z=19, Z=23)	Zahn. f. 3.- 4. Geschw. Antriebsw. (Z=19, Z=23)	Engranaje 3º - 4º velocidad Eje P.(Z=19, Z=23)	
	8	8000 88246	1	Ingranaggio 6ª A.P. (Z=27)	Main shaft 6th gear (Z=27)	Engrenage 6ème vitesse A.P. (Z=27)	Zahn. f. 6. Geschw. Antriebsw. (Z=27)	Engranaje 6º velocidad Eje P. (Z=27)	
	9	8A00 61261	1	Bussola	Bushing	Douille	Buchse	Manguito	
	10	8B00 36023	1	Rosetta di rasamento	Washer	Rondelle	Scheibe	Arandela	
	11	8000 88247	1	Ingranaggio 2ª A.P. (Z=18)	Main shaft 2nd gear (Z=18)	Engr.2ème vitesse A.P. (Z=18)	Zahn. f. 2. Geschw. Antriebsw. (Z=18)	Engranaje 2º velocidad Eje P. (Z=18)	
<b>N</b>	12	8000 A1301	1	Albero secondario completo	Layshaft compl.	Arbre secondaire compl.	Vorgelegewelle kpl.	Eje secundario completo	
	12	8000 A1928	1	Albero secondario completo	Layshaft compl.	Arbre secondaire compl.	Vorgelegewelle kpl.	Eje secundario completo	
	13	8000 A1302	1	Albero secondario	Layshaft	Arbre secondaire	Vorgelegewelle	Eje secundario	
	14	8000 57196	1	Tappo	Plug	Bouchon	Verschluss	Tapón	
<b>&amp;</b>	15	8000 88251	1	Ingranaggio 2ª A.S. (Z=29)	Secondary shaft 2nd gear (Z=29)	Engrenage 2ème vitesse A.S. (Z=29)	Zah. f. 2. Geschw. Vorgelegew. (Z=29)	Engranaje 2º velocidad Eje S. (Z=29)	
	15	8000 A1918	1	Ingranaggio 2ª A.S. (Z=29)	Secondary shaft 2nd gear (Z=29)	Engrenage 2ème vitesse A.S. (Z=29)	Zah. f. 2. Geschw. Vorgelegew. (Z=29)	Engranaje 2º velocidad Eje S. (Z=29)	
	16	66N0 21211	3	Anello di fermo	Stop ring	Bague d'arrêt	Haltering	Anillo de retención	
	17	8000 88254	1	Ingranaggio 4ª A.S. (Z=25)	Secondary shaft 4th gear (Z=25)	Engrenage 4ème vitesse A.S. (Z=25)	Zah. f. 4. Geschw. Vorgelegew. (Z=25)	Engranaje 4º velocidad Eje S. (Z=25)	
	18	8000 88253	1	Ingranaggio 3ª A.S. (Z=25)	Secondary shaft 3rd gear (Z=25)	Engrenage 3ème vitesse A.S. (Z=25)	Zah. f. 3. Geschw. Vorgelegew. (Z=25)	Engranaje 3º velocidad Eje S. (Z=25)	
<b>@</b>	19	8000 88256	1	Ingranaggio 5ª A.S. (Z=23)	Secondary shaft 5th gear (Z=23)	Engrenage 5ème vitesse A.S. (Z=23)	Zah. f. 5. Geschw. Vorgelegew. (Z=23)	Engranaje 5º velocidad Eje S. (Z=23)	
	19	8000 A1920	1	Ingranaggio 5ª A.S. (Z=23)	Secondary shaft 5th gear (Z=23)	Engrenage 5ème vitesse A.S. (Z=23)	Zah. f. 5. Geschw. Vorgelegew. (Z=23)	Engranaje 5º velocidad Eje S. (Z=23)	
<b>@</b>	20	8000 88257	1	Ingranaggio 1ª A.S. (Z=28)	Gear 1st speed (Z=28)	Engrenage 1ère (Z=28)	Zahnrad 1. Gang (Z=28)	Engranaje 1º velocidad (Z=28)	

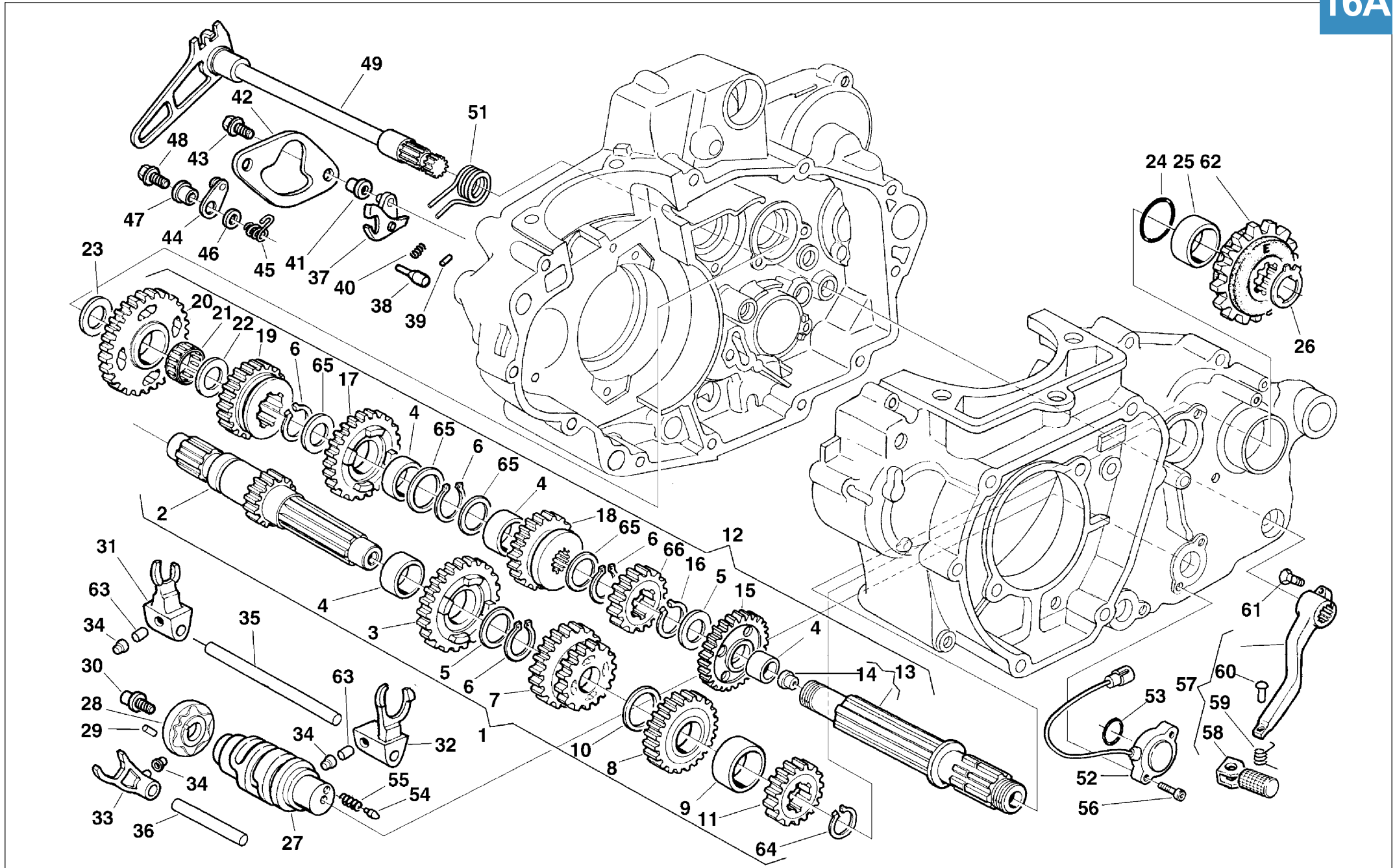

Note Notes Marka Notas	Pos. No. N. Index Pos.	N. Cod. Code No. Nr. Code Code Nr N. Cod.	Q.tà Q.ty Q.te M.ge C.ad	DENOMINAZIONE	NAME	DESIGNATION	BESHREIBUNG	DENOMINACION	Validità Validity Validité Gültig Validez
	20	8000 A1921	1	Ingranaggio 1 <sup>a</sup> A.S. (Z=28)	Gear 1st speed (Z=28)	Engrange 1 <sup>ère</sup> (Z=28)	Zahnrad 1. Gang (Z=28)	Engranaje 1 <sup>º</sup> velocidad (Z=28)	
	21	8000 22373	1	Gabbia a rullini (ø20xø24x10 mm)	Needle cage (ø20xø24x10 mm)	Cage à aiguilles (ø20xø24x10 mm)	Nadelkaefig (ø20xø24x10 mm)	Casquillo(ø20xø24x10 mm)	
	22	8G00 07989	1	Rosetta	Washer	Rondelle	Scheibe	Arandela	
	23	8E00 32069	1	Rosetta	Washer	Rondelle	Scheibe	Arandela	
	24	8000 41693	1	Anello OR	O-Ring	Bague OR	O-Ring	Anillo OR	
	25	8000 86953	1	Distanziale	Spacer	Entretoise	Distanzstück	Separador	
	26	66N0 21211	1	Anello di fermo	Stop ring	Bague d'arrêt	Haltering	Anillo de retención	
	27	8000 A1316	1	Albero forcelle cambio	Driving shaft gearbox forks	Arbre comm. fourches trans.	Antriebswelle Schaltgabel	Eje mando horquilla cambio	
	28	8A00 97739	1	Tamburo selettore marce	Drum	Tambour	Trommel	T%ambor	
	29	8000 38520	1	Rullino	Roller	Aiguille	Rolle	Rodillo	
	30	8000 98149	1	Vite	Screw	Vis	Schraube	Tornillo	
	31	8A00 86980	1	Forcella cambio (1 <sup>a</sup> -4 <sup>a</sup> )	Fork (1 <sup>a</sup> -4 <sup>a</sup> )	Fourche (1 <sup>a</sup> -4 <sup>a</sup> )	Gabel (1 <sup>a</sup> -4 <sup>a</sup> )	Horquilla (1 <sup>a</sup> -4 <sup>a</sup> )	
	32	8A00 48127	1	Forcella cambio (2 <sup>a</sup> -3 <sup>a</sup> )	Fork (2nd-3rd)	Fourche (2 <sup>ème</sup> -3 <sup>ème</sup> )	Gabel (2-3)	Horquilla (2 <sup>º</sup> -3 <sup>º</sup> )	
	33	8000 99738	1	Forcella cambio (5 <sup>a</sup> -6 <sup>a</sup> )	Fork (5th-6th)	Fourche (5 <sup>ème</sup> -6 <sup>ème</sup> )	Gabel (5-6)	Horquilla (5 <sup>º</sup> -6 <sup>º</sup> )	
	34	8000 71010	3	Rotella	Disc	Disque	Scheibe	Disco	
	35	8000 38711	1	Perno (L=96 mm)	Pin (L=96 mm)	Pivot (L=96 mm)	Bolzen (L=96 mm)	Perno (L=96 mm)	
	36	8000 38712	1	Perno (L=57 mm)	Pin (L=57 mm)	Pivot (L=57 mm)	Bolzen (L=57 mm)	Perno (L=57 mm)	
	37	8000 87299	1	Rocchetto selettore dentato	Sprocket	Rochet	Spule	Piñon	
	38	8000 71007	2	Saltarello per rocchetto	Click	Cliquet	Strumhaken	Salt.	
	39	8000 71008	2	Puntale per saltarello	Push rod	Embout	Stösselschaft	Puntal	
	40	8000 71009	2	Molla	Spring	Ressort	Feder	Resorte	
	41	8000 71010	1	Rotella	Disc	Disque	Scheibe	Disco	
	42	8000 99739	1	Piastrina	Plate	Plaque	Platte	Placa	
	43	8000 62726	2	Vite	Screw	Vis	Schraube	Tornillo	
	44	8000 85495	1	Saltarello fissamarce	Click	Cliquet	Strumhaken	Salt.	
	45	8000 A1748	1	Molla	Spring	Ressort	Feder	Resorte	
	46	8000 86107	1	Rosetta di rasamento	Washer	Rondelle	Scheibe	Arandela	
	47	8000 85493	1	Bussola	Bushing	Douille	Buchse	Manguito	
	48	8000 62726	1	Vite	Screw	Vis	Schraube	Tornillo	
	49	8000 91559	1	Albero com. selettore	Gearbox pedal shaft assy	Arbre péd. change vit. compl.	Umsteuerungswelle kpl.	Eje pedal cambio compl.	
	51	8000 72826	1	Molla	Spring	Ressort	Feder	Resorte	

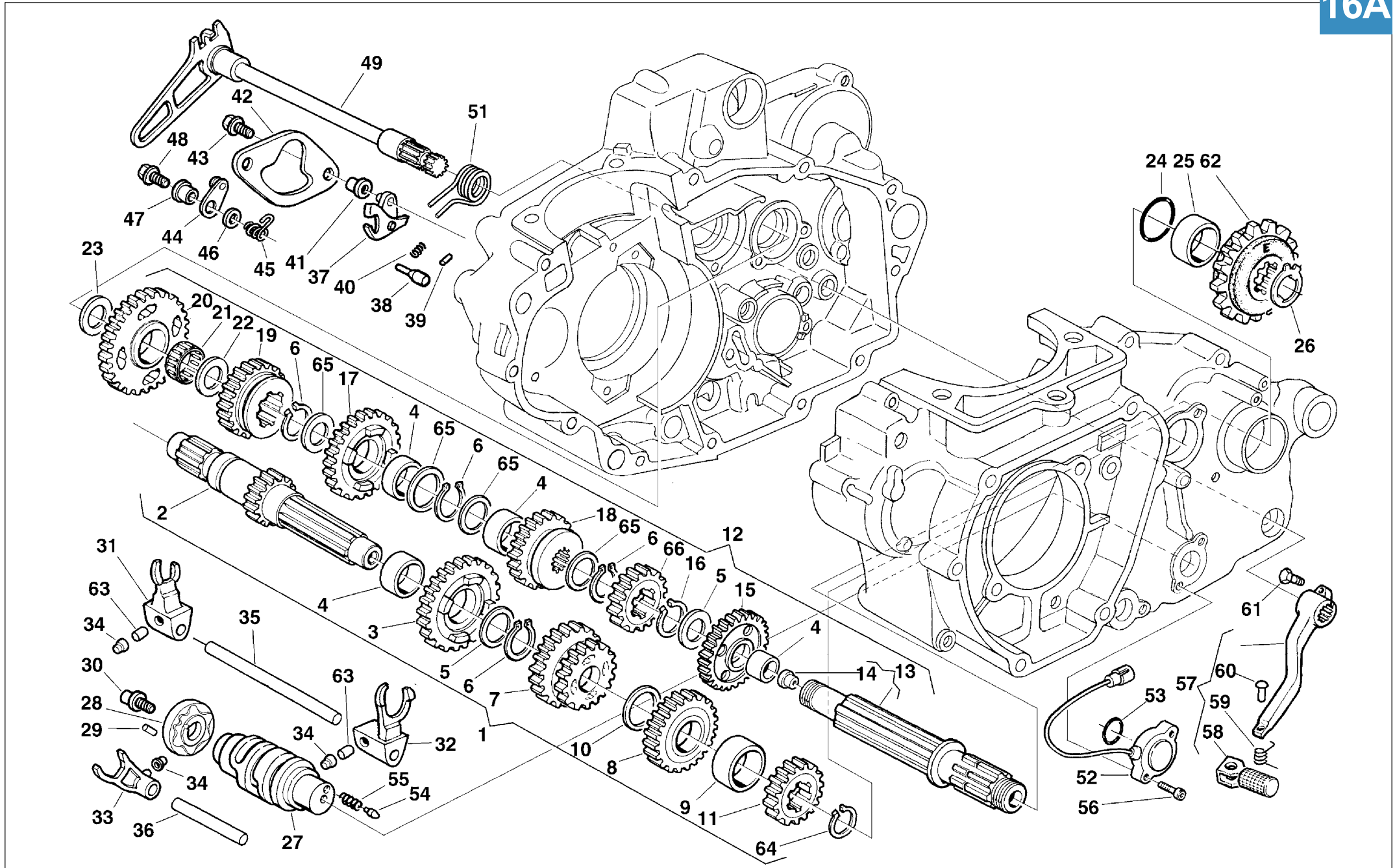



TE 250- 450,  
SM 400R-450R/ 2004

TAVOLA  
DRAWING  
TABLE  
BILD  
TABLA

16A

CAMBIO, COMANDO CAMBIO - TRANSMISSION, SHIFTER  
BOITE DE VITESSE, COMMANDE DE VITESSE  
WECHSELGETRIEBE, GANGSCHALTUNG - CAMBIO, MANDO CAMBIO

6 SPEED

Note Notes Notes Marke Notas	Pos. No. N. Index Pos.	N. Cod. Code No. Nr. Code Code Nr N. Cod.	Q.tà Q.ty Q.té M.g.e C.ad	DENOMINAZIONE	NAME	DESIGNATION	BESHREIBUNG	DENOMINACION	Validità Validity Validité Gültig Validez
	52	8000 A0579	1	Segnalatore folle	Idle trasponder assy	Signaleur point mort compl.	Leerlauflicht kpl.	Señalador compl.	
	53	8A00 42700	1	Anello OR	O-Ring	Bague OR	O-Ring	Anillo OR	
	54	8000 42676	1	Puntale per segnalatore marce	Push rod	Embout	Stösselschaft	Puntal	
	55	8000 42677	1	Molla	Spring	Ressort	Feder	Resorte	
	56	8000 66525	2	Vite	Screw	Vis	Schraube	Tornillo	
<b>E</b>	57	8000 99741	1	Leva comando cambio	Gearchange lever assy	Levier comm. vitesse compl.	Schalthebel kpl.	Palanca del cambio compl.	
	57	8000 A3488	1	Leva comando cambio	Gearchange lever assy	Levier comm. vitesse compl.	Schalthebel kpl.	Palanca del cambio compl.	
<b>E</b>	58	8000 A3485	1	Pedale leva comando cambio	Gearchange lever pedal	Pedale	Pedal	Pedal	
	58	8A00 A3485	1	Pedale leva comando cambio	Gearchange lever pedal	Pedale	Pedal	Pedal	
	59	8000 70216	1	Molla	Spring	Ressort	Feder	Resorte	
	60	8000 99744	1	Ribattino	Rivet	Rivet	Niet	Remache	
	61	8000 62728	1	Vite	Screw	Vis	Schraube	Tornillo	
<b>R</b>	62	8000 63827	1	Pignone Z=12	Pinion Z=12	Pignon Z=12	Ritzel Z=12	Piñón Z=12	
	62	8000 63828	1	Pignone Z=13 (TE 250)	Pinion Z=13 (TE 250)	Pignon Z=13 (TE 250)	Ritzel Z=13 (TE 250)	Piñón Z=13 (TE 250)	
	62	8000 63829	1	Pignone Z=14 (TE 450)	Pinion Z=14 (TE 450)	Pignon Z=14 (TE 450)	Ritzel Z=14 (TE 450)	Piñón Z=14 (TE 450)	
	62	8000 63830	1	Pignone Z=15 (SMR 450)	Pinion Z=15 (SMR 450)	Pignon Z=15 (SMR 450)	Ritzel Z=15 (SMR 450)	Piñón Z=15 (SMR 450)	
<b>D</b>	62	8000 63831	1	Pignone Z=16 (SMR)	Pinion Z=16 (SMR)	Pignon Z=16 (SMR)	Ritzel Z=16 (SMR)	Piñón Z=16 (SMR)	
	63	8000 38728	2	Rullino	Roller	Aiguille	Rolle	Rodillo	
	64	66N0 21206	1	Anello di fermo	Stop ring	Bague d'arrêt	Haltering	Anillo de retención	
	65	8000 88255	4	Rosetta di rasamento	Washer	Rondelle	Scheibe	Arandela	
<b>&amp;</b>	66	8000 88252	1	Ingranaggio 6 <sup>a</sup> A.S. (Z=22)	Secondary shaft 6th gear (Z=22)	Engrenage 6ème vitesse A.S. (Z=22)	Zahn. f. 6. Geschw. Vorgelegew. (Z=22)	Engranaje6° velocidad Eje S. (Z=22)	
	66	8000 A1919	1	Ingranaggio 6 <sup>a</sup> A.S. (Z=22)	Secondary shaft 6th gear (Z=22)	Engrenage 6ème vitesse A.S. (Z=22)	Zahn. f. 6. Geschw. Vorgelegew. (Z=22)	Engranaje6° velocidad Eje S. (Z=22)	
<b>&amp;</b>				Dare coppia ingranaggi 8000A1918 (2 <sup>a</sup> ) e 8000A1919 (6 <sup>a</sup> )	Supply by pairs the gears 8000A1918 (2 <sup>a</sup> ) and 8000A1919 (6 <sup>a</sup> )	Fournir engrenage par paire 8000A1918 (2 <sup>a</sup> ) et 8000A1919 (6 <sup>a</sup> )	Zahnrad Paarweise geliefert 8000A1918 (2 <sup>a</sup> ) und 8000A1919 (6 <sup>a</sup> )	Equipar engranaje parejados 8000A1918 (2 <sup>a</sup> ) y 8000A1919 (6 <sup>a</sup> )	
<b>@</b>				Dare coppia ingranaggi 8000A1920 (5 <sup>a</sup> ) e 8000A1921 (1 <sup>a</sup> )	Supply by pairs the gears 8000A1920 (5 <sup>a</sup> ) and 8000A1921 (1 <sup>a</sup> )	Fournir engrenage par paire 8000A1920 (5 <sup>a</sup> ) et 8000A1921 (1 <sup>a</sup> )	Zahnrad Paarweise geliefert 8000A1920 (5 <sup>a</sup> ) und 8000A1921 (1 <sup>a</sup> )	Equipar engranaje parejados 8000A1920 (5 <sup>a</sup> ) y 8000A1921 (1 <sup>a</sup> )	



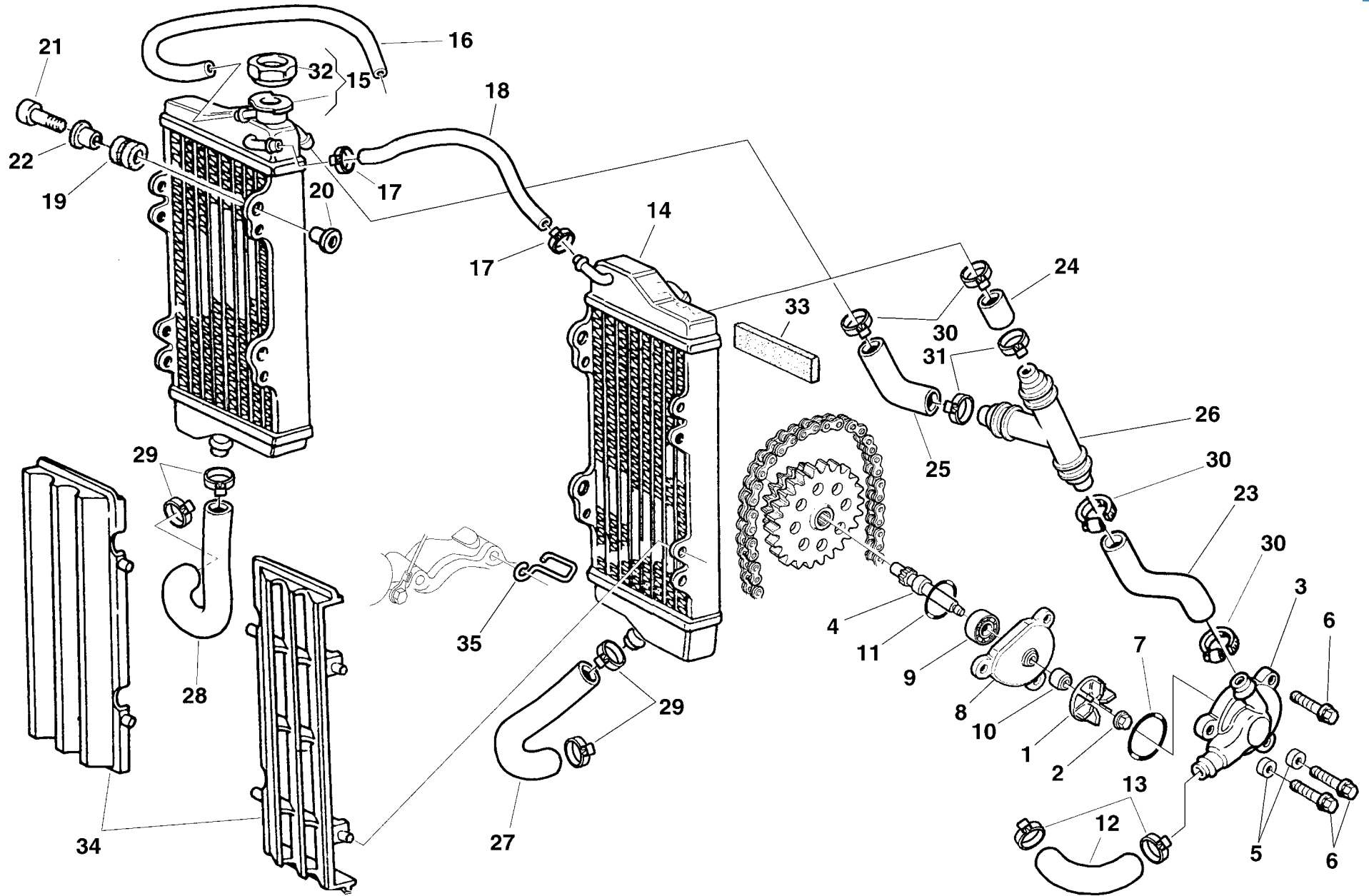





**TC-TE 250- 450,  
SM 400R-450R/ 2004**

TAVOLA  
DRAWING  
TABLE  
BILD  
TABLA

**17**

**RAFFREDDAMENTO - COOLING SYSTEM  
REFROIDISSEMENT - WASSERKÜHLUNG  
ENFRIAMIENTO**

Note Notes Notas	Pos. No. Index Pos.	N. Cod. Code No. Nr. Code Code Nr N. Cod.	Q.tà Q.ty Q.te M.ge C.ad	DENOMINAZIONE	NAME	DESIGNATION	BESHREIBUNG	DENOMINACION	Validità Validity Validité Gültig Validez
	1	8A00 60415	1	Girante	Rotor	Couronne	Laufgrad	Rotor	
	2	8000 42278	1	Dado	Nut	Ecrou	Mutter	Tuerca	
	3	8000 91564	1	Corpo pompa	Pump body	Corps pompe	Pumpenkörper	Corpo bomba	
	4	8000 99707	1	Albero pompa acqua	Water pump shaft	Arbre	Welle	Eje	
	5	1617 95501	2	Bussola	Bushing	Douille	Buchse	Manguito	
	6	8000 62730	3	Vite (M6x30 mm)	Screw (M6x30 mm)	Vis (M6x30 mm)	Schraube (M6x30 mm)	Tornillo (M6x30 mm)	
	7	8000 27122	1	Anello OR	O-Ring	Bague OR	O-Ring	Anillo OR	
	8	8000 91565	1	Flangia	Flange	Bride	Flansch	Brida	
	9	8000 34317	1	Cuscinetto (ø12xø28x8 mm)	Bearing (ø12xø28x8 mm)	Roulement (ø12xø28x8 mm)	Lager (ø12xø28x8 mm)	Cojinete (ø12xø28x8 mm)	
	10	8000 53339	1	Anello di tenuta (ø8xø16x10 mm)	Seal ring (ø8xø16x10 mm)	Bague d'étanchéité (ø8xø16x10 mm)	Dichtungsring (ø8xø16x10 mm)	Anillo de retención (ø8xø16x10 mm)	
	11	8000 40007	1	Anello OR	O-Ring	Bague OR	O-Ring	Anillo OR	
	12	8000 99708	1	Tubo TESTA - POMPA	Pipe	Tuyau	Schlauch	Tubo	
	13	8B00 99475	2	Fascetta	Clamp	Collier	Schelle	Banda	
	14	8000 99659	1	Radiatore SINISTRO	L.H. radiator	Radiateur G.	L., Kühler	Radiador izrdo.	
	15	8000 99658	1	Radiatore DESTRO completo	R.H. radiator compl.	Radiateur D. compl.	R., Kühler kpl.	Radiador derech. compl.	
	16	8B00 43715	1	Tubetto sfiato	Tube	Tuyau	Rohr	Tubo	
	17	8000 56462	2	Fascetta	Clamp	Collier	Schelle	Banda	
	18	8D00 43716	1	Tubo	Pipe	Tuyau	Schlauch	Tubo	
	19	8000 59803	6	Gommino	Rubber pad	Pièce caoutchouc	Gummstück	Junta de goma	
	20	8000 59802	6	Bussola	Bushing	Douille	Buchse	Manguito	
	21	8000 62728	6	Vite (M6x20 mm)	Screw (M6x20 mm)	Vis (M6x20 mm)	Schraube (M6x20 mm)	Tornillo (M6x20 mm)	
	22	8000 59801	6	Rosetta piana	Washer	Rondelle	Scheibe	Arandela	
	23	8000 99660	1	Tubo POMPA-RACCORDO (TE-TC 250)	Pipe (TE-TC 250)	Tuyau (TE-TC 250)	Schlauch (TE-TC 250)	Tubo (TE-TC 250)	
	23	8A00 99660	1	Tubo POMPA-RACCORDO (400-450)	Pipe (400-450)	Tuyau (400-450)	Schlauch (400-450)	Tubo (400-450)	
	24	8000 A0669	1	Tubo RAD. SX-RACCORDO	Pipe	Tuyau	Schlauch	Tubo	
	25	8000 A0670	1	Tubo RAD. DX-RACCORDO	Pipe	Tuyau	Schlauch	Tubo	
	26	8000 A0671	1	Raccordo	Union	Raccord	Anschluss	Empalme	
	27	8000 99661	1	Tubo INFERIORE RAD. SX	Pipe	Tuyau	Schlauch	Tubo	
	28	8000 A0779	1	Tubo INFERIORE RAD. DX	Pipe	Tuyau	Schlauch	Tubo	
	29	8A00 99475	4	Fascetta	Clamp	Collier	Schelle	Banda	

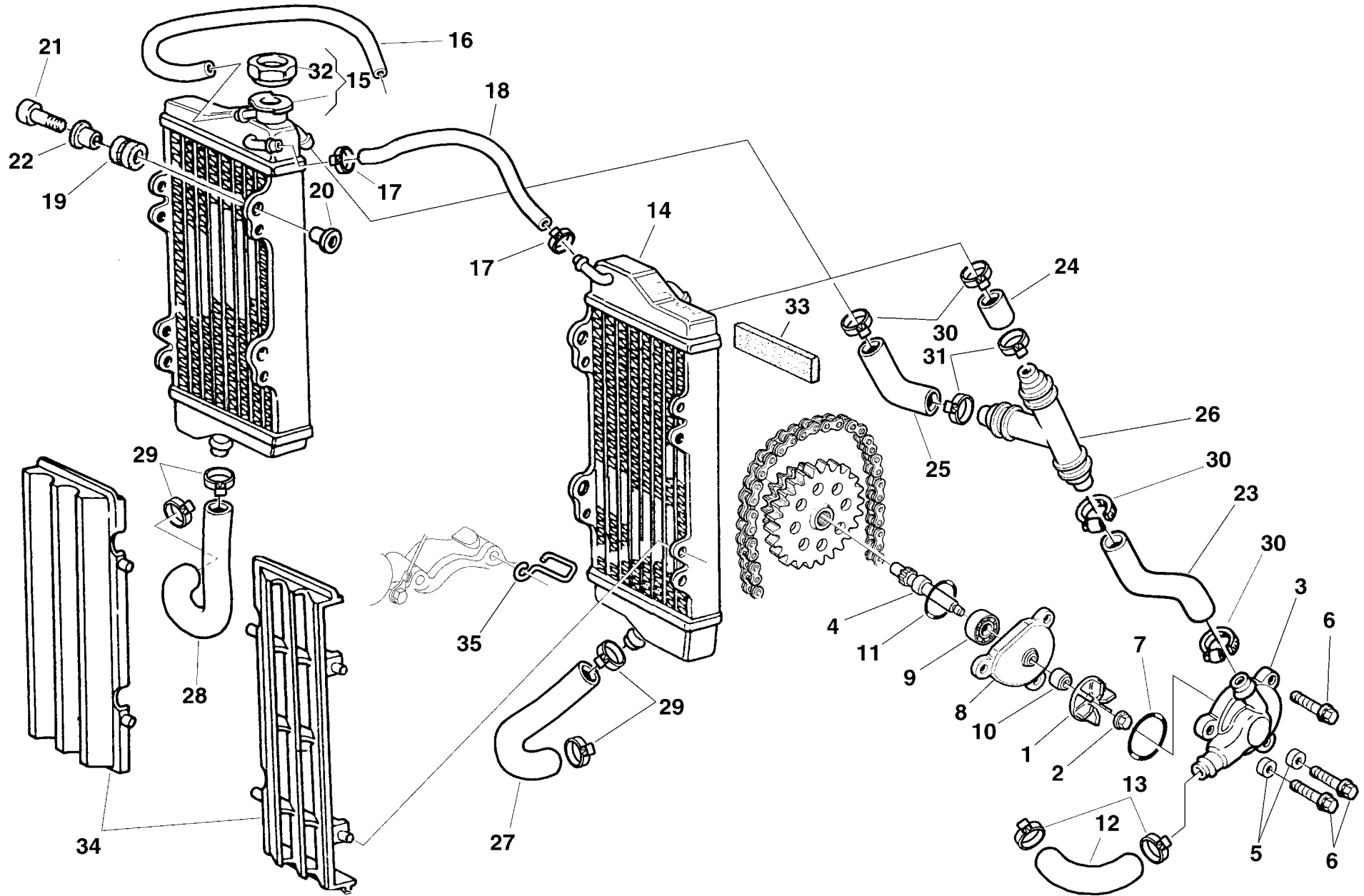



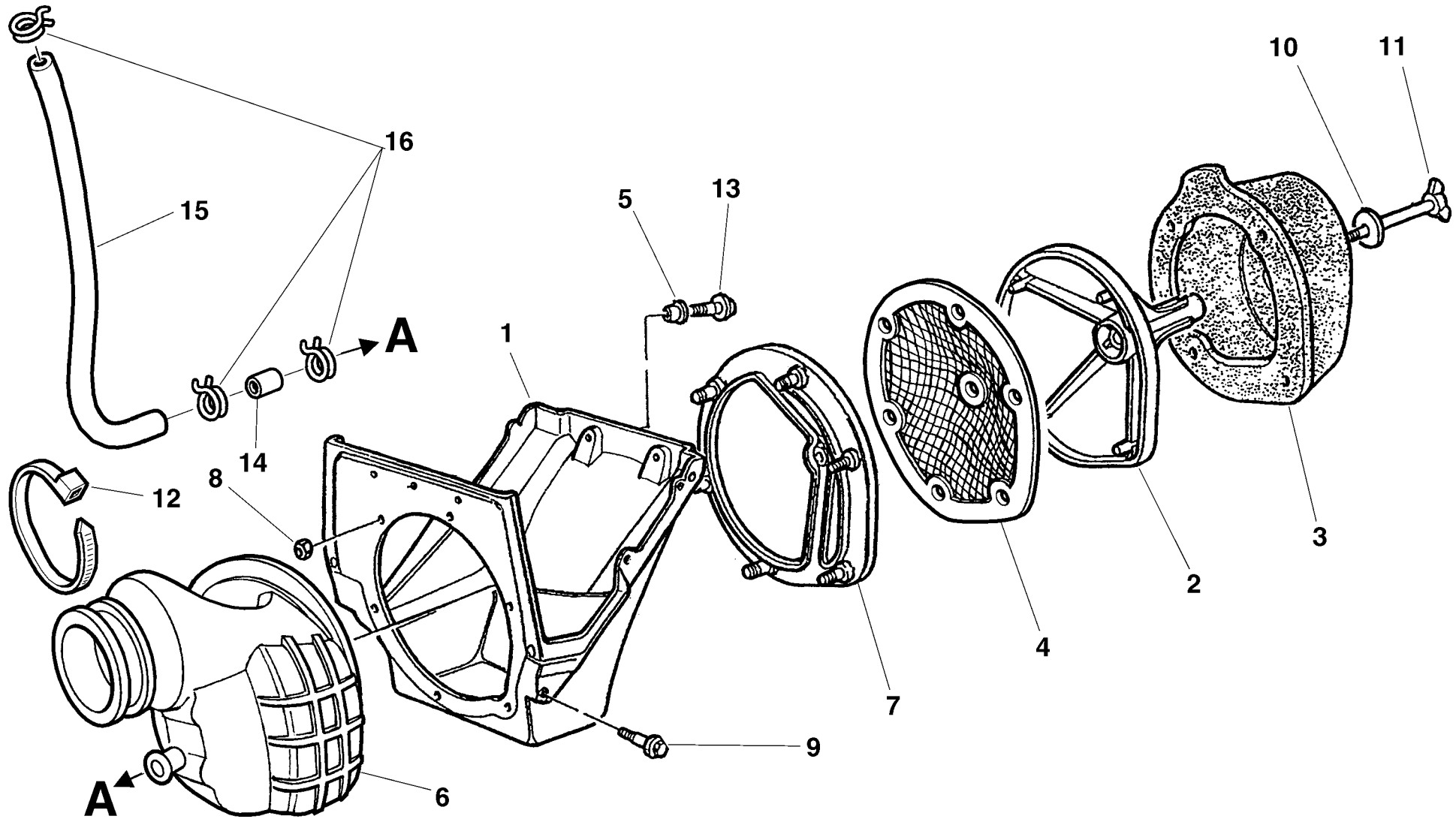



**TC-TE 250- 450,  
SM 400R-450R/ 2004**

TAVOLA  
DRAWING  
TABLE  
BILD  
TABLA

**18**

**FILTRO ARIA - AIR FILTER  
FILTRE AIRE - LUFTFILTER  
FILTRO DE AIRE**

Note Notes Markes Notas	Pos. No. N. Index Pos.	N. Cod. Code No. Nr. Code Code Nr N. Cod.	Q.tà Q.ty Q.te M.ge C.ad	DENOMINAZIONE	NAME	DESIGNATION	BESHREIBUNG	DENOMINACION	Validità Validity Validité Gültig Validez
	1	80A0 91792	1	Scatola filtro aria	Air filter box	Boîte filtre	Filterkasten	Caja filtro aire	
	2	8000 69549	1	Gabbia filtro	Cleaner cage	Cage pour filtre	Filterkafig	Caja filtro	
	3	8000 72641	1	Filtro aria	Air filter	Filtre à air	Luftfilter	Filtro aire	
	4	8000 A0656	1	Protezione antifiamma	Guard	Protection	Schutz	Protección	
	5	8000 69429	2	Bussola	Bushing	Duille	Buchse	Manguito	
	6	8000 99630	1	Raccordo (250)	Union (250)	Raccord (250)	Anschluss (250)	Empalme (250)	
	6	8000 A0681	1	Raccordo (400 - 450)	Union (400 - 450)	Raccord (400 - 450)	Anschluss (400 - 450)	Empalme (400 - 450)	
	7	8000 70024	1	Flangia	Flange	Bride	Flansch	Brida	
	8	8000 40718	6	Dado	Nut	Ecrou	Mutter	Tuerca	
	9	8000 62726	2	Vite (M6x14 mm)	Screw (M6x14 mm)	Vis (M6x14 mm)	Schraube (M6x14 mm)	Tornillo (M6x14 mm)	
	10	62N1 15549	1	Rosetta piana	Washer	Rondelle	Scheibe	Arandela	
	11	8A00 37947	1	Vite	Screw	Vis	Schraube	Tornillo	
	12	8E00 99475	1	Fascetta	Clamp	Collier	Schelle	Banda	
	13	8000 62728	2	Vite (M6x20 mm)	Screw (M6x20 mm)	Vis (M6x20 mm)	Schraube (M6x20 mm)	Tornillo (M6x20 mm)	
	14	8000 A0900	1	Raccordo	Union	Raccord	Anschluss	Empalme	
	15	8000 A0902	1	Tubetto sfiato (L=325 mm)	Breather pipe (L=325 mm)	Tuyau évent (L=325 mm)	Entlüftungsrohr (L=325 mm)	Tubo de purga (L=325 mm)	
	16	8H00 95276	3	Fascetta	Clamp	Collier	Schelle	Banda	

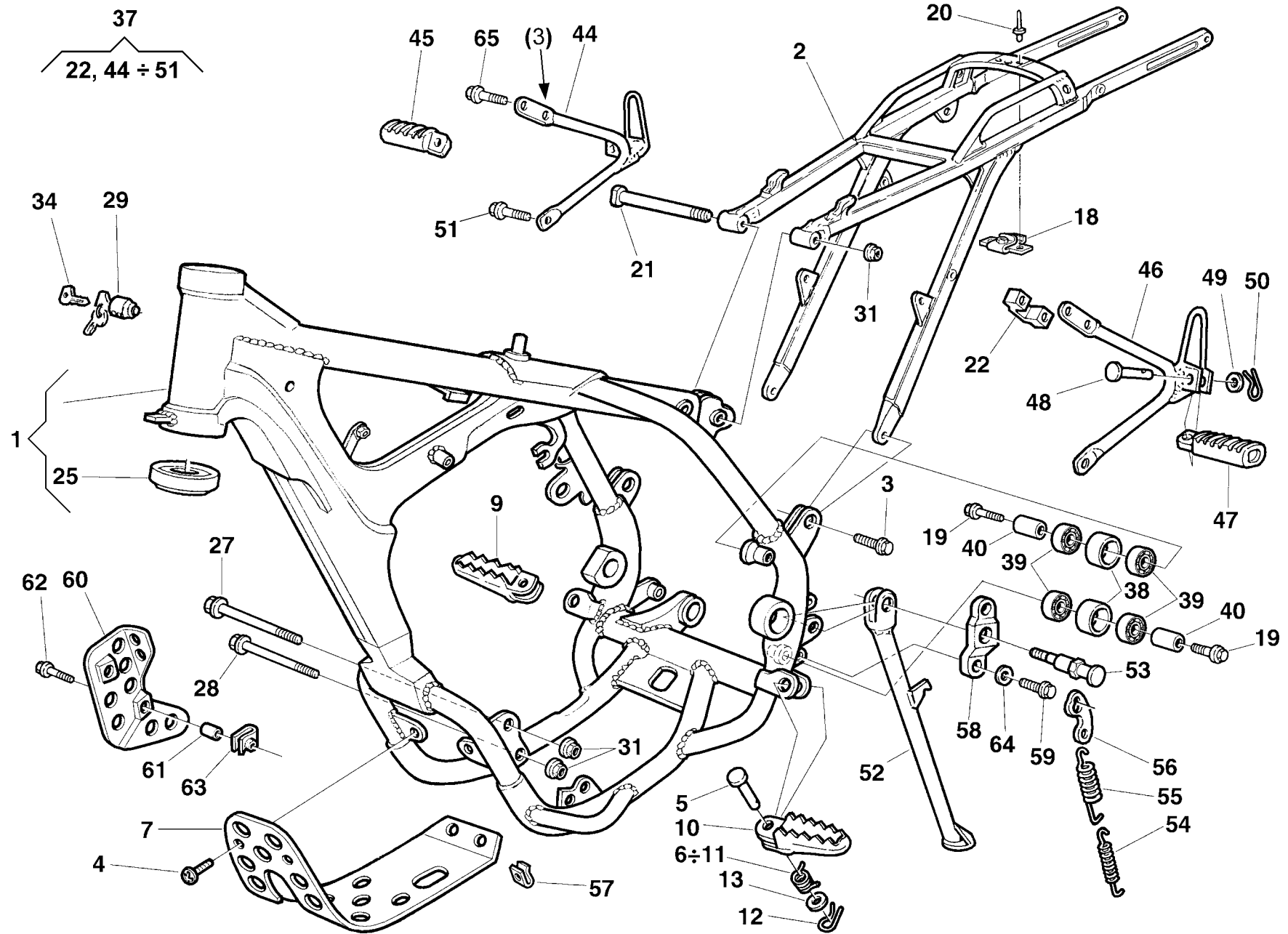



Note Notes Notas	Pos. No. Index Pos.	N. Cod. Code No. Nr. Code Code Nr N. Cod.	Q.tà Q.ty Q.te M.ge C.ad	DENOMINAZIONE	NAME	DESIGNATION	BESHREIBUNG	DENOMINACION	Validità Validity Validité Gültig Validez
	1	8A00 99587	1	Telaio (TE)	Frame (TE)	Chassis (TE)	Rahmen (TE)	Bastidor (TE)	
	1	8C00 99587	1	Telaio (TE USA)	Frame (TE USA - SMR USA)	Chassis (TE USA - SMR USA)	Rahmen (TE USA - SMR USA)	Bastidor (TE USA - SMR USA)	
	1	8E00 99587	1	Telaio (TC)	Frame (TC)	Chassis (TC)	Rahmen (TC)	Bastidor (TC)	
	1	8G00 99587	1	Telaio (SMR)	Frame (SMR)	Chassis (SMR)	Rahmen (SMR)	Bastidor (SMR)	
	1	8N00 99587	1	Telaio (SMR USA)	Frame (SMR USA)	Chassis (SMR USA)	Rahmen (SMR USA)	Bastidor (SMR USA)	
	2	8000 A0597	1	Parte posteriore telaio	Rear frame side	Chassis arrière	Sattelbrücke	Cuadro posterior	
	3	8000 69056	2	Vite (M8x20 mm)	Screw (M8x20 mm)	Vis (M8x20 mm)	Schraube (M8x20 mm)	Tornillo (M8x20 mm)	
<b>D</b>	4	8000 60898	4	Vite (M6x15 mm)	Screw (M6x15 mm)	Vis (M6x15 mm)	Schraube (M6x15 mm)	Tornillo (M6x15 mm)	
	5	8000 73140	2	Perno	Pin	Goupille	Stift	Clavija	
	6	8000 96907	1	Molla Sx	L.H. spring	Ressort G.	Feder L.	Resorte Iz.	
<b>D</b>	7	8000 A0865	1	Paramotore	Engine guard	Garde moteur	Motorschutz	Para motor	
	9	80A0 89953	1	Pedana destra	R.H. foot-rest	Repose-pieds D.	R. Fussraste	Pedal delnt. derech. compl.	
	10	80A0 89962	1	Pedana sinistra	L.H. foot-rest	Repose-pieds G.	L. Fussraste	Pedal delant. izrdo. compl.	
	11	8000 96908	1	Molla Dx	R.H. spring	Ressort D.	Feder R.	Resorte Der.	
	12	64N1 20068	2	Copiglia	Split pin	Goupille	Splint	Clavija	
	13	8A00 01815	2	Rosetta	Washer	Rondelle	Scheibe	Arandela	
	18	8000 69150	1	Piastrina	Plate	Plaque	Plättchen	Placa	
	19	8000 62796	2	Vite (M8x40 mm)	Screw (M8x40 mm)	Vis (M8x40 mm)	Schraube (M8x40 mm)	Tornillo (M8x40 mm)	
	20	8000 33373	2	Rivetto	Rivet	Rivet	Niet	Remache	
	21	8000 69111	1	Vite (M8x130 mm)	Screw (M8x130 mm)	Vis (M8x130 mm)	Schraube (M8x130 mm)	Tornillo (M8x130 mm)	
<b>DX</b>	22	8A00 71091	2	Cavallotto (TE, SMR)	U-bolt (TE, SMR)	Cavalier (TE, SMR)	Bügelbolzen (TE, SMR)	Caballote (TE, SMR)	
<b>WM</b>	25	1513 07001	2	Cuscinetto a rulli conici (ø25xø50x17,5 mm)	Bearing (ø25xø50x17,5 mm)	Roulement à rouleaux coniques (ø25xø50x17,5 mm)	Lager (ø25xø50x17,5 mm)	Cojinete de rodillos cónicos (ø25xø50x17,5 mm)	
<b>C</b>	25	8000 87243	2	Cuscinetto a rulli conici (ø29xø48x17,5 mm)	Bearing (ø29xø48x17,5 mm)	Roulement à rouleaux coniques (ø29xø48x17,5 mm)	Lager (ø29xø48x17,5 mm)	Cojinete de rodillos cónicos (ø29xø48x17,5 mm)	
	27	8G00 73458	1	Perno ant. fiss. motore (M8x150 mm)	Pin (M8x150 mm)	Pivot (M8x150 mm)	Bolzen (M8x150 mm)	Perno (M8x150 mm)	
	28	8G00 73458	1	Perno inf. fiss. motore (M8x150 mm)	Pin (M8x150 mm)	Pivot (M8x150 mm)	Bolzen (M8x150 mm)	Perno (M8x150 mm)	
<b>XY</b>	29	8000 43391	1	Serratura antifurto completa	Anti-left lock assy	Serrure anti-vol compl.	Sicherheitsschloss kpl.	Cerradura compl.	
	31	8000 43928	3	Dado	Nut	Ecrou	Mutter	Tuerca	
<b>XY</b>	34	8000 35531	1	Chiave grezza	Raw key	Clef primitive	Schlüssel	Llave	
<b>DX</b>	37	8000 A0677	1	Kit poggiapiedi (TE, SMR)	Compl. footrest Kit (TE, SMR)	Appui-pied complet (TE, SMR)	kpl. Fussraster-Kit (TE, SMR)	Kit apoyapiés (TE, SMR)	

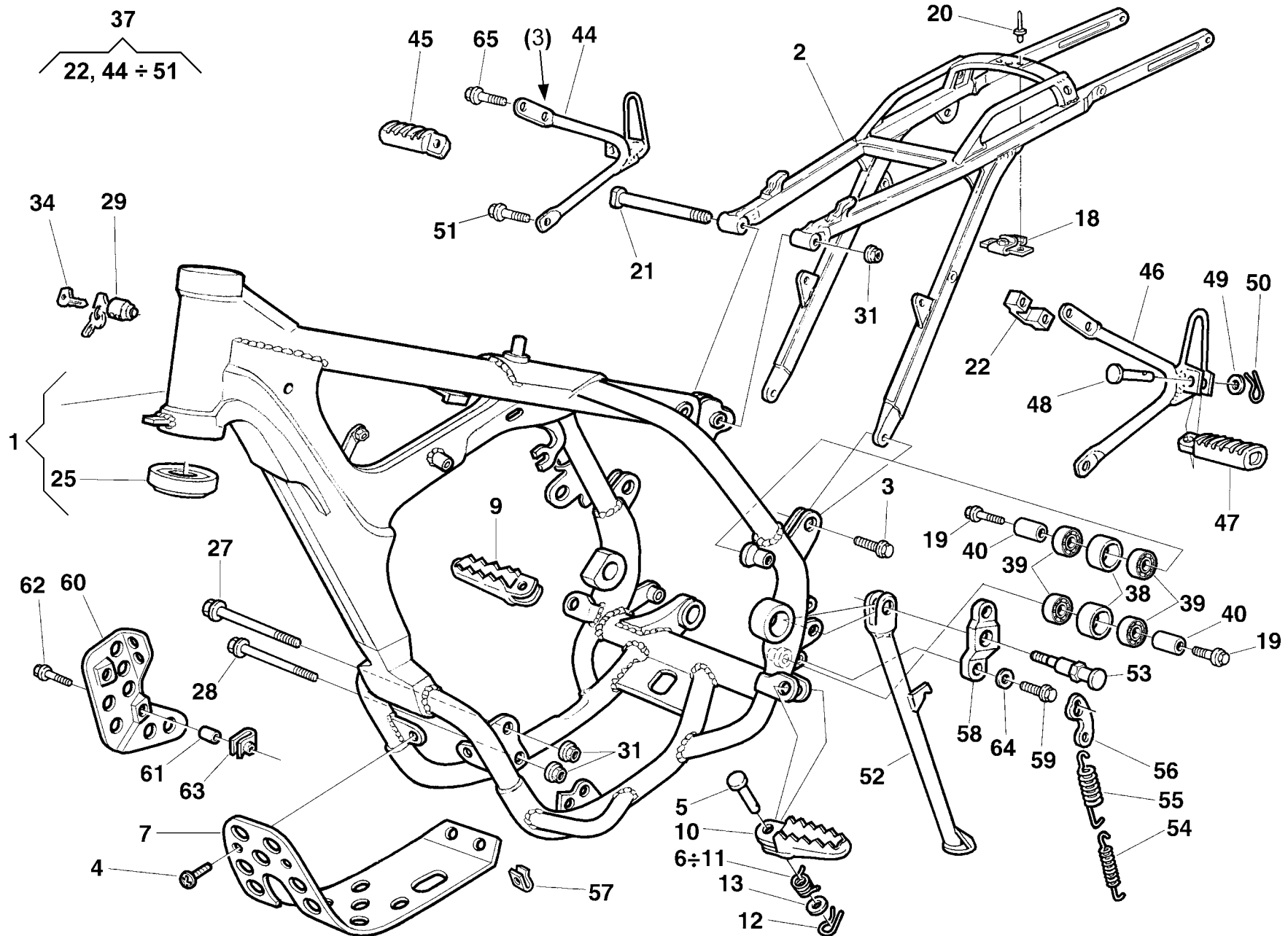



TC-TE 250- 450,  
SM 400R-450R/ 2004

TAVOLA  
DRAWING  
TABLE  
BILD  
TABLA

19

TELAIO, PEDANE - FRAME, FOOT RESTS  
CADRE, REPOSE PIEDS - RAHMEN, FUSSBRETT  
BASTIDOR, REPOSAPIES

Note Notes Notas	Pos. No. Index Pos.	N. Cod. Code No. Nr. Code Code Nr N. Cod.	Q.tà Q.ty M.ge C.ad	DENOMINAZIONE	NAME	DESIGNATION	BESHREIBUNG	DENOMINACION	Validità Validity Validité Gültig Validez
	38	8A00 59433	2	Rullo catena	Roller	Aiguille	Rolle	Rodillo	
	39	8000 63312	4	Cuscinetto (ø8xØ22x7 mm)	Bearing (ø8xØ22x7 mm)	Roulement (ø8xØ22x7 mm)	Kugellager (ø8xØ22x7 mm)	Cojinete (ø8xØ22x7 mm)	
	40	8A00 59434	2	Distanziale	Spacer	Entretoise	Distanzstück	Separador	
<b>DX</b>	44	8000 A0676	1	Supporto Dx (TE, SMR)	R.H. support (TE, SMR)	Support D. (TE, SMR)	Halterung R. (TE, SMR)	Soporte der. (TE, SMR)	
<b>DX</b>	45	8000 66652	1	Poggiapiedi passeggero Dx. (TE, SMR)	R.H. foot rest support (TE, SMR)	Support repose pied D. (TE, SMR)	R. Fussraster (TE, SMR)	Posapie der. (TE, SMR)	
<b>DX</b>	46	8000 A0675	1	Supporto Sx. (TE, SMR)	L.H. support (TE, SMR)	Support G. (TE, SMR)	Halterung L. (TE, SMR)	Soporte izq. (TE, SMR)	
<b>DX</b>	47	8000 66651	1	Poggiapiedi passeggero Sx. (TE, SMR)	L.H. foot rest support (TE, SMR)	Support repose pied G. (TE, SMR)	L. Fussraster (TE, SMR)	Posapie izq. (TE, SMR)	
<b>DX</b>	48	8000 41459	2	Perno (TE, SMR)	Pin (TE, SMR)	Pivot (TE, SMR)	Bolzen (TE, SMR)	Perno (TE, SMR)	
<b>DX</b>	49	62N1 15504	2	Rosetta (TE, SMR)	Washer (TE, SMR)	Rondelle (TE, SMR)	Scheibe (TE, SMR)	Arandela (TE, SMR)	
<b>DX</b>	50	64N1 20048	2	Copiglia (TE, SMR)	Split pin (TE, SMR)	Goupille (TE, SMR)	Splint (TE, SMR)	Clavija (TE, SMR)	
<b>DX</b>	51	8000 62732	2	Vite (M8x25 mm) (TE, SMR)	Screw (M8x25 mm) (TE, SMR)	Vis (M8x25 mm) (TE, SMR)	Schraube (M8x25 mm) (TE, SMR)	Tornillo (M8x25 mm) (TE, SMR)	
<b>W</b>	52	8000 A0264	1	Gamba laterale	Side stand	Bequille laterale	Seitenständer	Horquilla lateral	
<b>M</b>	52	8A00 A0264	1	Gamba laterale	Side stand	Bequille laterale	Seitenständer	Horquilla lateral	
	53	8000 A0266	1	Vite (M8x25 mm)	Screw (M8x25 mm)	Vis (M8x25 mm)	Schraube (M8x25 mm)	Tornillo (M8x25 mm)	
<b>Y</b>	54	8000 A0268	1	Molla interna	Spring	Ressort	Feder	Resorte	
<b>Y</b>	55	8000 A0269	1	Molla esterna	Spring	Ressort	Feder	Resorte	
<b>Y</b>	56	8000 A0267	1	Piastrina	Plate	Plaque	Platte	Plaque	
<b>D</b>	57	8000 46893	4	Dado	Nut	Ecrou	Mutter	Tuerca	
<b>Y</b>	58	8000 99613	1	Piastrina	Plate	Plaque	Platte	Plaque	
<b>Y</b>	59	60N1 01140	2	Vite (M7x16 mm)	Screw (M7x16 mm)	Vis (M7x16 mm)	Schraube (M7x16 mm)	Tornillo (M7x16 mm)	
<b>D</b>	60	8000 A1427	1	Protezione carter destro (TC, TE)	R.H. crankcase guard (TC, TE)	Protection carter D. (TC, TE)	Gehäusedeckelschutz Rechts (TC, TE)	Protección carter derecha (TC, TE)	
<b>D</b>	61	8A00 67207	2	Distanziale (TC, TE)	Spacer (TC, TE)	Entretoise (TC, TE)	Distanzstück (TC, TE)	Separador (TC, TE)	
<b>D</b>	62	8000 62730	2	Vite (TC, TE)	Screw (TC, TE)	Vis (TC, TE)	Schraube (TC, TE)	Tornillo (TC, TE)	
<b>D</b>	63	8000 46893	2	Dado (TC, TE)	Nut (TC, TE)	Ecrou (TC, TE)	Mutter (TC, TE)	Tuerca (TC, TE)	
<b>Y</b>	64	62N1 15538	2	Rosetta D14,4-d8,4-Sp2	Washer D14,4-d8,4-th.2	Rondelle D14,4-d8,4-ép2	Scheibe D14,4-d8,4-Sp.2	Arandela D14,4-d8,4-esp.2	
<b>DX</b>	65	8B00 69056	2	Vite (M8x15 mm) (TE, SMR)	Screw (M8x15 mm) (TE, SMR)	Vis (M8x15 mm) (TE, SMR)	Schraube (M8x15 mm) (TE, SMR)	Tornillo (M8x15 mm) (TE, SMR)	

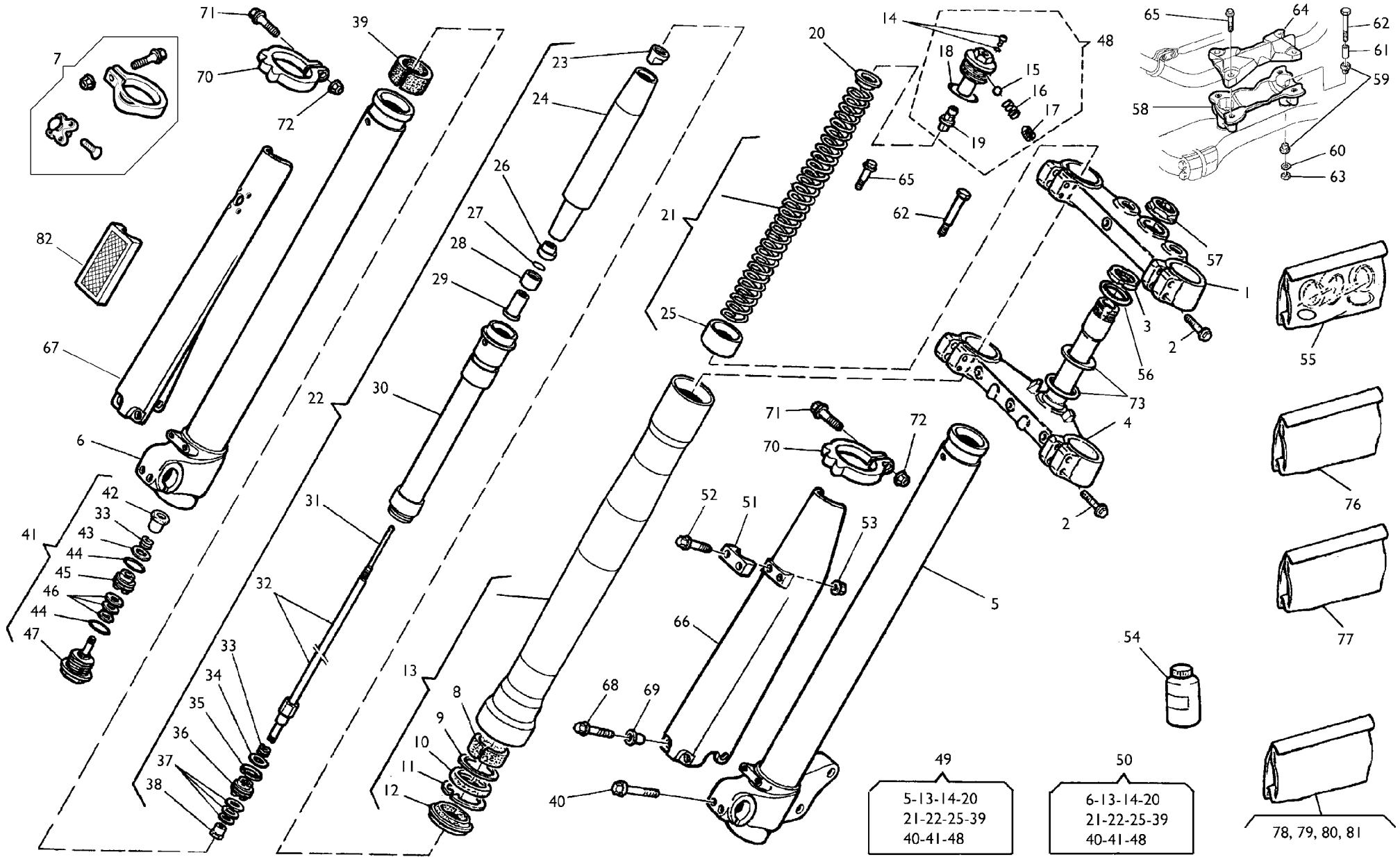



**TC-TE 250- 450,  
SM 400R-450R/ 2004**

TAVOLA  
DRAWING  
TABLE  
BILD  
TABLA

**20**

**SOSPENSIONE ANTERIORE - FRONT FORK ASSEMBLY  
SUSPENSION AVANT - VORDERTELESKOPGABEL  
SUSPENSION DELANTERA**

Note Notes Notas	Pos. No. Index Pos.	N. Cod. Code No. Nr. Code Code Nr N. Cod.	Q.tà Q.ty Q.te M.ge C.ad	DENOMINAZIONE	NAME	DESIGNATION	BESCHREIBUNG	DENOMINACION	Validità Validity Validité Gültig Validez
<b>W</b>	1	8A00 96811	1	Testa di sterzo	Steering head	Tête direction	Lenkkopf	Cabezal de dirección	
<b>C</b>	1	8000 96811	1	Testa di sterzo	Steering head	Tête direction	Lenkkopf	Cabezal de dirección	
<b>M</b>	1	8000 95703	1	Testa di sterzo	Steering head	Tête direction	Lenkkopf	Cabezal de dirección	
	2	8000 62796	8	Vite (M8x40 mm)	Screw (M8x40 mm)	Vis (M8x40 mm)	Schraube (M8x40 mm)	Tornillo (M8x40 mm)	
<b>WM</b>	3	8000 83395	1	Ghiera registro cuscinetti	Ring nut	Embout	Nutmutter	Viol	
<b>C</b>	3	8A00 87717	1	Ghiera registro cuscinetti	Ring nut	Embout	Nutmutter	Viol	
<b>W</b>	4	8000 96897	1	Base di sterzo con perno	Steering crown with pin	Socle de direction avec pivot	Gabelbrücke mit Bolzen	Base de dirección con perno	
<b>C</b>	4	8000 96813	1	Base di sterzo con perno	Steering crown with pin	Socle de direction avec pivot	Gabelbrücke mit Bolzen	Base de dirección con perno	
<b>M</b>	4	8000 95702	1	Base di sterzo con perno	Steering crown with pin	Socle de direction avec pivot	Gabelbrücke mit Bolzen	Base de dirección con perno	
<b>WC</b>	5	8000 98787	1	Stelo Sx. compl.	L.H. slider assy	Montant G. compl.	Bein, Kpl. L.	Deslizable izrda. compl.	
<b>E&amp;M</b>	5	8000 96643	1	Stelo Sx. compl.	L.H. slider assy	Montant G. compl.	Bein, Kpl. L.	Deslizable izrda. compl.	
<b>M</b>	5	8A00 96643	1	Stelo Sx. compl.	L.H. slider assy	Montant G. compl.	Bein, Kpl. L.	Deslizable izrda. compl.	
	6	8000 98786	1	Stelo Dx. compl.	R.H. slider assy	Montant D. compl.	Bein, Kpl. R.	Deslizable der. compl.	
<b>E&amp;M</b>	6	8000 91506	1	Stelo Dx. compl.	R.H. slider assy	Montant D. compl.	Bein, Kpl. R.	Deslizable der. compl.	
<b>C</b>	7	8000 A3191	1	Kit gancio partenza	Kit starting hook	Kit crochet pour départ	Abfahrthacken	Gancho por salida	
<b>N</b>	8	(a), (b)	2	Bussola	Bushing	Douille	Buchse	Manguito	
<b>N</b>	9		2	Scodellino	Cup	Cuvette	Teller	Cubeta	
<b>N</b>	10	(a), (c)	2	Anello di tenuta	Seal ring	Bague de retenue	Dichtring	Anillo de retención	
<b>N</b>	11	(c)	2	Anello di fermo	Stop ring	Bague d'arrêt	Haltering	Anillo de retención	
<b>N</b>	12	(a), (c)	2	Raschiapolvere	Dust scraper	Racloir poudre	Pulverabschaber	Rascador de polvo	
	13	8000 91474	2	Portastelo completo	Pipe assy	Groupe tuyau compl.	Rohrgruppe Kpl	Grupo tubo compl.	
<b>N</b>	14		2	Vite	Screw	Vis	Schraube	Tornillo	
<b>N</b>	15		2	Sfera	Ball	Bille	Kugel	Esfera	
<b>N</b>	16		2	Molla per sfera	Spring	Ressort	Feder	Resorte	
<b>N</b>	17		2	Grano filettato	Dowel	Grain	Stift	Pasadòr	
<b>N</b>	18	(a)	2	Anello OR	O-Ring	Bague OR	O-Ring	Anillo OR	
	19	8000 91479	2	Gruppo registro	Adjuster set	Groupe reglage	Reglergruppe	Grupo regulaciòn	
	20	8000 77373	2	Scodellino	Cup	Cuvette	Teller	Cubeta	
<b>W</b>	21	8000 91610	1	Kit molla ( k= 4,5 N/mm)	Spring ( k= 4,5 N/mm)	Ressort ( k= 4,5 N/mm)	Feder ( k= 4,5 N/mm)	Resorte ( k= 4,5 N/mm)	
<b>C</b>	21	8000 98789	1	Kit molla ( k= 4,8 N/mm)	Spring ( k= 4,8 N/mm)	Ressort ( k= 4,8 N/mm)	Feder ( k= 4,8 N/mm)	Resorte ( k= 4,8 N/mm)	
<b>M</b>	21	8000 98803	1	Kit molla ( k= 5,0 N/mm)	Spring ( k= 5,0 N/mm)	Ressort ( k= 5,0 N/mm)	Feder ( k= 5,0 N/mm)	Resorte ( k= 5,0 N/mm)	
<b>W</b>	22	8000 98552	2	Gruppo pompante compl.	Damping element compl.	Amortissement compl.	Schwingungsdämpfer Kpl.	Bombedora compl.	
<b>C</b>	22	8000 98792	2	Gruppo pompante compl.	Damping element compl.	Amortissement compl.	Schwingungsdämpfer Kpl.	Bombedora compl.	

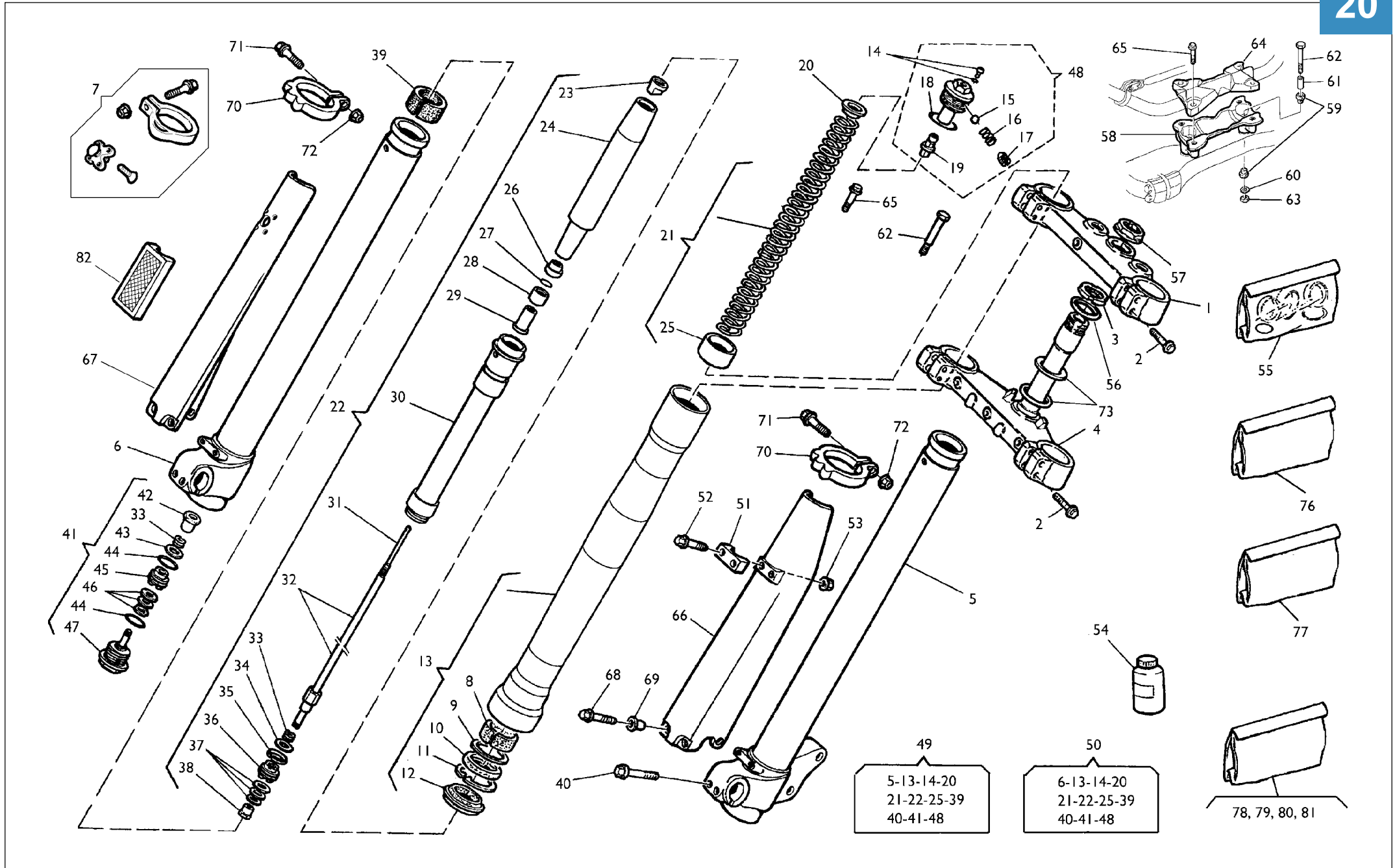





TC-TE 250- 450,  
SM 400R-450R/ 2004

TAVOLA  
DRAWING  
TABLE  
BILD  
TABLA

20

SOSPENSIONE ANTERIORE - FRONT FORK ASSEMBLY  
SUSPENSION AVANT - VORDERTELESKOPGABEL  
SUSPENSION DELANTERA

Note Notes Notas	Pos. No. N. Index Pos.	N. Cod. Code No. Nr. Code Code Nr N. Cod.	Q.tà Q.ty Q.te M.ge C.ad	DENOMINAZIONE	NAME	DESIGNATION	BESHREIBUNG	DENOMINACION	Validità Validity Validité Gültig Validez
<b>M</b>	22	8000 96645	2	Gruppo pompante compl.	Damping element compl.	Amortissement compl.	Schwingungsdämpfer Kpl.	Bombedora compl.	
<b>N</b>	23		2	Dado	Nut	Ecrou	Mutter	Tuerca	
<b>N</b>	24		2	Guidamolla	Spring guide	Guide ressort	Federführung	Guia resorte	
<b>N</b>	25		2	Tubetto	Pipe	Tuyau	Rohr	Tube	
<b>N</b>	26		2	Dado	Nut	Ecrou	Mutter	Tuerca	
<b>N</b>	27		2	Anello SEEGER	SEEGER ring	Anneau SEEGER	SEEGER Ring	Anillo SEEGER	
<b>N</b>	28		2	Tampone di fondo	Pad	Tampon	Stopfen	Tampòn	
<b>N</b>	29		2	Distanziale	Spacer	Entretoise	Distanzstück	Separadòr	
<b>N</b>	30		2	Custodia	Housung	Cage	Korb	Custodia	
<b>N</b>	31		2	Asta interna	Internal rod	Barre	Stange	Varilla	
<b>N</b>	32		2	Ass. asta	Rod assy	Barre compl.	Stange Kpl	Grupo varilla	
<b>N</b>	33		4	Molla	Spring	Ressort	Feder	Resorte	
<b>N</b>	34	(d)	2	Lamella	Plate	Lamelle	Plättchen	Laminilla	
<b>N</b>	35	(a)	2	Segmento	Circlip	Segment	Colbenring	Segmento	
<b>N</b>	36		2	Pistone estensione	R.H. piston	Piston D.	Kolbe R.	Pistón der.	
<b>N</b>	37	(d)	6	Lamella	Plate	Lamelle	Plättchen	Laminilla	
<b>N</b>	38		2	Dado	Nut	Ecrou	Mutter	Tuerca	
<b>N</b>	39	(a), (b)	2	Bussola	Bushing	Douille	Buchse	Manguito	
	40	8000 62729	4	Vite (M6x25 mm)	Screw (M6x25 mm)	Vis (M6x25 mm)	Schraube (M6x25 mm)	Tornillo (M6x25 mm)	
<b>W</b>	41	8000 98781	2	Ass. valvola di fondo	Valve	Soupape	Ventil	Válvula	
<b>C</b>	41	8000 95260	2	Ass. valvola di fondo	Valve	Soupape	Ventil	Válvula	
<b>M</b>	41	8000 96647	2	Ass. valvola di fondo	Valve	Soupape	Ventil	Válvula	
<b>N</b>	42		2	Dado	Nut	Ecrou	Mutter	Tuerca	
<b>N</b>	43	(d)	2	Lamella	Plate	Lamelle	Plättchen	Laminilla	
<b>N</b>	44	(a)	2	Anello OR	O-Ring	Bague OR	O-Ring	Anillo OR	
<b>N</b>	45		2	Pistone compressione	Piston	Piston	Kolbe	Pistón	
<b>N</b>	46	(d)	6	Lamella	Plate	Lamelle	Plättchen	Laminilla	
<b>N</b>	47		2	Valvola	Valve	Soupape	Ventil	Valvula	
	48	8000 91480	2	Gruppo tappo	Plug assy	Groupe bouchon	Verschlussgruppe Kpl	Grupo tapón	
<b>W</b>	49	8A00 97015	1	Gamba Sx. compl.	L.H. fork leg assy	Fourche complete G.	Telegabel Kpl. L.	Horquilla izrda. compl.	
<b>C</b>	49	8000 96839	1	Gamba Sx. compl.	L.H. fork leg assy	Fourche complete G.	Telegabel Kpl. L.	Horquilla izrda. compl.	
<b>E&amp;M</b>	49	8000 95699	1	Gamba Sx. compl.	L.H. fork leg assy	Fourche complete G.	Telegabel Kpl. L.	Horquilla izrda. compl.	
<b>M</b>	49	8A00 95699	1	Gamba Sx. compl.	L.H. fork leg assy	Fourche complete G.	Telegabel Kpl. L.	Horquilla izrda. compl.	

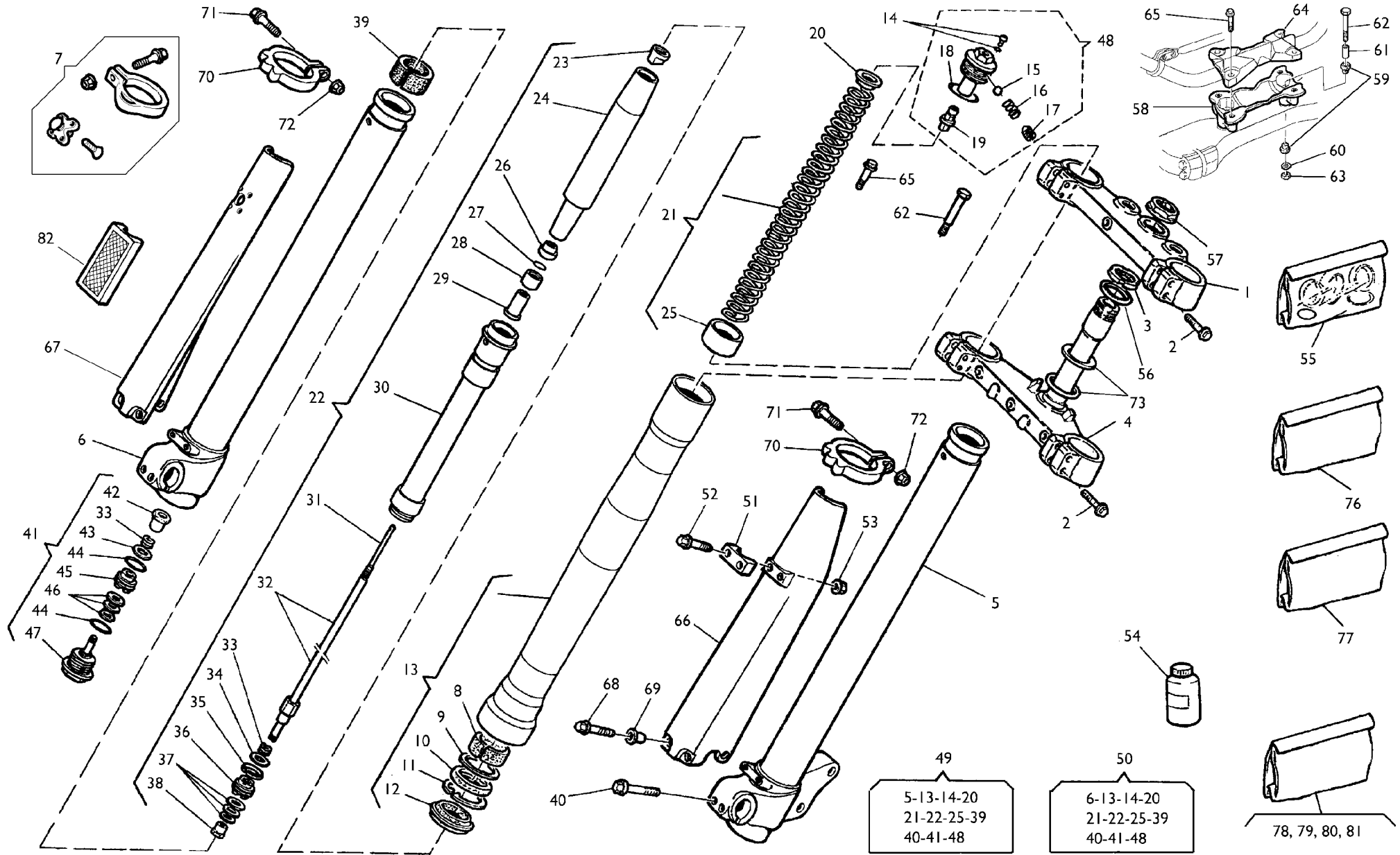



**TC-TE 250- 450,  
SM 400R-450R/ 2004**

TAVOLA  
DRAWING  
TABLE  
BILD  
TABLA

**20**

**SOSPENSIONE ANTERIORE - FRONT FORK ASSEMBLY  
SUSPENSION AVANT - VORDERTELESKOPGABEL  
SUSPENSION DELANTERA**

Note Notes Notas	Pos. No. Index Pos.	N. Cod. Code No. Nr. Code Code Nr N. Cod.	Q.tà Q.ty Q.te M.ge C.ad	DENOMINAZIONE	NAME	DESIGNATION	BESHREIBUNG	DENOMINACION	Validità Validity Validité Gültig Validez
<b>W</b>	50	8A00 97016	1	Gamba Dx. compl.	R.H. fork leg assy	Fourche complete D.	Telegabel Kpl. R.	Horquilla derech. compl.	
<b>C</b>	50	8000 96840	1	Gamba Dx. compl.	R.H. fork leg assy	Fourche complete D.	Telegabel Kpl. R.	Horquilla derech. compl.	
<b>E&amp;M</b>	50	8000 95698	1	Gamba Dx. compl.	R.H. fork leg assy	Fourche complete D.	Telegabel Kpl. R.	Horquilla derech. compl.	
<b>M</b>	50	8A00 95698	1	Gamba Dx. compl.	R.H. fork leg assy	Fourche complete D.	Telegabel Kpl. R.	Horquilla derech. compl.	
<b>WC</b>	51	8000 A0633	1	Piastrina	Plate	Plaquette	Plättchen	Placa	
<b>M</b>	51	8000 A0633	1	Piastrina (codice colore E)	Plate (color code E)	Plaquette (code couleur E)	Plättchen (Code Farbe E)	Placa (còdigo colòr E)	
<b>M</b>	51	80A0 A0633	1	Piastrina (codice colore G)	Plate (color code G)	Plaquette (code couleur G)	Plättchen (Code Farbe G)	Placa (còdigo colòr G)	
	52	8A00 67997	2	Vite	Screw	Vis	Schraube	Tornillo	
	53	8000 61355	2	Dado	Nut	Ecrou	Mutter	Tueca	
<b>R</b>	54	8000 80260	1	Olio forcella	Front fork oil	Huile fourche avant	Öl für die Vordergabel	Aceite horquilladelantera	
	55	8000 91519	1	Gruppo guarnizioni	Gasket set	Groupe garnitures	Dichtungssatz	Grupo juntas	
<b>WM</b>	56	8A00 65503	2	Rosetta piana	Washer	Rondelle	Scheibe	Arandela	
<b>C</b>	56	8000 87736	2	Rosetta piana	Washer	Rondelle	Scheibe	Arandela	
<b>WM</b>	57	8000 69315	1	Dado	Nut	Ecrou	Mutter	Tuerca	
<b>C</b>	57	8A00 69315	1	Dado	Nut	Ecrou	Mutter	Tuerca	
	58	8000 98237	1	Mozzetto inferiore	Hub	Moyeau	Radnabe	Cbo	
	59	8000 60233	4	Gommino	Rubber pad	Pièce caoutchouc	Gummistück	Junta de goma	
	60	8000 60234	2	Rosetta piana	Washer	Rondelle	Scheibe	Arandela	
	61	8000 53155	2	Distanziale	Spacer	Entretoise	Distanzstück	Separador	
	62	60N1 01219	2	Vite (M10x65 mm)	Screw(M10x65 mm)	Vis(M10x65 mm)	Schraube(M10x65 mm)	Tornillo(M10x65 mm)	
	63	8000 61314	2	Dado	Nut	Ecrou	Mutter	Tuerca	
	64	8000 98118	2	Mozzetto superiore	Hub	Moyeau	Radnabe	Cubo	
	65	8C00 69056	4	Vite (M8x30 mm)	Screw (M8x30 mm)	Vis (M8x30 mm)	Schraube (M8x30 mm)	Tornillo (M8x30 mm)	
<b>M</b>	66	80A0 95696	1	Protezione steli Sx. (codice colore E)	Guard L.H. (color code E)	Protection D. (code couleur E)	Schutz L. (Code Farbe E)	Protección izq. (còdigo colòr E)	
<b>M</b>	66	8000 95696	1	Protezione steli Sx. (codice colore G)	Guard L.H. (color code G)	Protection D. (code couleur G)	Schutz L. (Code Farbe G)	Protección izq. (còdigo colòr G)	
<b>WC</b>	66	80G0 69337	1	Protezione steli Sx.	Guard L.H.	Protection D.	Schutz L.	Protección izq.	
<b>M</b>	67	80G0 69338	1	Protezione steli Dx. (codice colore E)	Guard R.H. (color code E)	Protection G. (code couleur E)	Schutz R. (Code Farbe E)	Protección der. (còdigo colòr E)	
<b>M</b>	67	80C0 69338	1	Protezione steli Dx. (codice colore G)	Guard R.H. (color code G)	Protection G. (code couleur G)	Schutz R. (Code Farbe G)	Protección der. (còdigo colòr G)	
<b>WC</b>	67	80G0 69338	1	Protezione steli Dx.	Guard R.H.	Protection G.	Schutz R.	Protección der.	

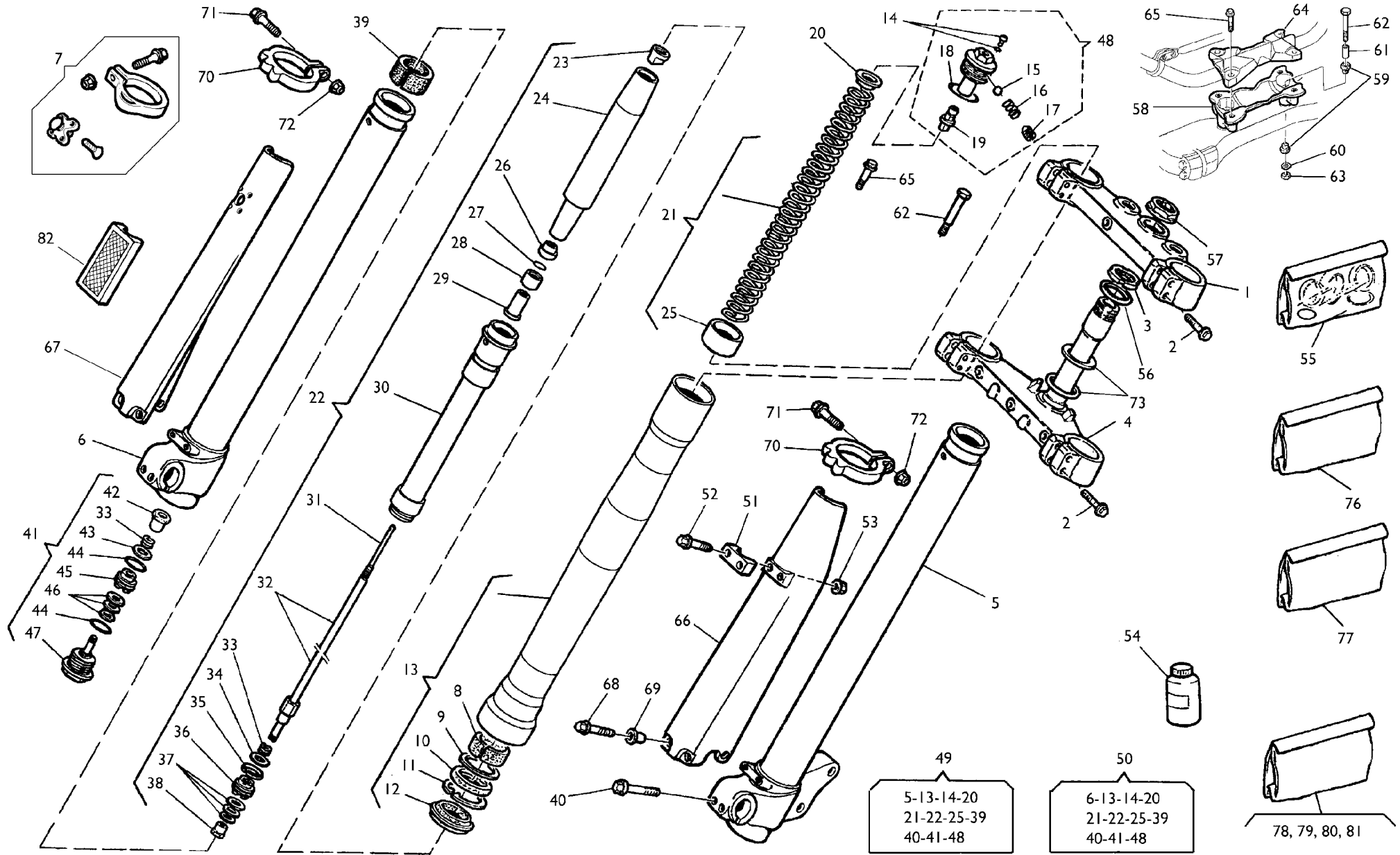



TC-TE 250- 450,  
SM 400R-450R/ 2004

TAVOLA  
DRAWING  
TABLE  
BILD  
TABLA

20

SOSPENSIONE ANTERIORE - FRONT FORK ASSEMBLY  
SUSPENSION AVANT - VORDERTELESKOPGABEL  
SUSPENSION DELANTERA

Note Notes Markes Notas	Pos. No. N. Index Pos.	N. Cod. Code No. Nr. Code Code Nr N. Cod.	Q.tà Q.ty M.ge C.ad	DENOMINAZIONE	NAME	DESIGNATION	BESHREIBUNG	DENOMINACION	Validità Validity Validité Gültig Validez
	68	8000 67997	6	Vite	Screw	Vis	Schraube	Tornillo	
	69	8000 69282	6	Bussola	Bush	Douille	Buchse	Manguito	
	70	8000 93283	2	Anello	Ring	Bague	Ring	Anilo	
	71	8B00 66525	2	Vite	Screw	Vis	Schraube	Tornillo	
	72	8000 56443	2	Dado	Nut	Ecrou	Mutter	Tuerca	
<b>C</b>	73	8000 87745	2	Guarnizione di tenuta	Gasket	Garniture	Dichtung	Guarnición	
	76	8000 97750	1	Kit boccole	Bush kit	Kit douille	Buchsekit	Kit manguito	
	77	8000 97749	1	Kit anelli di tenuta	Seal ring kit	Kit bague de retenue	Dichtringkit	Kit anillo de retención	
	78	8000 98782	1	Kit lamelle (0,1 mm)	Plate kit (0,1 mm)	Kit lamelle (0,1 mm)	Plättchenkit (0,1 mm)	Kit Laminilla (0,1 mm)	
	79	8000 98783	1	Kit lamelle (0,2 mm)	Plate kit (0,2 mm)	Kit lamelle (0,2 mm)	Plättchenkit (0,2 mm)	Kit Laminilla (0,2 mm)	
	80	8000 98784	1	Kit lamelle (0,3 mm)	Plate kit (0,3 mm)	Kit lamelle (0,3 mm)	Plättchenkit (0,3 mm)	Kit Laminilla (0,3 mm)	
	81	8000 98785	1	Kit lamelle (0,4 mm)	Plate kit (0,4 mm)	Kit lamelle (0,4 mm)	Plättchenkit (0,4 mm)	Kit Laminilla (0,4 mm)	
<b>Y</b>	82	80B0 73832	2	Catadiottro ambra (AUS)	Reflector amber (AUS)	Catadioptrique ambre (AUS)	Rückstrahler Amber (AUS)	Catafaros àambar (AUS)	
<b>CU</b>	82	8000 73832	2	Catadiottro rosso (CDN)	Reflector red (CDN)	Catadioptrique rouge (CDN)	Rückstrahler Rot (CDN)	Catafaros rojo (CDN)	
<b>CU</b>	82	80B0 73832	2	Catadiottro ambra (CDN)	Reflector amber (CDN)	Catadioptrique ambre (CDN)	Rückstrahler Amber (CDN)	Catafaros àambar (CDN)	
<b>a</b>				Forniti anche in gruppo pos. 55	Supplied in bag ref. N° 55	Son fournies en unités pos. 55	Sind im Umschlag Bez. Nr 55	Provisto en grupo pos. 55	
<b>b</b>				Forniti anche in gruppo pos. 76	Supplied in bag ref. N° 76	Son fournies en unités pos. 76	Sind im Umschlag Bez. Nr 76	Provisto en grupo pos. 76	
<b>c</b>				Forniti anche in gruppo pos. 77	Supplied in bag ref. N° 77	Son fournies en unités pos. 77	Sind im Umschlag Bez. Nr 77	Provisto en grupo pos. 77	
<b>d</b>				Forniti anche in gruppo pos. 78, 79, 80, 81	Supplied in bag ref. N° 78, 79, 80, 81	Son fournies en unités pos. 78, 79, 80, 81	Sind im Umschlag Bez. Nr 78, 79, 80, 81	Provisto en grupo pos. 78, 79, 80, 81	
<b>&amp;</b>				Fornire in abbinamento a part. 8A0094696 Tav.30A pos.10	Supply unitedly to part 8A0094696 Draw.30A No.10	Fournir ensemble à part. 8A0094696 Table 30A N.10	Wird Paaren mit Teile 8A0094696 Bild 30A Index 10	Equipar acoplado al part. 8A0094696 Tab. 30A pos.10	

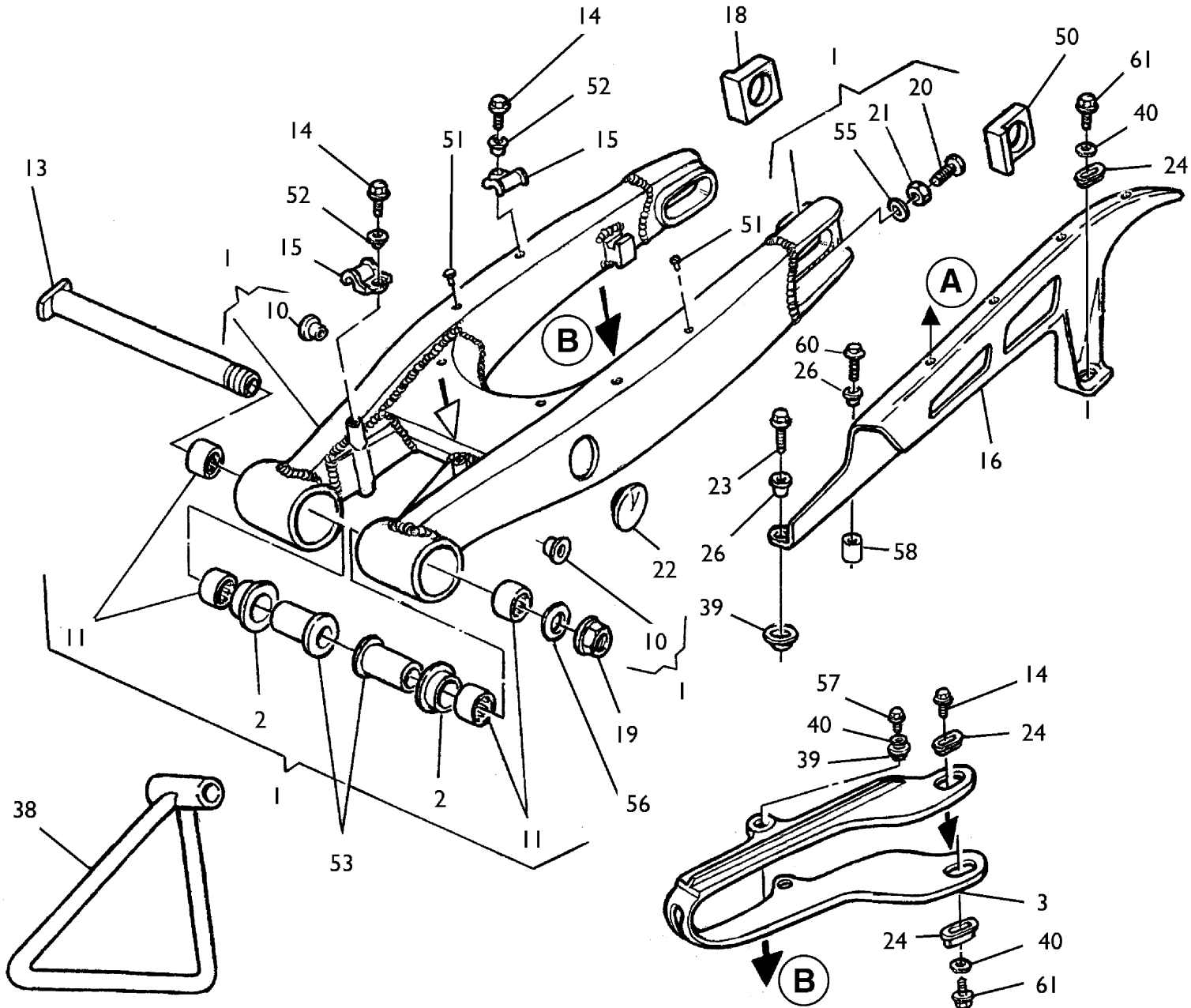

**(AUS)**

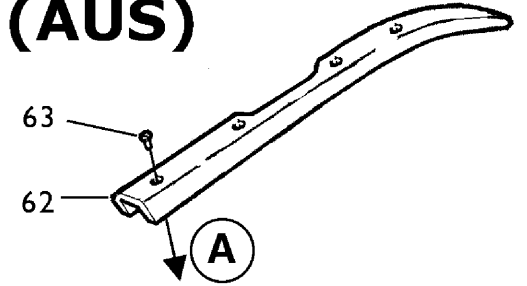

**TC**

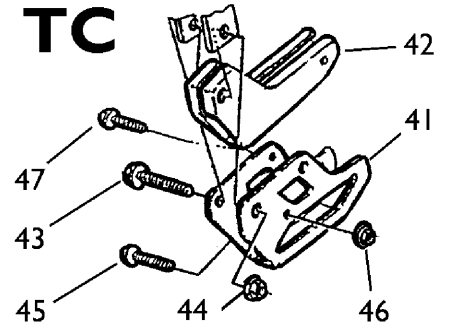

**TE-SMR**

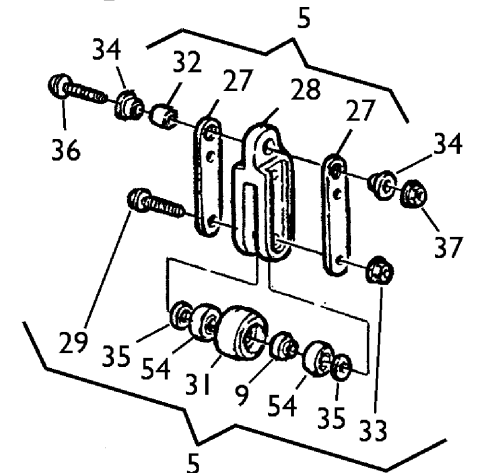





**TC-TE 250- 450,  
SM 400R-450R/ 2004**

TAVOLA  
DRAWING  
TABLE  
BILD  
TABLA

**21**

**FORCELLONE POSTERIORE-REAR SWING ARM-FOURCHE ARRIERE-  
HINTERGABEL-HORQUILLA TRASERA**

Note Notes Markes Notas	Pos. No. N. Index Pos.	N. Cod. Code No. Nr. Code Code Nr N. Cod.	Q.tà Q.ty Q.te M.ge C.ad	DENOMINAZIONE	NAME	DESIGNATION	BESHREIBUNG	DENOMINACION	Validità Validity Validité Gültig Validez
<b>Y</b>	1	8000 99616	1	Forcellone completo	Swing arm assy.	Fourche complete	Gabel, Kpl.	Horquilla compl.	
<b>C</b>	1	8000 A2817	1	Forcellone completo	Swing arm assy.	Fourche complete	Gabel, Kpl.	Horquilla compl.	
	2	8000 71622	2	Bussola	Bushing	Douille	Buchse	Manguito	
	3	8000 99619	1	Pattino catena	Chain slider	Glissière	Gleitbahn	Plato cadena	
<b>Y</b>	5	8000 72873	1	Ass. guidacatena (TE, SMR)	Chain guide (TE, SMR)	Guide chaine (TE, SMR)	Kettenführung (TE, SMR)	Guja cadena (TE, SMR)	
<b>Y</b>	9	8000 65412	1	Distanziale	Spacer	Entretoise	Distanzstück	Separador	
	10	8000 87810	1	Bussola Sp.16 mm (lato disco)	R.H. bushing (th.16 mm)	Douille D. (épaisseur 16 mm)	Buchse R. (Dicken 16 mm)	Manguito der. (esp.16 mm)	
	10	8A00 87810	1	Bussola Sp.13 mm (lato corona)	L.H. bushing (th.13 mm)	Douille G. (épaisseur 13 mm)	Buchse L. (Dicken 13 mm)	Manguito iz. (esp.13 mm)	
	11	8000 76283	4	Gabbia a rullini (ø22xø28x18 mm)	Needle cage (ø22xø28x18 mm)	Cage à aiguilles (ø22xø28x18 mm)	Nadelkaefig (ø22xø28x18 mm)	Jaula de agujas del cojinete (ø22xø28x18 mm)	
	13	8000 71620	1	Perno forcellone	Fork pin	Pivot fourche	Gabelbolzen	Perno horquilla	
	14	8000 20536	1	Vite posteriore (Ø4,8x13 mm)	Rear screw (Ø4,8x13 mm)	Vis arriere(Ø4,8x13 mm)	Hinterschraube (Ø4,8x13 mm)	Tornillo trasero (Ø4,8x13 mm)	
	14	8000 67997	1	Vite anteriore (M5x12 mm)	Front screw (M5x12 mm)	Vis avant (M5x12 mm)	Vorderschraube (M5x12 mm)	Tornillo delantero (M5x12 mm)	
	15	80A0 73456	2	Guidacavo	Cable guide	Guide câble	Kabelführung	Guía-cable	
<b>XY</b>	16	8AA0 73909	1	Copricatena	Chain guard	Carter de chaine	Kettenkasten	Cubre-cadena	
	18	8000 96944	2	Tendicatena DX	Chain adjuster R.	Tendeur de chaine D.	Kettenspanner R.	Tensor de cadena D.	
	19	8000 71623	1	Dado	Nut	Ecrou	Mutter	.Tuerca	
	20	8C00 61121	2	Vite	Screw	Vis	Schraube	Tornillo	
	21	8000 17810	2	Dado	Nut	Ecrou	Mutter	Tuerca	
	22	80A0 74388	2	Tappo	Plug	Bouchon	Verschluss	Tapón	
<b>XY</b>	23	8A00 67997	1	Vite (M5x16 mm)	Screw (M5x16 mm)	Vis (M5x16 mm)	Schraube (M5x16 mm)	Tornillo (M5x16 mm)	
	24	8000 59289	3	Scodellino	Cup	Cuvette	Teller	Cubeta	
<b>XY</b>	26	8A00 69282	2	Bussola	Bushing	Douille	Buchse	Manguito	
<b>YXB</b>	27	8000 72875	2	Piastra d'attacco	Plate	Plaque	Platte	Placa	
<b>Y</b>	28	8000 72874	1	Guidacatena	Chain guide	Guide-chaine	Kettenführung	Guía-cadena	
<b>Y</b>	29	8000 62731	2	Vite (M6x45 mm)	Screw (M6x45 mm)	Vis (M6x45 mm)	Schraube (M6x45 mm)	Tornillo (M6x45 mm)	
<b>Y</b>	31	8000 65411	1	Rullo	Roller	Aiguille	Rolle	Rodillo	
<b>Y</b>	32	1515 50601	1	Bussola	Bushing	Douille	Buchse	Manguito	
<b>Y</b>	33	8000 44240	2	Dado	Nut	Ecrou	Mutter	Tuerca	
<b>Y</b>	34	8A00 66661	2	Bussola	Bushing	Douille	Buchse	Manguito	
<b>Y</b>	35	8000 45495	2	Boccola di spallamento	Washer	Rondelle	Scheibe	Arandela	
<b>Y</b>	36	8000 62795	1	Vite	Screw	Vis	Schraube	Tornillo	

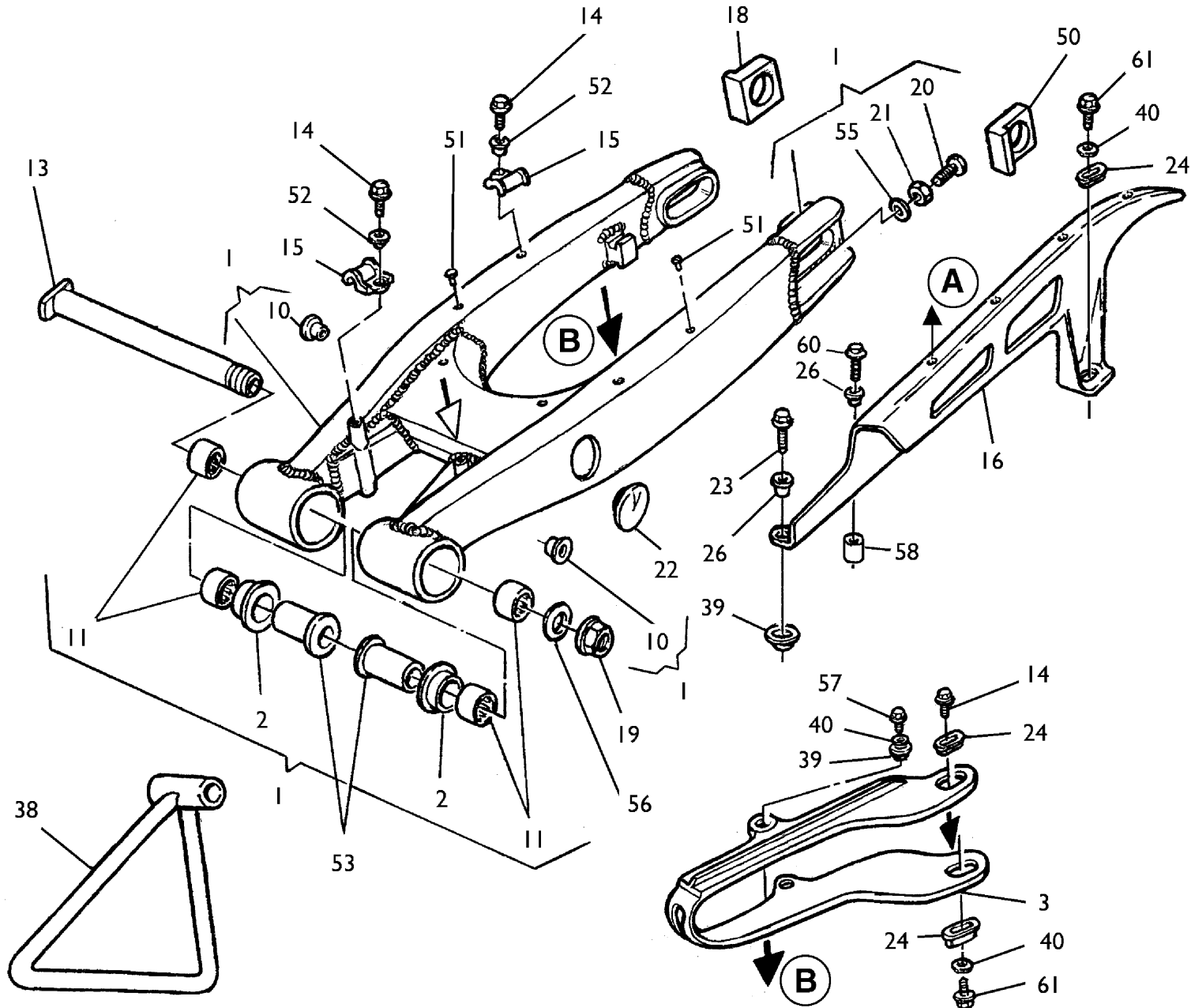

**(AUS)**

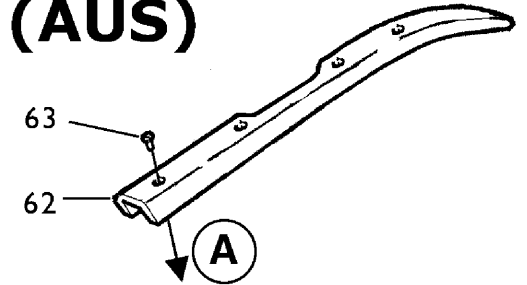

**TC**

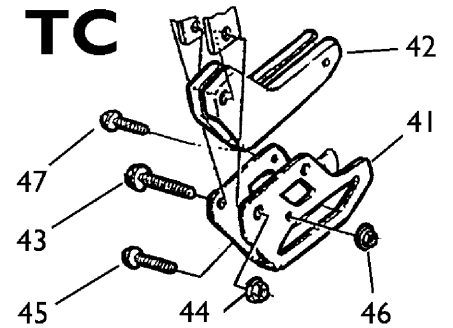

**TE-SMR**

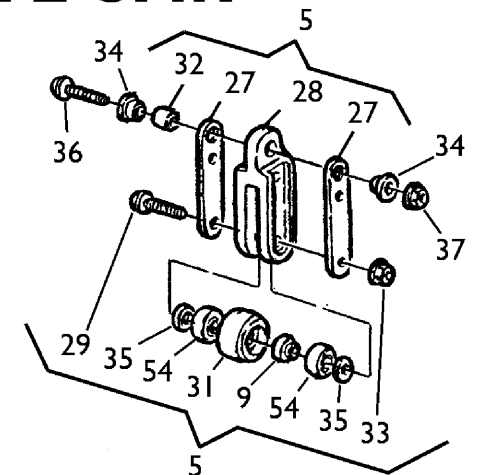



**TC-TE 250- 450,  
SM 400R-450R/ 2004**

TAVOLA  
DRAWING  
TABLE  
BILD  
TABLA

**21**

**FORCELLONE POSTERIORE-REAR SWING ARM-FOURCHE ARRIERE-  
HINTERGABEL-HORQUILLA TRASERA**

Note Notes Marke Notas	Pos. No. N. Index Pos.	N. Cod. Code No. Nr. Code Code Nr N. Cod.	Q.tà Q.ty Q.te M.ge C.ad	DENOMINAZIONE	NAME	DESIGNATION	BESHREIBUNG	DENOMINACION	Validità Validity Validité Gültig Validez
<b>Y</b>	37	8000 43928	1	Dado	Nut	Ecrou	Mutter	Tuerca	
<b>CD</b>	38	8000 74016	1	Gamba laterale	Side stand	Bequille lat.	Seitenstander	Horquilla lateral	
	39	8000 75166	4	Scodellino	Cup	Cuvette	Teller	Cubeta	
	40	8000 36137	4	Rosetta piana	Washer	Rondelle	Scheibe	Arandela	
<b>MCU</b>	41	8000 72869	1	Staffa	Bracket	Entier	Buegel	Brida	
<b>MCU</b>	42	8000 72868	1	Guidacatena	Chain guide	Guidechaine	Kettenführung	Guiacadena	
<b>MCU</b>	43	8000 62795	1	Vite (M8x50 mm)	Screw (M8x50 mm)	Vis (M8x50 mm)	Schraube (M8x50 mm)	Tornillo (M8x50 mm)	
<b>MCU</b>	44	8000 43928	1	Dado	Nut	Ecrou	Mutter	Tuerca	
<b>MCU</b>	45	8000 62731	1	Vite (M6x45 mm)	Screw (M6x45 mm)	Vis (M6x45 mm)	Schraube (M6x45 mm)	Tornillo (M6x45 mm)	
<b>MCU</b>	46	8000 44240	1	Dado	Nut	Ecrou	Mutter	Tuerca	
<b>MCU</b>	47	8000 62725	1	Vite (M6x10 mm)	Screw (M6x10 mm)	Vis (M6x10 mm)	Schraube (M6x10 mm)	Tornillo (M6x10 mm)	
	50	8000 96941	1	Tendicatena SX	Chain adjuster L.	Tendeur de chaine G.	Kettenspanne L.	Tensor de cadena l.	
	51	8000 75160	4	Rivetto	Rivet	Rivet	Niet	Remache	
	52	8000 69282	2	Bussola	Bushing	Douille	Buchse	Manguito	
	53	8000 71621	2	Bussola	Bushing	Douille	Buchse	Manguito	
<b>Y</b>	54	8000 63312	2	Cuscinetto (ø8xØ22x7 mm)	Bearing (ø8xØ22x7 mm)	Roulement (ø8xØ22x7 mm)	Lager (ø8xØ22x7 mm)	Cojinete (ø8xØ22x7 mm)	
	55	8000 08536	2	Rosetta piana	Washer	Rondelle	Scheibe	Arandela	
	56	8000 32388	1	Rosetta	Washer	Rondelle	Scheibe	Arandela	
	57	8000 67997	2	Vite	Screw	Vis	Schraube	Tornillo	
	58	8000 97025	1	Bussola	Bushing	Douille	Buchse	Manguito	
	60	60N1 01059	1	Vite (M5x35 mm)	Screw (M5x35 mm)	Vis (M5x35 mm)	Schraube (M5x35 mm)	Tornillo (M5x35 mm)	
	61	8000 20536	3	Vite (Ø4,8x13 mm)	Screw (Ø4,8x13 mm)	Vis (Ø4,8x13 mm)	Schraube (Ø4,8x13 mm)	Tornillo (Ø4,8x13 mm)	
<b>Y</b>	62	8000 A2352	1	Prolunga per guidacatena (AUS)	Chain guide extension (AUS)	Guidechaine extension (AUS)	Kettenführungverlängerung (AUS)	Prolonga por guiacadena (AUS)	
<b>Y</b>	63	8000 81628	4	Vite (AUS)	Screw (AUS)	Vis (AUS)	Schraube (AUS)	Tornillo (AUS)	

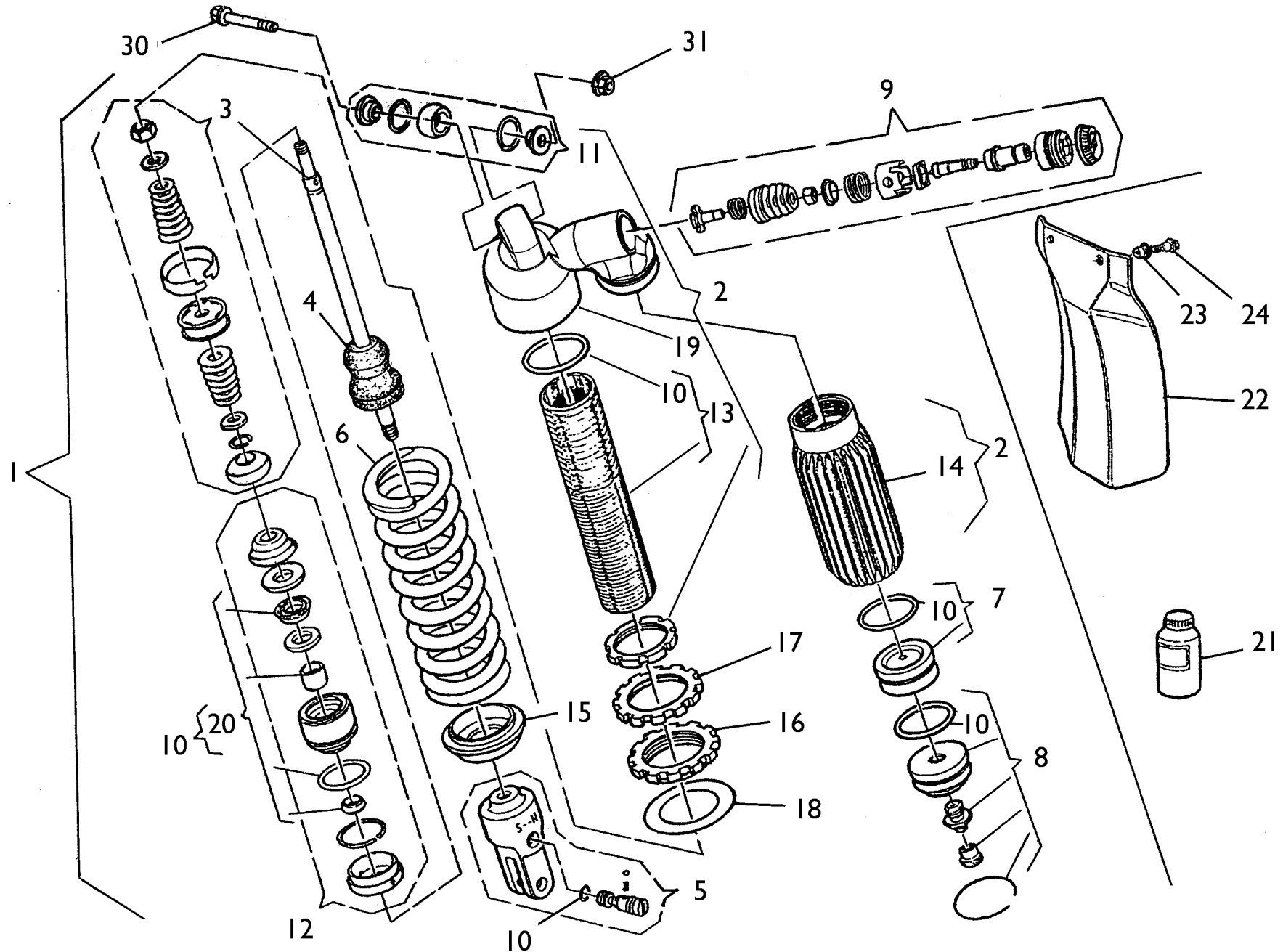



TC-TE 250- 450,  
SM 400R-450R/ 2004

TAVOLA  
DRAWING  
TABLE  
BILD  
TABLA

22

AMMORTIZZATORE POSTERIORE-REAR SUSPENSION  
SUSPENSION ARRIERE-HINTERHAUFHANGUNG  
SUSPENSION TRASERA

Note Notes Notas	Pos. No. Index Pos.	N. Cod. Code No. Nr. Code Code Nr N. Cod.	Q.tà Q.ty Q.te M.ge C.ad	DENOMINAZIONE	NAME	DESIGNATION	BESHREIBUNG	DENOMINACION	Validità Validity Validité Gültig Validez
	1	8000 99620	1	Ammort. compl. (TE 250)	Shock-absorber (TE 250)	Ammortisseur (TE 250)	Stossdampfer (TE 250)	Amortigüador (TE 250)	
	1	8000 A2816	1	Ammort. compl. (TC 250)	Shock-absorber (TC 250)	Ammortisseur (TC 250)	Stossdampfer (TC 250)	Amortigüador (TC 250)	
	1	8000 A0375	1	Ammort. compl. (TE 450)	Shock-absorber (TE 450)	Ammortisseur (TE 450)	Stossdampfer (TE 450)	Amortigüador (TE 450)	
	1	8000 A2819	1	Ammort. compl. (TC 450)	Shock-absorber (TC 450)	Ammortisseur (TC 450)	Stossdampfer (TC 450)	Amortigüador (TC 450)	
	1	8000 A0308	1	Ammort. compl. (SMR)	Shock-absorber (SMR)	Ammortisseur (SMR)	Stossdampfer (SMR)	Amortigüador (SMR)	
<b>W</b>	2	8000 A1503	1	Gruppo corpo	Damper case assy	Groupe corps ammortisseur	Stossdämpferkörper Kpl.	Corpo amortigüador compl.	
<b>M</b>	2	8000 98500	1	Gruppo corpo	Damper case assy	Groupe corps ammortisseur	Stossdämpferkörper Kpl.	Corpo amortigüador compl.	
<b>C</b>	2	8000 A3644	1	Gruppo corpo	Damper case assy	Groupe corps ammortisseur	Stossdämpferkörper Kpl.	Corpo amortigüador compl.	
	3	8000 A1504	1	Gruppo stelo (TE 250)	Rod assy (TE 250)	Groupe tige (TE 250)	Pumpenstückgruppe (TE 250)	Grupo espiga (TE 250)	
	3	8000 A3645	1	Gruppo stelo (TC 250)	Rod assy (TC 250)	Groupe tige (TC 250)	Pumpenstückgruppe (TC 250)	Grupo espiga (TC 250)	
	3	8000 A1505	1	Gruppo stelo (TE 450)	Rod assy (TE 450)	Groupe tige (TE 450)	Pumpenstückgruppe (TE 450)	Grupo espiga (TE 450)	
	3	8000 A3653	1	Gruppo stelo (TC 450)	Rod assy (TC 450)	Groupe tige (TC 450)	Pumpenstückgruppe (TC 450)	Grupo espiga (TC 450)	
	3	8000 A1506	1	Gruppo stelo (SMR)	Rod assy (SMR)	Groupe tige (SMR)	Pumpenstückgruppe (SMR)	Grupo espiga (SMR)	
	4	8000 91238	1	Tampone	Pad	Tampon	Stopfen	Tampòn	
<b>WC</b>	5	8000 A1507	1	Gruppo forcella	Fork assy	Groupe fourche	Gabelgruppe Kpl.	Grupo horquilla	
<b>M</b>	5	8000 98489	1	Gruppo forcella	Fork assy	Groupe fourche	Gabelgruppe Kpl.	Grupo horquilla	
	6	8000 98568	1	Molla (k=5,0 Kg/mm) (TE 250)	Spring (k=5,0 Kg/mm) (TE 250)	Ressort (k=5,0 Kg/mm) (TE 250)	Feder (k=5,0 Kg/mm) (TE 250)	Resorte (k=5,0 Kg/mm) (TE 250)	
	6	8000 98569	1	Molla (k=5,2 Kg/mm) (TC 250-TE 450)	Spring (k=5,2 Kg/mm) (TC 250-TE 450)	Ressort (k=5,2 Kg/mm) (TC 250-TE 450)	Feder (k=5,2 Kg/mm) (TC 250-TE 450)	Resorte (k=5,2 Kg/mm) (TC 250-TE 450)	
	6	8000 98504	1	Molla (k=5,4 Kg/mm) (TC 450)	Spring (k=5,4 Kg/mm) (TC 450)	Ressort (k=5,4 Kg/mm) (TC 450)	Feder (k=5,4 Kg/mm) (TC 450)	Resorte (k=5,4 Kg/mm) (TC 450)	
	6	8000 98520	1	Molla (k=6,4 Kg/mm) (SMR)	Spring (k=6,4 Kg/mm) (SMR)	Ressort (k=6,4 Kg/mm) (SMR)	Feder (k=6,4 Kg/mm) (SMR)	Resorte (k=6,4 Kg/mm) (SMR)	
	7	8000 98490	1	Diaframma	Diaphragm	Diaphragme	Biegeplatte	Diafragma	
	8	8000 A1508	1	Gruppo serbatoio	Tank assy	Groupe reservoir	Tankgruppe Kpl.	Grupo deposito compl.	
	9	8000 98492	1	Gruppo regolazione	Adjuster set	Groupe réglage	Reglergruppe Kpl.	Grupo regulacion	
<b>WM</b>	10	8000 A1509	1	Gruppo guarnizioni	Gasket set	Groupe garnitures	Dichtungssatz	Grupo juntas	
<b>C</b>	10	8000 A3647	1	Gruppo guarnizioni	Gasket set	Groupe garnitures	Dichtungssatz	Grupo juntas	
	11	8000 89089	1	Gruppo snodo	Ball joint assy	Groupe joint a rotule	Kugelgelenkgruppe Kpl.	Grupo articulaciòn esferica	
<b>WM</b>	12	8000 98494	1	Gruppo guida stelo	Guide rod assy	Groupe guide tige	Pumpenstückführungsgruppe	Grupo guja espiga	
<b>C</b>	12	8000 A3648	1	Gruppo guida stelo	Guide rod assy	Groupe guide tige	Pumpenstückführungsgruppe	Grupo guja espiga	
<b>W</b>	13	8000 A1510	1	Corpo ammortizzatore	Damper case	Corps ammortisseur	Stossdämpferkörper	Corpo amortigüador	

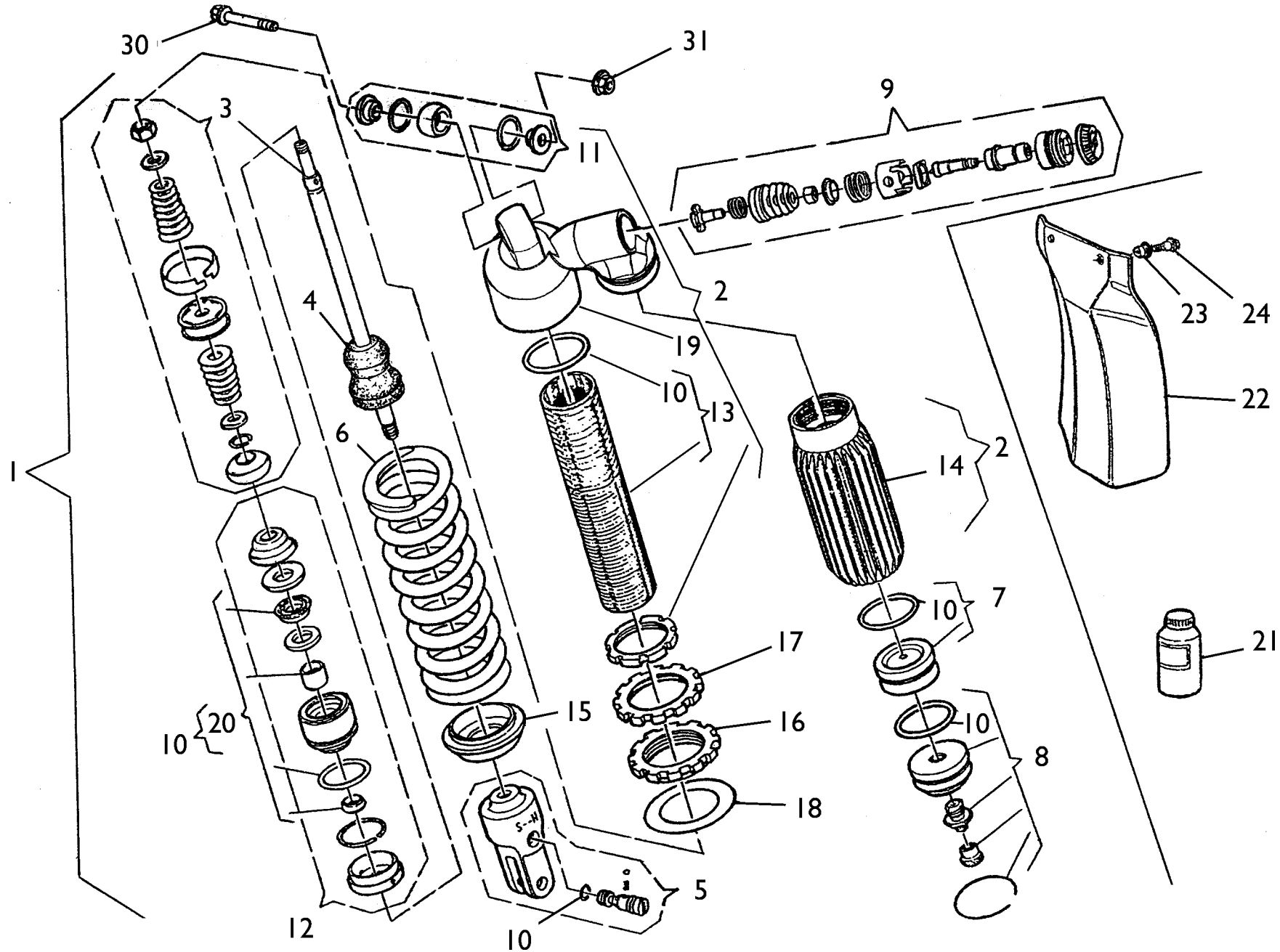





**TC-TE 250- 450,  
SM 400R-450R/ 2004**

TAVOLA  
DRAWING  
TABLE  
BILD  
TABLA

**22**

**AMMORTIZZATORE POSTERIORE-REAR SUSPENSION  
SUSPENSION ARRIERE-HINTERHAUFHANGUNG  
SUSPENSION TRASERA**

Note Notes Markes Notas	Pos. No. N. Index Pos.	N. Cod. Code No. Nr. Code Code Nr N. Cod.	Q.tà Q.ty Q.te M.ge C.ad	DENOMINAZIONE	NAME	DESIGNATION	BESHREIBUNG	DENOMINACION	Validità Validity Validité Gültig Validez
<b>M</b>	13	8000 98501	1	Corpo ammortizzatore	Damper case	Corps amortisseur	Stossdampferkörper	Corpo amortiguador	
<b>C</b>	13	8000 A3649	1	Corpo ammortizzatore	Damper case	Corps amortisseur	Stossdampferkörper	Corpo amortiguador	
	14	8000 98502	1	Serbatoio	Tank	Reservoir	Tank	Deposito	
<b>C</b>	14	8000 A3650	1	Serbatoio	Tank	Reservoir	Tank	Deposito	
	15	8000 98496	1	Fondello	Bottom	Fond	Bodenscheibe	Casquilo	
	16	8000 98497	1	Ghiera	Ring nut	Embout	Nutmutter	Virola	
	17	8000 98498	1	Controghiera	Ring nut	Embout	Nutmutter	Virola	
	18	8000 98499	1	Rosetta per molla	Washer	Rondelle	Scheibe	Arandela	
	19	8000 98503	1	Supporto serbatoio	Tank support	Support reservoir	Gastankhalterung	Soporte deposito	
<b>WM</b>	20	8000 98495	1	Gruppo guarnizioni per stelo	Rod gasket set	Jeu joints pour tige	Dichtungs für Pumpenstock	Serie juntas por espiga	
<b>C</b>	20	8000 A3651	1	Gruppo guarnizioni per stelo	Rod gasket set	Jeu joints pour tige	Dichtungs für Pumpenstock	Serie juntas por espiga	
<b>R</b>	21	8000 88231	1	Olio ammortizzatore	Shock-absorber oil	Huile amortisseur	Öl für Stossdampfer	Aceite amortiguador	
	22	80A0 69551	1	Protezione ammortizzatore	Guard	Protection	Schutz	Protección	
	23	8000 69429	4	Bussola	Bushing	Douille	Buchse	Manguito	
	24	8000 62726	4	Vite	Screw	Vis	Schraube	Tornillo	
	30	8A00 62797	1	Vite (M10x50 mm)	Screw (M10x50 mm)	Vis (M10x50 mm)	Schraube (M10x50 mm)	Tornillo (M10x50 mm)	
	31	8000 42022	1	Dado	Nut	Ecrou	Mutter	Tuerca	

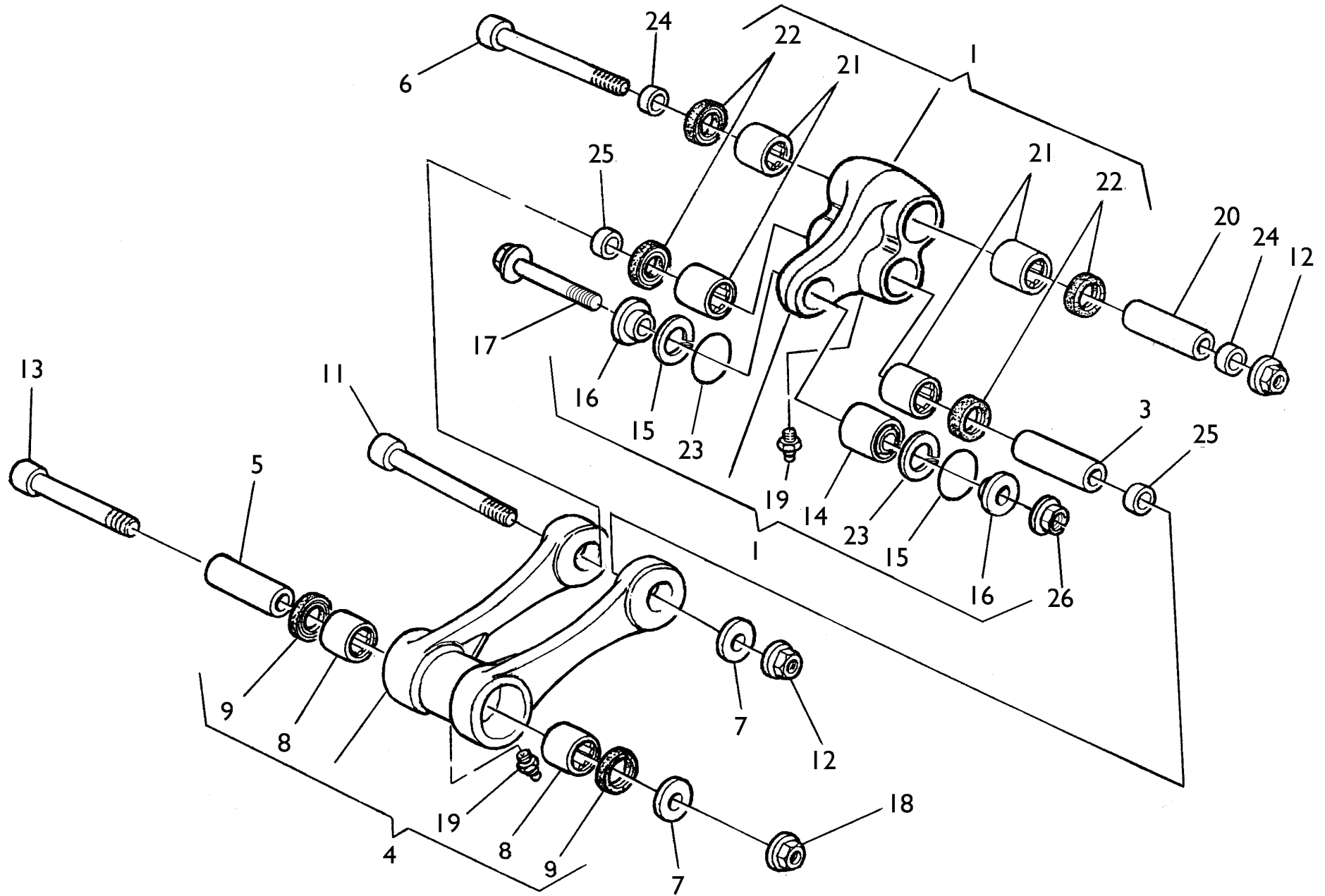

Note Notes Notas	Pos. No. Index Pos.	N. Cod. Code No. Nr. Code Code Nr N. Cod.	Q.tà Q.ty Q.te M.ge C.ad	DENOMINAZIONE	NAME	DESIGNATION	BESHREIBUNG	DENOMINACION	Validità Validity Validité Gültig Validez
	1	8000 96923	1	Assieme bilanciare	Rocking lever assy	Balancier compl.	Schwinge Kpl.	Balancines compl.	
	3	8000 86176	1	Spinotto	Gudgeon	Axe	Bolzen	Perno	
	4	8A00 97054	1	Tirante completo	Tie rod	Tirant	Spannstange	Tirante	
<b>A</b>	4	8000 97054	1	Tirante completo	Tie rod	Tirant	Spannstange	Tirante	
	5	8000 97050	1	Spinotto	Gudgeon	Axe	Bolzen	Perno	
	6	8A00 86138	1	Vite (M12x106 mm)	Screw (M12x106 mm)	Vis (M12x106 mm)	Schraube (M12x106 mm)	Tornillo (M12x106 mm)	
	7	8000 86140	2	Rosetta	Washer	Rondelle	Scheibe	Arandela	
	8	8A00 86136	2	Cuscinetto (ø22xø28x16 mm)	Bearing (ø22xø28x16 mm)	Roulement (ø22xø28x16 mm)	Lager (ø22xø28x16 mm)	Cojinete (ø22xø28x16 mm)	
<b>A</b>	8	8000 86136	2	Cuscinetto (ø22xø28x16 mm)	Bearing (ø22xø28x16 mm)	Roulement (ø22xø28x16 mm)	Lager (ø22xø28x16 mm)	Cojinete (ø22xø28x16 mm)	
	9	8000 38521	2	Anello di tenuta (ø22xø28x4 mm)	Seal ring (ø22xø28x4 mm)	Bague de retenue (ø22xø28x4 mm)	Dichtring (ø22xø28x4 mm)	Anillo de retención (ø22xø28x4 mm)	
	11	8000 93124	1	Vite (M12x103 mm)	Screw (M12x103 mm)	Vis (M12x103 mm)	Schraube (M12x103 mm)	Tornillo (M12x103 mm)	
	12	8000 42023	2	Dado	Nut	Ecrou	Mutter	Tuerca	
	13	8A00 93124	1	Vite (M12x121 mm)	Screw (M12x121 mm)	Vis (M12x121 mm)	Schraube (M12x121 mm)	Tornillo (M12x121 mm)	
	14	8000 72168	1	Cuscinetto sferico (ø12xø26x16 mm)	Bearing (ø12xø26x16 mm)	Roulement (ø12xø26x16 mm)	Lager (ø12xø26x16 mm)	Cojinete (ø12xø26x16 mm)	
	15	8000 38767	2	Anello	Ring	Bague	Ring	Anillo	
	16	1511 33302	2	Bussola	Bushing	Douille	Buchse	Manguito	
	17	8D00 62797	1	Vite (M10x47 mm)	Screw (M10x47 mm)	Vis (M10x47 mm)	Schraube (M10x47 mm)	Tornillo (M10x47 mm)	
	18	8000 42023	1	Dado	Nut	Ecrou	Mutter	Tuerca	
	19	8000 01412	2	Ingrassatore	Lubricator	Graisser	Schmierbüchse	Lubricador	
	20	8000 86176	1	Spinotto	Gudgeon	Axe	Bolzen	Perno	
	21	8000 86136	4	Cuscinetto (ø22xø28x20 mm)	Bearing (ø22xø28x20 mm)	Roulement (ø22xø28x20 mm)	Lager (ø22xø28x20 mm)	Cojinete (ø22xø28x20 mm)	
	22	8000 86137	4	Anello di tenuta (ø26xø34x4 mm)	Seal ring (ø26xø34x4 mm)	Bague de retenue (ø26xø34x4 mm)	Dichtring (ø26xø34x4 mm)	Anillo de retención (ø26xø34x4 mm)	
	23	8000 90561	2	Anello elastico	Split ring	Anneau ressort	Sprengring	Anillo elástico	
	24	8000 86177	2	Distanziale	Spacer	Entretoise	Distanzstück	Separadòr	
	25	8000 86177	2	Distanziale	Spacer	Entretoise	Distanzstück	Separadòr	
	26	8000 42022	1	Dado	Nut	Ecrou	Mutter	Tuerca	

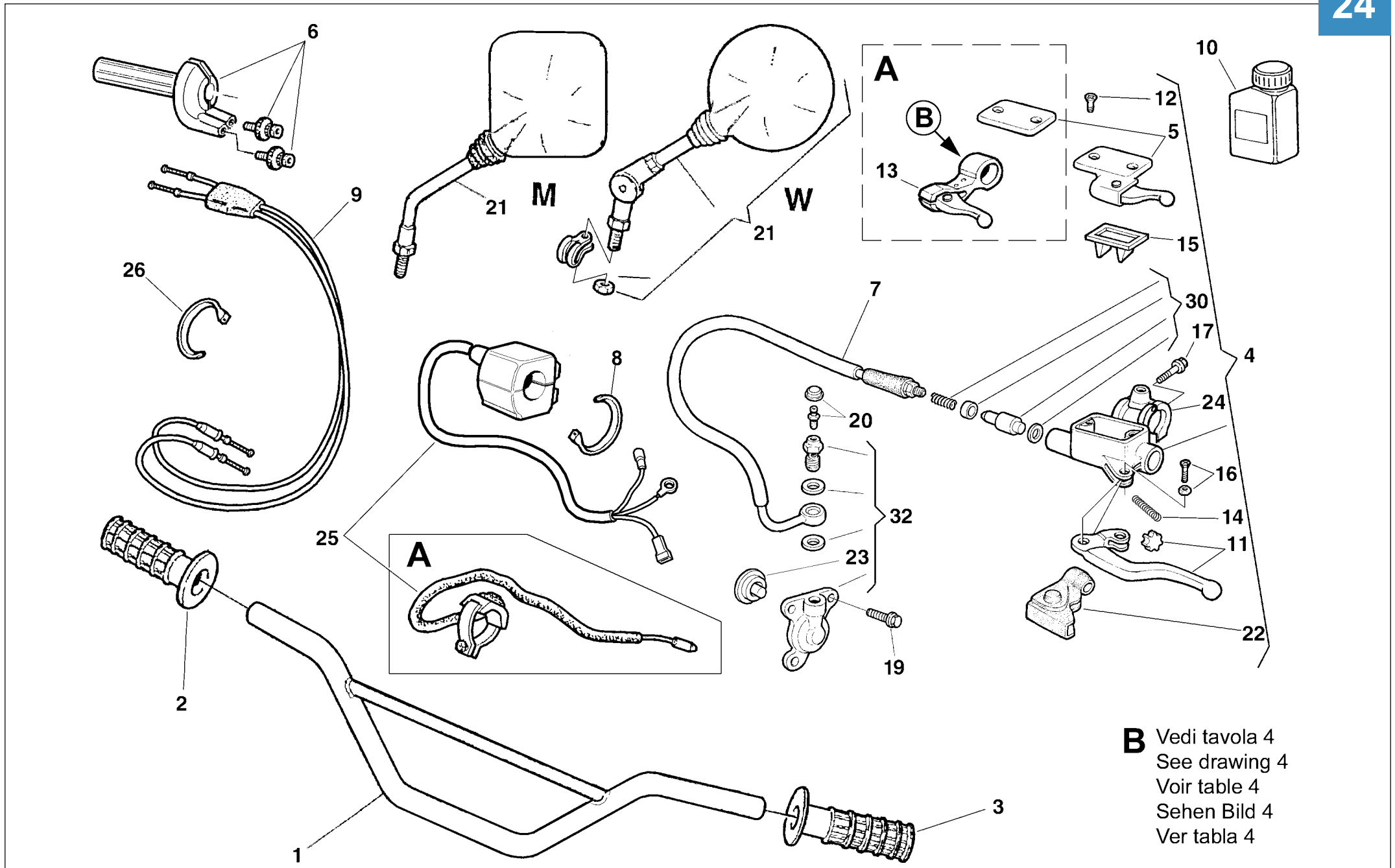

**B** Vedi tavola 4  
See drawing 4  
Voir table 4  
Sehen Bild 4  
Ver tabla 4



TC-TE 250- 450,  
SM 400R-450R/ 2004

TAVOLA  
DRAWING  
TABLE  
BILD  
TABLA

24

MANUBRIO E COMANDI - HANDLEBAR AND CONTROLS  
GUIDON ET COMMANDES - LENKER UND STEUERORGANE  
MANILLARY MANDOS

Note Notes Notas	Pos. No. Index Pos.	N. Cod. Code No. Nr. Code Code Nr N. Cod.	Q.tà Q.ty Q.te M.ge C.ad	DENOMINAZIONE	NAME	DESIGNATION	BESHREIBUNG	DENOMINACION	Validità Validity Validité Gültig Validez
	1	8000 88280	1	Manubrio	Hanblebar	Guidon	Lenker	Manillar	
	2	8000 76688	1	Manopola Dx.	R.H. grip	Poignée G.	Griff R.	Manopla der.	
	3	8000 76687	1	Manopola Sx.	L.H. grip	Poignée G.	L. Griff	Manopla izrda.	
<b>WM</b>	4	8A00 A2836	1	Ass. pompa comando frizione	Clutch control pump assy	Pompe comm. embrayage	Kupplungspumpe, Kpl.	Bomba mando embrague	
<b>C</b>	4	8000 A2836	1	Ass. pompa comando frizione	Clutch control pump assy	Pompe comm. embrayage	Kupplungspumpe, Kpl.	Bomba mando embrague	
<b>AY</b>	4	8A00 99666	1	Ass. pompa comando frizione	Clutch control pump assy	Pompe comm. embrayage	Kupplungspumpe, Kpl.	Bomba mando embrague	
	5	8000 A2840	1	Coperchietto con leva com. alzavalvole	Cover with valve lifter control lever	Couvercle avec levier comm. dispositif de décompression	Deckel mit Decompressionvor- richtungshebel	Tapa con palanca mando dispositivo decompression	
<b>F</b>	5	8000 A0912	1	Coperchietto	Cover	Couvercle	Deckel	Tapa	
	6	8000 98209	1	Comando gas completo	Throttle control compl.	Commande gaz compl.	Gasgriff kpl.	Accionam. acelerador compl.	
	7	8000 A2841	1	Tubo mandata olio	Hose	Tuyau	Rohr	Tubo	
<b>F</b>	7	8000 99615	1	Tubo mandata olio	Hose	Tuyau	Rohr	Tubo	
	8	8000 50005	1	Fascetta	Clamp	Collier	Schelle	Banda	
	9	8000 96833	1	Trasmissione comando gas	Throttle wire	Fil comm. gaz	Gaszugkabel	Trans. accionam. acelerador	
	10	8000 A0878	1	Olio frizione	Clutch oil	Huile embrayage	Kupplungsol	Aceite embrague	
	11	8000 A2837	1	Leva frizione	Clutch lever	Levier embrayage	Kupplungshebel	Palanca mando embrague	
<b>F</b>	11	8000 A0911	1	Leva frizione	Clutch lever	Levier embrayage	Kupplungshebel	Palanca mando embrague	
	12	8000 A0055	2	Vite	Screw	Vis	Schraube	Tornillo	
<b>F</b>	13	8000 96835	1	Ass. leva comando alzavalvole	Valve lifter control lever assy	Levier comm. disp. décompr.	Decompr. Vorrichtungshebel	Gr. palanca mando decompr.	
	14	8000 A3408	1	Molla	Spring	Ressort	Feder	Resorte	
	15	8000 A0913	1	Diaframma	Diaphram	Diaphragme	Biegeplatte	Diafragma	
	16	8000 A0877	1	Gruppo vite fiss. leva	Adjuster set	Groupe reglage	Kupplungsreglergruppe	Grupo regul.	
	17	8000 62728	1	Vite	Screw	Vis	Schraube	Tornillo	
<b>Y</b>	18	8A00 A0939	1	Cavallotto	U-bolt	Cavalier	Bügelbolzen	Caballate	
<b>C</b>	18	8000 A0939	1	Cavallotto	U-bolt	Cavalier	Bügelbolzen	Caballate	
	19	8000 62727	3	Vite	Screw	Vis	Schraube	Tornillo	
	20	8000 A3410	1	Valvola di spurgo	Bleeding valve	Soupape de curage	Zangenentleerungsventil	Válvula de purga	
<b>XWD</b>	21	8000 65437	2	Specchietto retrov. Dx. e Sx.	Driving mirror	Rétroviseur	Rückspiegel	Espejo retrovisor	
<b>XMD</b>	21	8B00 68934	1	Specchietto retrov. Dx.	R.H. Driving mirror	Rétroviseur D.	R. Rückspiegel	Espejo retrovisor der.	
<b>XMD</b>	21	8C00 68934	1	Specchietto retrov. Sx.	L.H. Driving mirror	Rétroviseur G.	L. Rückspiegel	Espejo retrovisor iz.	
	22	8000 A0915	1	Protezione leva	Lever guard	Protection levier	Hebelschutz	Proteccion palanca	
	23	8000 A3409	1	Gruppo pistone	Piston	Piston	Kolben	Pistón	
<b>A</b>	25	8000 99624	1	Commutatore DX compl.	R.H. Switch compl.	Commutateur D. compl.	R. Kombischalter kpl.	Conmutador D. compl.	

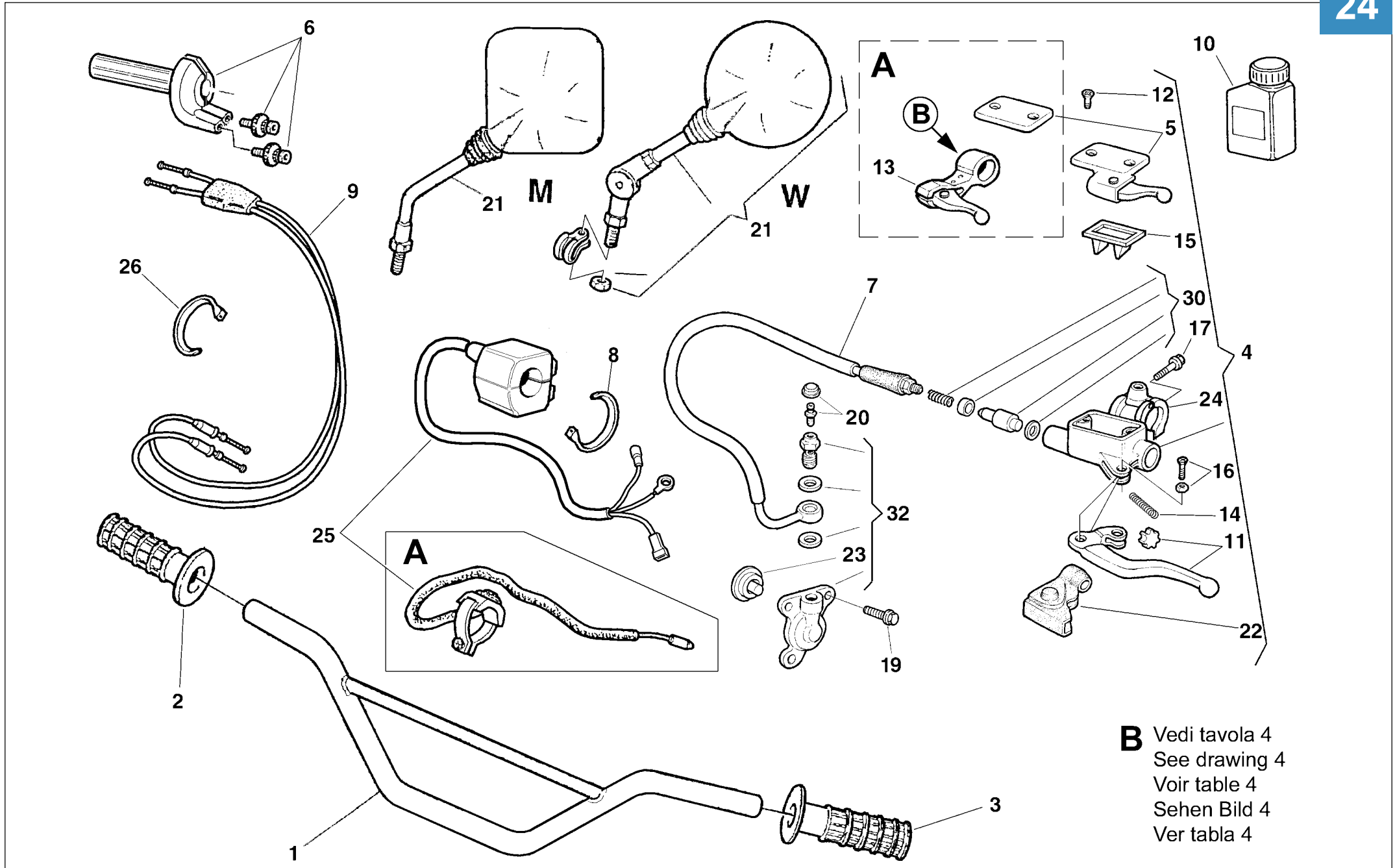

**B** Vedi tavola 4  
See drawing 4  
Voir table 4  
Sehen Bild 4  
Ver tabla 4



Note Notes Marke Notas	Pos. No. N. Index Pos.	N. Cod. Code No. Nr. Code Code Nr N. Cod.	Q.tà Q.ty Q.té M.ge C.ad	DENOMINAZIONE	NAME	DESIGNATION	BESHREIBUNG	DENOMINACION	Validità Validity Validité Gültig Validez
	25	8000 A2843	1	Commutatore DX compl.	R.H. Switch compl.	Commutateur D. compl.	R. Kombischalter kpl.	Conmutador D. compl.	
	26	8000 71578	4	Fascetta	Clamp	Collier	Schelle	Banda	
	30	8000 A0914	1	Gruppo pistone	Piston	Piston	Kolben	Pistón	
	32	8000 99928	1	Cilindro com. frizione	Clutch control cylinder	Cylindre comm. embrayage	Kupplungszyylinder	Cilindro mando embrague	
<b>F</b>				Fornire in abbinamento al part. 8A00 99666 pos. 4	Supply unitedly to part 8A00 99666 no. 4	Fournir ensemble à part. 8A00 99666 N. 4	Wird Paaren mit Teile 8A00 99666 ind. 4	Equipar acoplado al part. 8A00 99666 pos. 4	

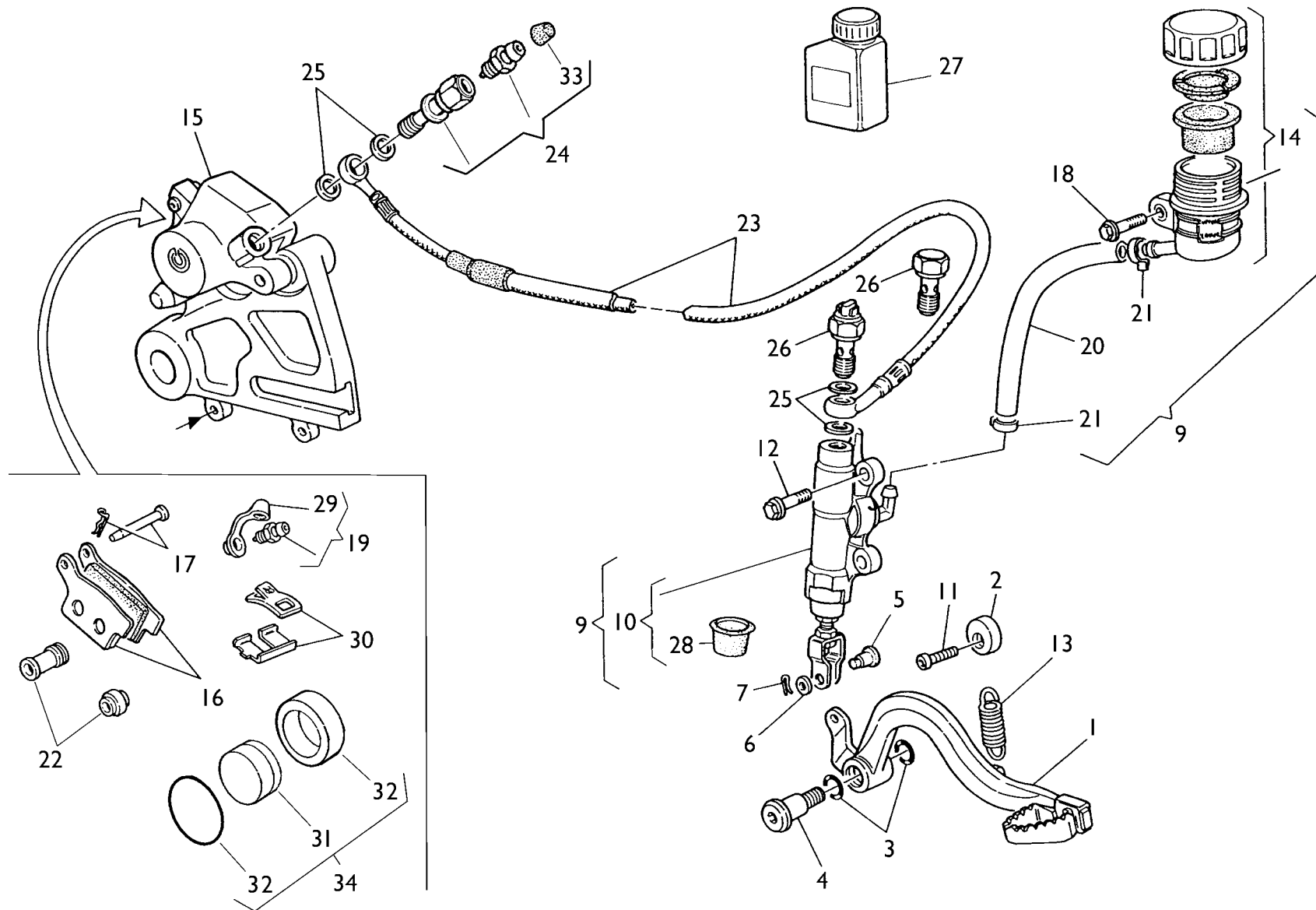



**TC-TE 250- 450,  
SM 400R-450R/ 2004**

TAVOLA  
DRAWING  
TABLE  
BILD  
TABLA

**25**

**FRENO IDRAULICO POSTERIORE - REAR HYDRAULIC BRAKE  
FREIN HYDRAULIQUE ARRIERE - HINTERBREMSE  
FRENO HIDRAULICO TRASERO**

Note Notes Notes Markes	Pos. No. N. Index Pos.	N. Cod. Code No. Nr. Code Code Nr N. Cod.	Q.tà Q.ty Q.ty M.ge C.ad	DENOMINAZIONE	NAME	DESIGNATION	BESHREIBUNG	DENOMINACION	Validità Validity Validité Gültig Validez
	1	8000 73894	1	Pedale comando freno	Brake control pedal	Pedal comm. frein	Bremspedal	Pedal accionamiento freno	
	2	8000 69125	1	Camma	Cam	Came	Nocken	Exéntrico	
	3	8000 22551	2	Anello OR	O-Ring	Bague OR	O-Ring	Anillo OR	
	4	8000 55902	1	Vite	Screw	Vis	Schraube	Tornillo	
	5	8000 70696	1	Perno	Pin	Pivot	Bolzen	Perno	
	6	8000 56377	1	Rosetta	Washer	Rondelle	Scheibe	Arandela	
	7	64N1 20068	1	Copiglia	Split pin	Goupille	Splint	Clavija	
	9	8A00 76026	1	Pompa comando freno compl.	Brake pump assy	Pompe frein complet	Bremspumpe kl.	Bomba freno compl.	
	10	8000 76338	1	Pompa freno	Brake pump	Pompe frein	Bremspumpe	Bomba freno	
	11	8A00 55241	1	Vite	Screw	Vis	Schraube	Tornillo	
	12	8000 62727	2	Vite	Screw	Vis	Schraube	Tornillo	
	13	8000 55903	1	Molla	Spring	Ressort	Feder	Resorte	
	14	8000 61078	1	Serbatoio olio completo	Oil tank assy	Reservoir huile compl.	Öltank Kpl.	Depósito aceite completo	
<b>Y</b>	15	8000 96939	1	Pinza freno completa	Brake caliper assy	Pince de frein, compl.	Bremszange, Kpl.	Pinza freno compl.	
<b>C</b>	15	8000 A2787	1	Pinza freno completa	Brake caliper assy	Pince de frein, compl.	Bremszange, Kpl.	Pinza freno compl.	
<b>Y</b>	16	8000 79072	1	Coppia pastiglie	Pads pair	Paire plaquettes	Bremsbelagpaar	Pareja pastillas	
<b>C</b>	16	8000 A2790	1	Coppia pastiglie	Pads pair	Paire plaquettes	Bremsbelagpaar	Pareja pastillas	
<b>Y</b>	17	8000 A0933	1	Perno	Pin	Pivot	Bolzen	Perno	
<b>C</b>	17	8000 A2791	1	Perno	Pin	Pivot	Bolzen	Perno	
	18	8000 62725	1	Vite	Screw	Vis	Schraube	Tornillo	
<b>Y</b>	19	8000 A0931	1	Spurgo	Spurgo	Drain	Entleerung	Purga	
	20	8L00 66179	1	Tubazione	Pipe	Tuyau	Rohr	Tubo	
	21	8000 42349	2	Molletta	Spring	Ressort	Feder	Resorte	
	22	8000 79066	1	Cuffie	Boots	Poussiers	haube	Gorro	
<b>Y</b>	23	8000 A0665	1	Tubo mandata olio	Pipe	Tuyau	Rohr	Tubo	
<b>C</b>	23	8A00 A0665	1	Tubo mandata olio	Pipe	Tuyau	Rohr	Tubo	
<b>Y</b>	24	8000 57155	1	Vite	Screw	Vis	Schraube	Tornillo	
<b>C</b>	24	8000 A3975	1	Vite	Screw	Vis	Schraube	Tornillo	
	25	8000 21480	4	Rosetta	Washer	Rondelle	Scheibe	Arandela	
<b>WM</b>	26	8000 94849	1	Interruttore stop posteriore	Rear stop switch	Interrupteur stop	Stopschalter	Interruptor stop	
<b>UC</b>	26	8000 57155	1	Vite	Screw	Vis	Schraube	Tornillo	
<b>R</b>	27	8000 71445	1	Olio freni	Brake oil	Huile de frein	BremsÖl	Aceite freno	
	28	8000 79075	1	Cuffia	Boot	Poussier	haube	Gorro	

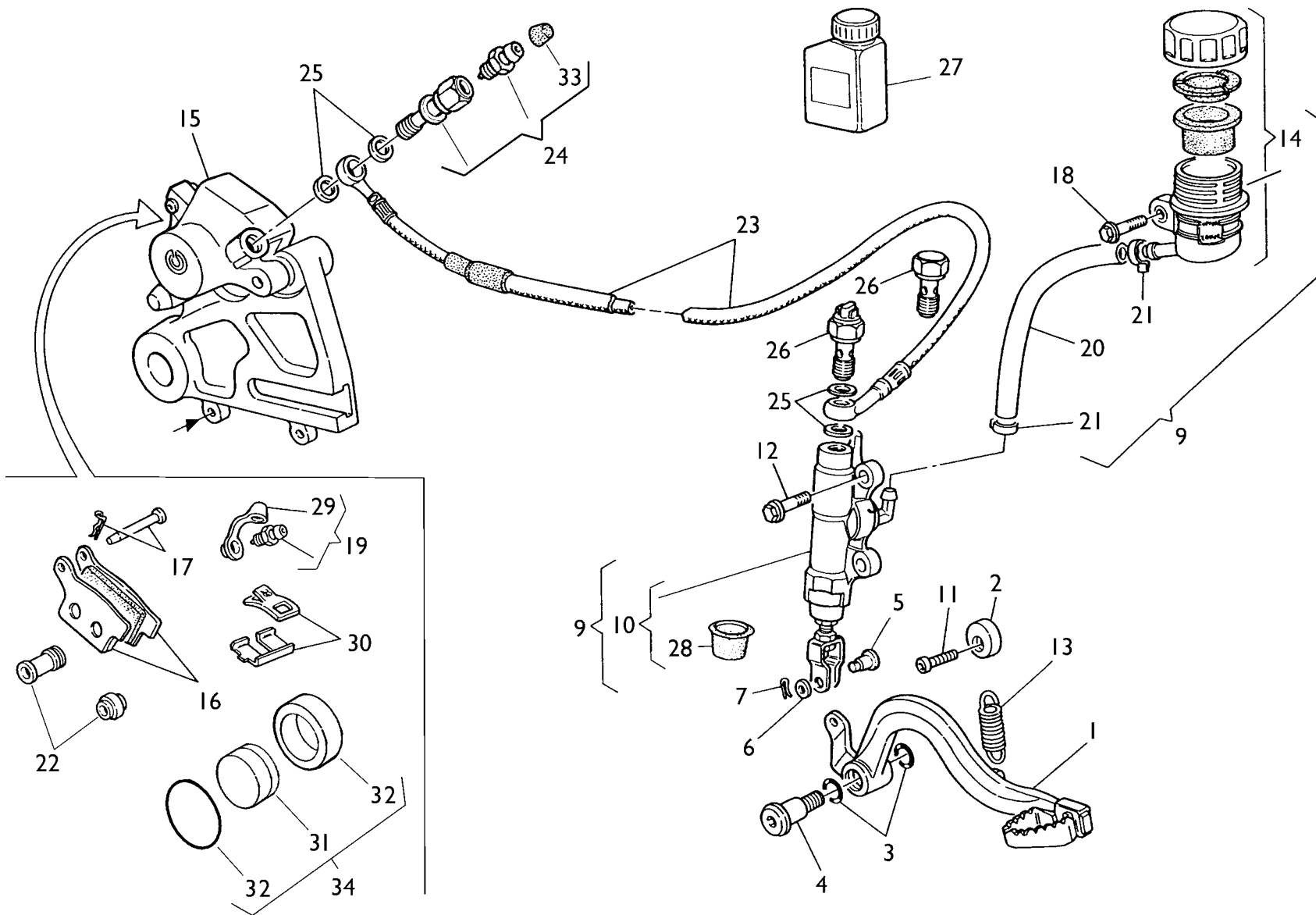



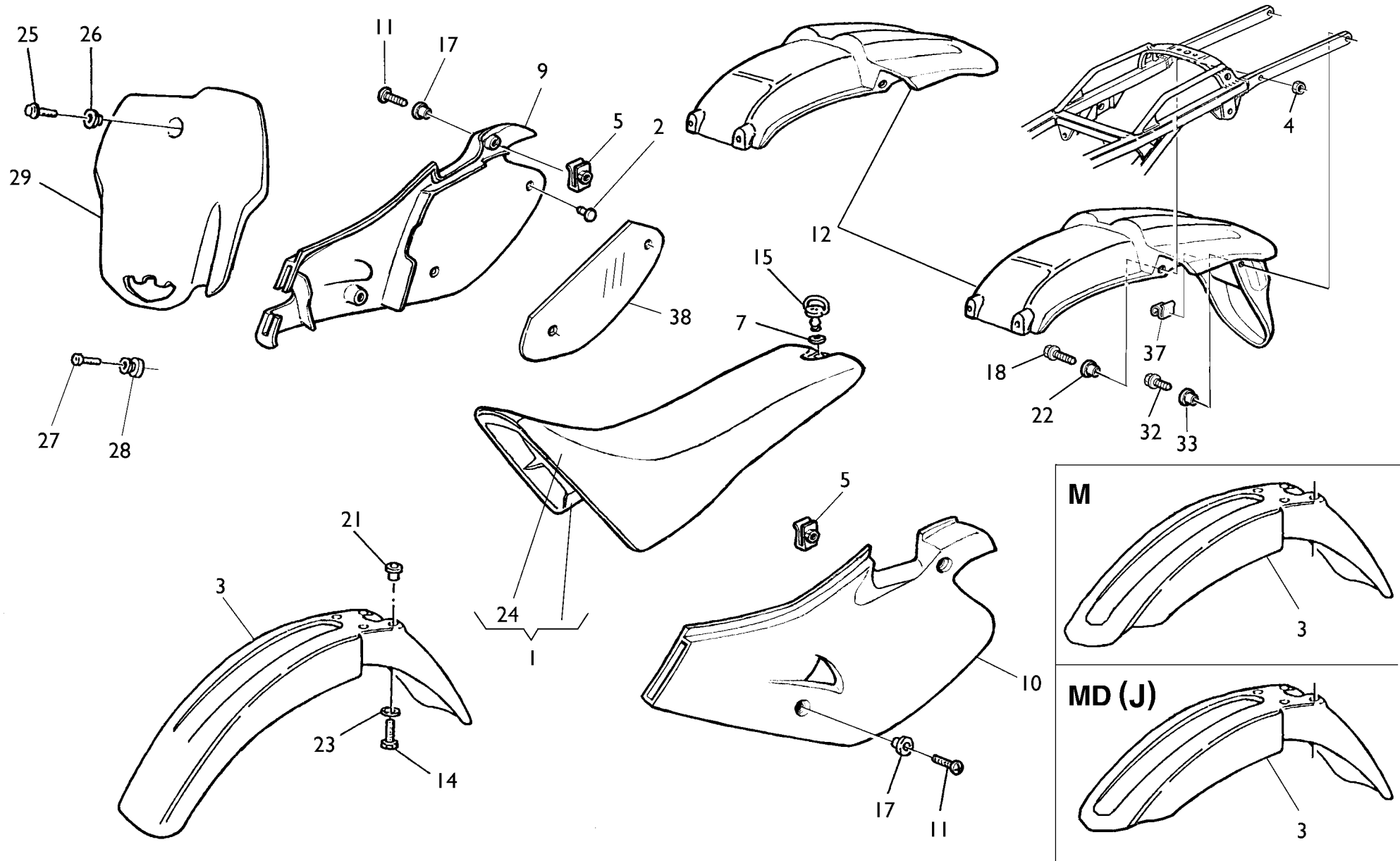





**TC-TE 250- 450,  
SM 400R-450R/ 2004**

TAVOLA  
DRAWING  
TABLE  
BILD  
TABLA

**26**

**PANNELLI, PARAFANGHI, SELLA - PANEL, FENDERS, SEAT  
PANNEAU, GARDE-BOUES, SIEGE - STREIFEN, KOTFLUGEL, SATTEL  
PANELO, GUARDABARROS, SILLIN**

Note Notes Notes Marke Notas	Pos. No. N. Index Pos.	N. Cod. Code No. Nr. Code Code Nr N. Cod.	Q.tà Q.ty Q.te M.ge C.ad	DENOMINAZIONE	NAME	DESIGNATION	BESHREIBUNG	DENOMINACION	Validità Validity Validité Gültig Validez
<b>WC</b>	1	8000 A0050	1	Sella	Seat	Siège	Sattel	Sillín	
<b>M</b>	1	8B00 A0050	1	Sella (codice colore E)	Seat (color code E)	Siège (code couleur E)	Sattel (Code Farbe E)	Sillín (còdigo colòr E)	
<b>MØ</b>	1	8A00 A0050	1	Sella (codice colore G)	Seat (color code G)	Siège (code couleur G)	Sattel (Code Farbe G)	Sillín (còdigo colòr G)	
<b>WC</b>	2	8000 48802	2	Gommino anticalore	Rubber pad	Pièce caoutchouc	Gummistück	Junta de goma	
<b>M</b>	3	8000 A1589	1	Parafango ant.	Front mudguard	Garde-boue avant	Vord. Kotfluegel	Guarda-barros del.	
	3	8000 A1761	1	Parafango ant. (tipo corto) (codice colore E)	Front mudguard (short type) (color code E)	Garde-boue avant (type court) (code couleur E)	Vord. Kotfluegel (short type) (Code Farbe E)	Guarda-barros del. (tipo corto) (còdigo colòr E)	
<b>MØ</b>	3	80A0 A1761	1	Parafango ant. (tipo corto) (codice colore G)	Front mudguard (short type) (color code G)	Garde-boue avant (type court) (code couleur G)	Vord. Kotfluegel (short type) (Code Farbe G)	Guarda-barros del. (tipo corto) (còdigo colòr G)	
<b>DM¥</b>	3	8A00 98534	1	Parafango ant. (tipo corto)	Front mudguard (short type)	Garde-boue avant (type court)	Vord. Kotfluegel (short type)	Guarda-barros del. (tipo corto)	
	4	8000 61313	2	Dado	Nut	Ecrou	Mutter	Tuerca	
	5	8000 46893	2	Dado	Nut	Ecrou	Mutter	Tuerca	
	7	8000 69149	1	Rosetta elastica	Spring washer	Rondelle élastique	Federscheibe	Arandela elástica	
<b>WC</b>	9	8AB0 88866	1	Pannello destro	R.H. panel	Panneau, D.	Streifen. R.	Panel Der.	
<b>M</b>	9	8AB0 88866	1	Pannello destro (codice colore E)	R.H. panel (color code E)	Panneau, D. (code couleur E)	Streifen. R. (Code Farbe E)	Panel Der. (còdigo colòr E)	
<b>MØ</b>	9	8AA0 88866	1	Pannello destro (codice colore G)	R.H. panel (color code G)	Panneau, D. (code couleur G)	Streifen. R. (Code Farbe G)	Panel Der. (còdigo colòr G)	
<b>WC</b>	10	8AB0 88867	1	Pannello sinistro	L.H. panel	Panneau, G.	Streifen. L.	Panel Izq.	
<b>M</b>	10	8AB0 88867	1	Pannello sinistro (codice colore E)	L.H. panel (color code E)	Panneau, G. (code couleur E)	Streifen. L. (Code Farbe E)	Panel Izq. (còdigo colòr E)	
<b>MØ</b>	10	8AA0 88867	1	Pannello sinistro (codice colore G)	L.H. panel (color code G)	Panneau, G. (code couleur G)	Streifen. L. (Code Farbe G)	Panel Izq. (còdigo colòr G)	
	11	8000 62728	4	Vite	Screw	Vis	Schraube	Tornillo	
<b>W</b>	12	8000 A0545	1	Parafango post.	Rear mudguard	Garde-boue arriere	Hint. Kotfluegel	Guarda-barros tras.	
<b>QUC</b>	12	8000 A0546	1	Parafango post. (codice colore E)	Rear mudguard (color code E)	Garde-boue arriere (code couleur E)	Hint. Kotfluegel (Code Farbe E)	Guarda-barros tras. (còdigo colòr E)	
<b>Q</b>	12	8CA0 A0546	1	Parafango post. (codice colore G)	Rear mudguard (color code G)	Garde-boue arriere (code couleur G)	Hint. Kotfluegel (Code Farbe G)	Guarda-barros tras. (còdigo colòr G)	
<b>M</b>	12	8000 A0545	1	Parafango post. (codice colore E)	Rear mudguard (color code E)	Garde-boue arriere (code couleur E)	Hint. Kotfluegel (Code Farbe E)	Guarda-barros tras. (còdigo colòr E)	

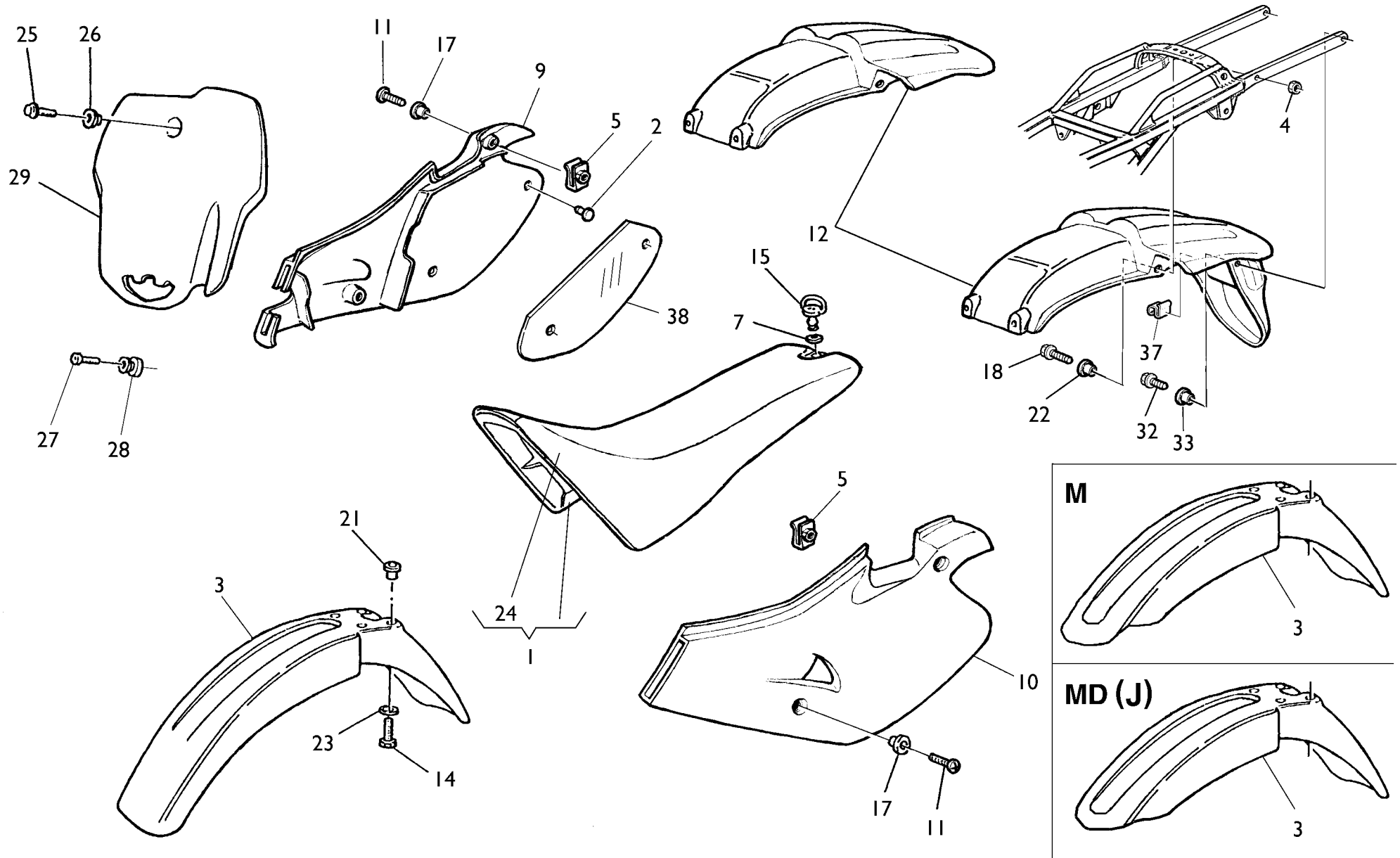



**TC-TE 250- 450,  
SM 400R-450R/ 2004**

TAVOLA  
DRAWING  
TABLE  
BILD  
TABLA

**26**

**PANNELLI, PARAFANGHI, SELLA - PANEL, FENDERS, SEAT  
PANNEAU, GARDE-BOUES, SIEGE - STREIFEN, KOTFLUGEL, SATTEL  
PANELO, GUARDABARROS, SILLIN**

Note Notes Mark Notas	Pos. No. N. Index Pos.	N. Cod. Code No. Nr. Code Code Nr N. Cod.	Q.tà Q.ty Q.te M.ge C.ad	DENOMINAZIONE	NAME	DESIGNATION	BESHREIBUNG	DENOMINACION	Validità Validity Validité Gültig Validez
<b>MØ</b>	12	8CA0 A0545	1	Parafango post. (codice colore G)	Rear mudguard (color code G)	Garde-boue arriere (code couleur G)	Hint. Kotfluegel (Code Farbe G)	Guarda-barros tras. (còdigo colòr G)	
	14	8000 62727	4	Vite	Screw	Vis	Schraube	Tornillo	
	15	8000 69148	1	Perno	Pin	Pivot	Bolzen	Perno	
	17	8000 69429	4	Boccola	Bushing	Douille	Buchse	Casquillo	
	18	8000 62728	2	Vite (M6x20mm)	Screw (M6x20mm)	Vis (M6x20mm)	Schraube (M6x20mm)	Tornillo (M6x20mm)	
	21	8000 69429	4	Bussola	Bushing	Douille	Buchse	Manguito	
	22	8000 69429	2	Bussola	Bushing	Douille	Buchse	Manguito	
	23	8000 48814	4	Rosetta	Washer	Rondelle	Scheibe	Arandela	
<b>WC</b>	24	8000 A0051	1	Rivestimento sella	Saddle covering	Revetement selle	Sattelverkleidung	Revestimiento sillin	
<b>M</b>	24	8000 A0051	1	Rivestimento sella (codice colore E)	Saddle covering (color code E)	Revetement selle (code couleur E)	Sattelverkleidung (Code Farbe E)	Revestimiento sillin (còdigo colòr E)	
<b>M</b>	24	8A00 A0051	1	Rivestimento sella (codice colore G)	Saddle covering (color code G)	Revetement selle (code couleur G)	Sattelverkleidung (Code Farbe G)	Revestimiento sillin (còdigo colòr G)	
<b>UC</b>	25	8C00 67997	1	Vite	Screw	Vis	Schraube	Tornillo	
<b>UC</b>	26	8B00 69282	1	Bussola	Bushing	Douille	Buchse	Manguito	
<b>UC</b>	27	8000 62726	2	Vite	Screw	Vis	Schraube	Tornillo	
<b>UC</b>	28	8000 A0241	2	Attacco portanumero	Spacer	Entretoise	Distanzstück	Separadòr	
<b>QUC</b>	29	80B0 87800	1	Portanumero (codice colore E)	Front number holder (color code E)	Portanumero (code couleur E)	Nummerträger (Code Farbe E)	Portanumero (còdigo colòr E)	
<b>Q</b>	29	80A0 87800	1	Portanumero (codice colore G)	Front number holder (color code G)	Portanumero (code couleur G)	Nummerträger (Code Farbe G)	Portanumero (còdigo colòr G)	
<b>WM</b>	32	8000 62726	2	Vite (M6x14mm)	Screw (M6x14mm)	Vis (M6x14mm)	Schraube (M6x14mm)	Tornillo (M6x14mm)	
<b>WM</b>	33	8000 45495	2	Bussola	Bushing	Douille	Buchse	Manguito	
<b>Y</b>	37	8000 72494	1	Molletta fiss. cavo ind. post. dx	Spring	Ressort	Feder	Muelle	
	38	8000 95727	1	Protezione	Guard	Protection	Schutz	Protección	

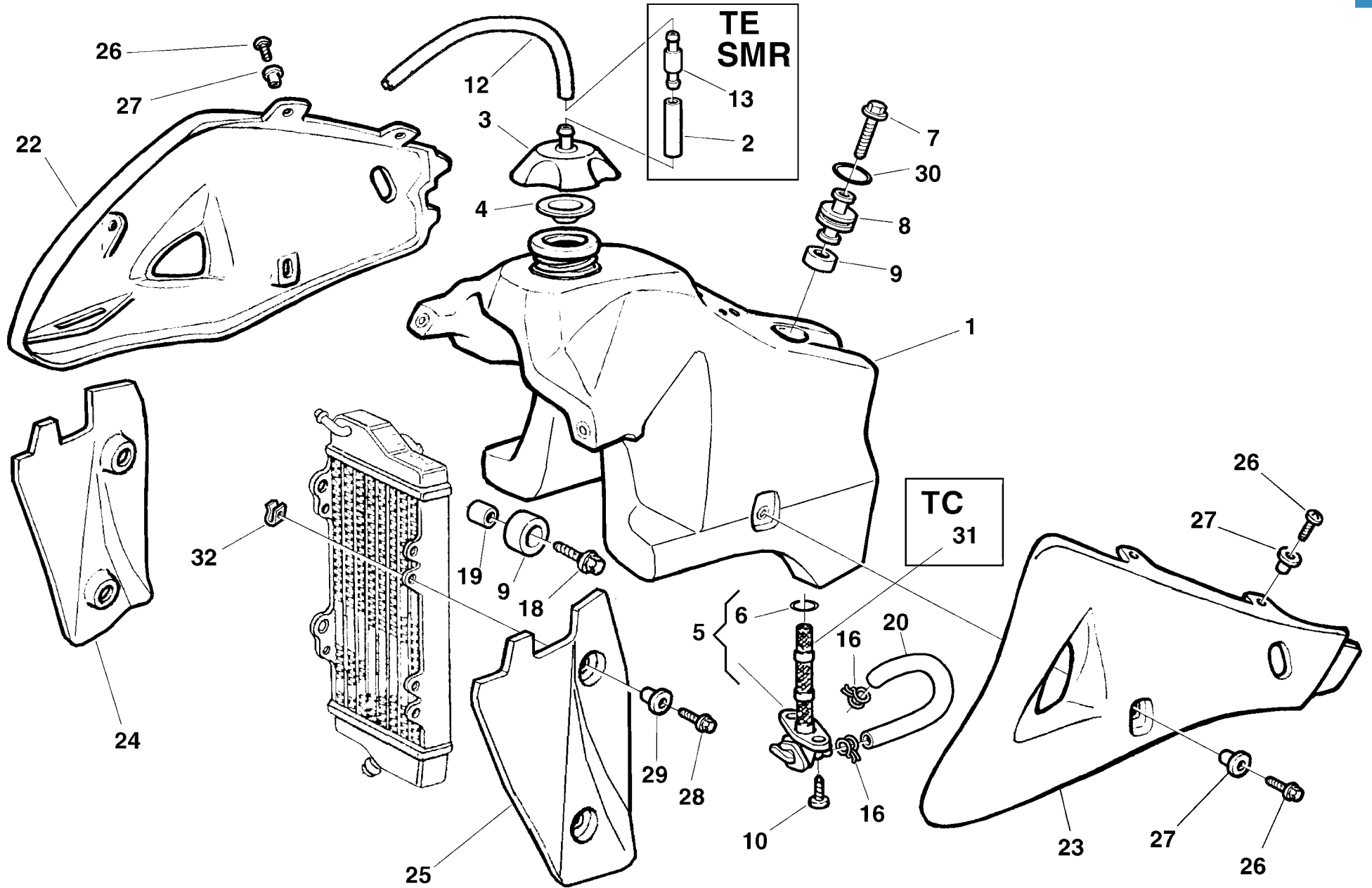



**TC-TE 250- 450,  
SM 400R-450R/ 2004**

TAVOLA  
DRAWING  
TABLE  
BILD  
TABLA

**27**

**SERBATOIO CARBURANTE, CONVOGLIATORI - GAS TANK, PANEL -  
RESERVOIR CARBURANT, FLANC - KRAFTSTOFFBEHALTER, FLANKE -  
DEPOSITO GASOLINA, LATERAL**

Note Notes Notas Markes	Pos. No. N. Index Pos.	N. Cod. Code No. Nr. Code Code Nr N. Cod.	Q.tà Q.ty Q.te M.ge C.ad	DENOMINAZIONE	NAME	DESIGNATION	BESHREIBUNG	DENOMINACION	Validità Validity Validité Gültig Validez
	1	8000 99631	1	Serbatoio carburante (l 7)	Fuel tank (l 7)	Réservoir essence (l 7)	Kraftstoffbehälter (l 7)	Depósito gasolina (l 7)	
<b>WM</b>	2	8W00 68873	1	Condotta benzina (L=40 mm)	Pipe (L=40 mm)	Tuyau (L=40 mm)	Rohr (L=40 mm)	Tubo (L=40 mm)	
	3	8000 94098	1	Tappo	Plug	Bouchon	Verschluss	Tapón	
	4	8000 56381	1	Guarnizione	Gasket	Garniture	Dichtung	Junta	
<b>WM</b>	5	8000 A0339	1	Rubinetto benzina	R.H. cock	Robinet D.	R.Kraftstoffhahn	Llave de paso der.	
<b>C</b>	5	8000 43592	1	Rubinetto benzina	R.H. cock	Robinet D.	R.Kraftstoffhahn	Llave de paso der.	
	6	8000 01199	1	Anello OR	O-Ring	Bague OR	O-Ring	Anillo OR	
<b>E</b>	7	8D00 67545	1	Vite (M6x60 mm)	Screw (M6x60 mm)	Vis (M6x60 mm)	Schraube (M6x60 mm)	Tornillo (M6x60 mm)	
	7	8B00 67545	1	Vite (M6x55 mm)	Screw (M6x55 mm)	Vis (M6x55 mm)	Schraube (M6x55 mm)	Tornillo (M6x55 mm)	
<b>E</b>	8	8000 A0702	1	Distanziale (48,7mm)	Spacer (48,7mm)	Entretoise (48,7mm)	Distanzstück (48,7mm)	Separador (48,7mm)	
	8	8A00 A0702	1	Distanziale (42,7mm)	Spacer (42,7mm)	Entretoise (42,7mm)	Distanzstück (42,7mm)	Separador (42,7mm)	
	9	8000 A0528	3	Tampone	Pad	Tampon	Stopfen	Tampón	
	10	8000 37745	2	Vite	Screw	Vis	Schraube	Tornillo	
	12	8S00 68873	1	Condotta benzina (L=380 mm)	Pipe (L=380 mm)	Tuyau (L=380 mm)	Rohr (L=380 mm)	Tubo (L=380 mm)	
<b>WM</b>	13	8000 99595	1	Valvola di non ritorno	Valve	Soupape	Ventil	Válvula	
	16	80A0 42349	2	Fascetta	Clamp	Collier	Schelle	Banda	
	18	60N1 02510	2	Vite	Screw	Vis	Schraube	Tornillo	
	19	8000 A0680	2	Distanziale	Spacer	Entretoise	Distanzstück	Separador	
	20	8B00 94010	1	Condotta benzina (L=240 mm)	Pipe (L=240 mm)	Tuyau (L=240 mm)	Rohr (L=240 mm)	Tubo (L=240 mm)	
<b>WC</b>	22	8AB0 88869	1	Convogliatore DX	R. side panel	Flanc D.	Flanke R.	Lateral D.	
<b>M</b>	22	8AB0 88869	1	Convogliatore DX (codice colore E)	R. side panel (color code E)	Flanc D. (code couleur E)	Flanke R. (Code Farbe E)	Lateral D. (còdigo colòr E)	
<b>M</b>	22	8AA0 88869	1	Convogliatore DX (codice colore G)	R. side panel (color code G)	Flanc D. (code couleur G)	Flanke R. (Code Farbe G)	Lateral D. (còdigo colòr G)	
<b>WC</b>	23	8AB0 88868	1	Convogliatore SX	L. side panel	Flanc G.	Flanke L.	Lateral I.	
<b>M</b>	23	8AB0 88868	1	Convogliatore SX (codice colore E)	L. side panel (color code E)	Flanc G. (code couleur E)	Flanke L. (Code Farbe E)	Lateral I. (còdigo colòr E)	
<b>M</b>	23	8AA0 88868	1	Convogliatore SX (codice colore G)	L. side panel (color code G)	Flanc G. (code couleur G)	Flanke L. (Code Farbe G)	Lateral I. (còdigo colòr G)	
	24	8000 A0668	1	Protezione Dx	R.H. protection	Protection D.	Schutz Rechte	Protección derecha	
	25	8000 A0667	1	Protezione Sx	L.H. protection	Protection G.	Schutz Linke	Protección izquierda	
	26	8000 36467	8	Vite (M6x10 mm)	Screw (M6x10 mm)	Vis (M6x10 mm)	Schraube (M6x10 mm)	Tornillo (M6x10 mm)	
	27	8000 45495	8	Bussola	Bushing	Douille	Buchse	Manguito	

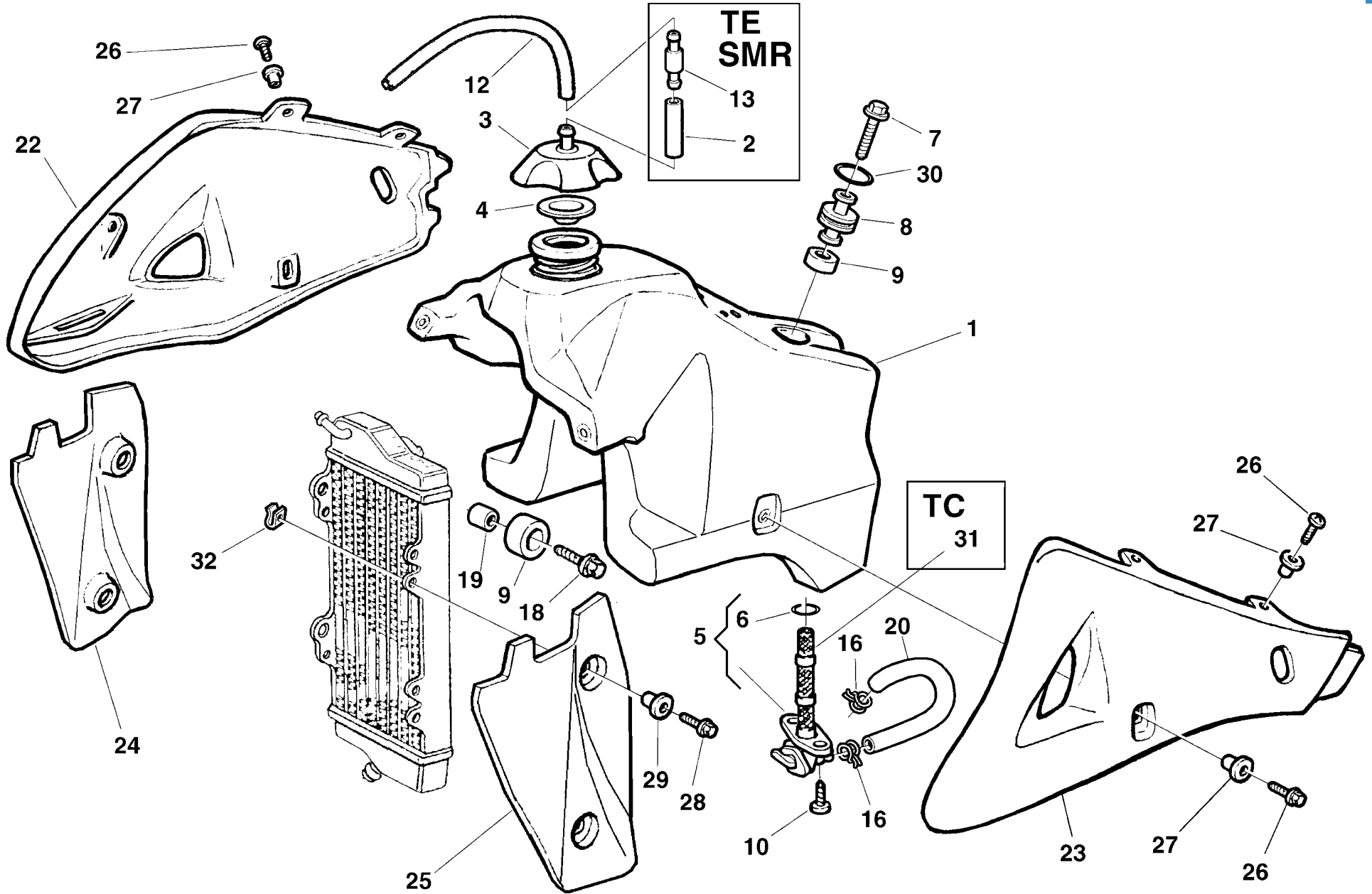





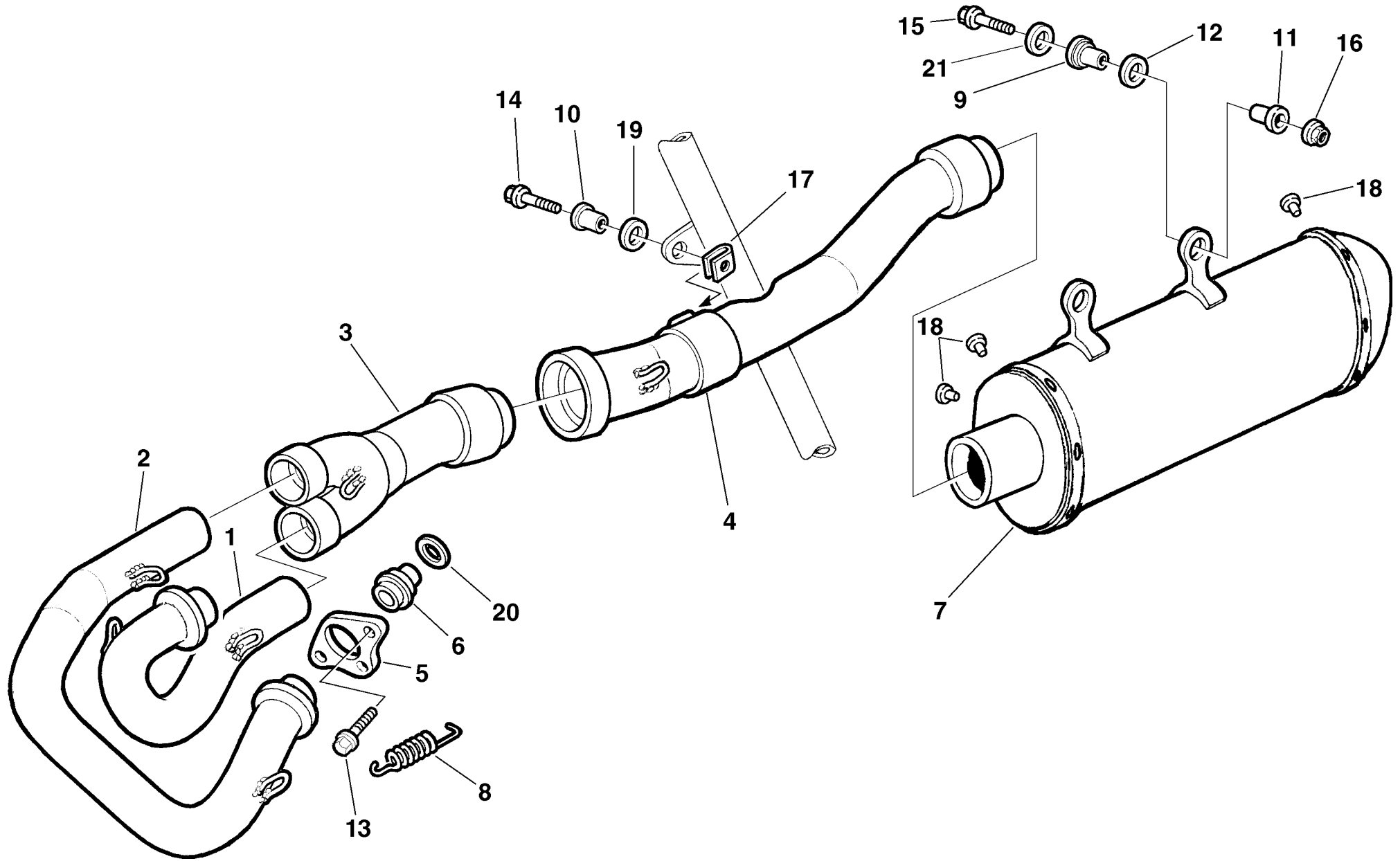



**TC-TE 250- 450,  
SM 400R-450R/ 2004**

TAVOLA  
DRAWING  
TABLE  
BILD  
TABLA

**28**

**SCARICO-EXHAUST SYSTEM  
TUYAU D'ECHAPPEMENT - AUSPUFFROHR  
TUBO DE ESCAPE**

Note Notes Notas	Pos. No. Index Pos.	N. Cod. Code No. Nr. Code Code Nr N. Cod.	Q.tà Q.ty Q.te M.ge C.ad	DENOMINAZIONE	NAME	DESIGNATION	BESHREIBUNG	DENOMINACION	Validità Validity Validité Gültig Validez
<b>WM</b>	1	8000 A0866	1	Tubo di scarico Dx	R.H. exhaust pipe	Tuyau d'échapp. D.	Auspuffrohr R.	Tubo de escape der.	
<b>C</b>	1	8A00 A0866	1	Tubo di scarico Dx	R.H. exhaust pipe	Tuyau d'échapp. D.	Auspuffrohr R.	Tubo de escape der.	
<b>WM</b>	2	8000 A0867	1	Tubo di scarico Sx	L.H. exhaust pipe	Tuyau d'échapp. G.	Auspuffrohr L.	Tubo de escape izq.	
<b>C</b>	2	8A00 A0867	1	Tubo di scarico Sx	L.H. exhaust pipe	Tuyau d'échapp. G.	Auspuffrohr L.	Tubo de escape izq.	
	3	8000 A0868	1	Raccordo anteriore (TE 250)	Front union (TE 250)	Raccord avant (TE 250)	Anschluss (TE 250)	Empalme (TE 250)	
	3	8A00 A0868	1	Raccordo anteriore (TC 250)	Front union (TC 250)	Raccord avant (TC 250)	Anschluss (TC 250)	Empalme (TC 250)	
	3	8A00 A0891	1	Raccordo anteriore (TC 450)	Front union (TC 450)	Raccord avant (TC 450)	Anschluss (TC 450)	Empalme (TC 450)	
	3	8000 A0891	1	Raccordo anteriore (TE - SMR 450)(TE 450 USA)	Front union (TE - SMR 450)(TE 450 USA)	Raccord avant (TE - SMR 450)(TE 450 USA)	Anschluss (TE - SMR 450)(TE 450 USA)	Empalme (TE - SMR 450)(TE 450 USA)	
	4	8000 A0869	1	Raccordo (TE 250)	Union (TE 250)	Raccord (TE 250)	Anschluss (TE 250)	Empalme (TE 250)	
	4	8A00 A0869	1	Raccordo (TC 250)	Union (TC 250)	Raccord (TC 250)	Anschluss (TC 250)	Empalme (TC 250)	
	4	8A00 A0892	1	Raccordo (TC 450)	Union (TC 450)	Raccord (TC 450)	Anschluss (TC 450)	Empalme (TC 450)	
	4	8000 A0892	1	Raccordo (TE - SMR 450)(TE 450 USA)	Union (TE - SMR 450)(TE 450 USA)	Raccord (TE - SMR 450)(TE 450 USA)	Anschluss (TE - SMR 450)(TE 450 USA)	Empalme (TE - SMR 450)(TE 450 USA)	
	5	8000 A0870	2	Flangia	Flange	Bride	Flansch	Brida	
	6	8000 A0871	2	Bussola (TE-TC 250)	Bushing (TE-TC 250)	Douille (TE-TC 250)	Buchse (TE-TC 250)	Manguito (TE-TC 250)	
	6	8000 A0893	2	Bussola (TE-TC- SMR 450)	Bushing (TE-TC- SMR 450)	Douille (TE-TC- SMR 450)	Buchse (TE-TC- SMR 450)	Manguito (TE-TC- SMR 450)	
	7	8000 99648	1	Silenziatore (TE 250)	Exhaust silencer (TE 250)	Silencieux d'échapp. (TE 250)	Schalldämpfer (TE 250)	Silenciador de esc. (TE 250)	
	7	8000 A0395	1	Silenziatore (TE 250 USA)	Exhaust silencer (TE 250 USA)	Silenc. d'échapp. (TE 250 USA)	Schalldämpfer (TE 250 USA)	Silenc. de esc. (TE 250 USA)	
	7	8000 99949	1	Silenziatore (TC 250)	Exhaust silencer (TC 250)	Silencieux d'échapp. (TC 250)	Schalldämpfer (TC 250)	Silenciador de esc. (TC 250)	
	7	8000 A0395	1	Silenziatore (TC 250) (USA-CDN)	Exhaust silencer (TC 250) (USA-CDN)	Silencieux d'échapp. (TC 250) (USA-CDN)	Schalldämpfer (TC 250) (USA-CDN)	Silenciador de esc. (TC 250) (USA-CDN)	
	7	8000 A0416	1	Silenziatore (TE- SMR 450)	Exhaust silencer (TE- SMR 450)	Silencieux d'échapp. (TE- SMR 450)	Schalldämpfer (TE- SMR 450)	Silenciador de esc. (TE- SMR 450)	
	7	8000 A0408	1	Silenziatore (TE 450 USA)	Exhaust silencer (TE 450 USA)	Silenc. d'échapp. (TE 450 USA)	Schalldämpfer (TE 450 USA)	Silenc. de esc. (TE 450 USA)	
	7	8000 A0369	1	Silenziatore (TC 450)	Exhaust silencer (TC 450)	Silenc. d'échapp. (TC 450)	Schalldämpfer (TC 450)	Silenc. de esc. (TC 450)	
	7	8000 A0408	1	Silenziatore (TC 450) (USA-CDN)	Exhaust silencer (TC 450) (USA-CDN)	Silenc. d'échapp. (TC 450) (USA-CDN)	Schalldämpfer (TC 450) (USA-CDN)	Silenc. de esc. (TC 450) (USA-CDN)	
	8	8000 A0874	6	Molla	Spring	Ressort	Feder	Resorte	

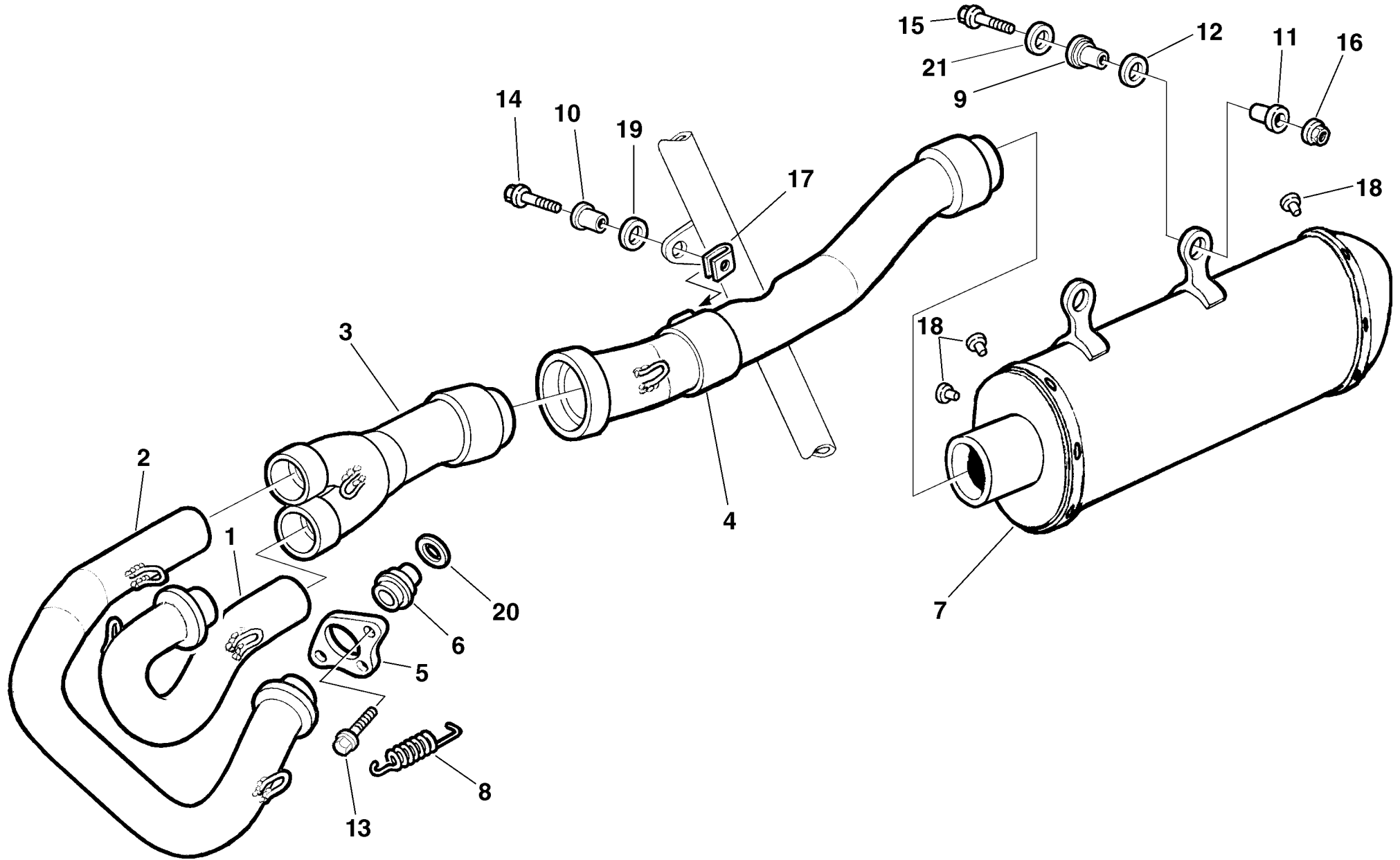



**TC-TE 250- 450,  
SM 400R-450R/ 2004**

TAVOLA  
DRAWING  
TABLE  
BILD  
TABLA

**28**

**SCARICO-EXHAUST SYSTEM  
TUYAU D'ECHAPPEMENT - AUSPUFFROHR  
TUBO DE ESCAPE**

Note Notes Markes Notas	Pos. No. N. Index Pos.	N. Cod. Code No. Nr. Code Code Nr N. Cod.	Q.tà Q.ty Q.te M.ge C.ad	DENOMINAZIONE	NAME	DESIGNATION	BESHREIBUNG	DENOMINACION	Validità Validity Validité Gültig Validez
<b>WC</b>	9	8G00 70379	2	Distanziale	Spacer	Entretoise	Distanzstück	Separador	
	10	8000 A0414	1	Distanziale	Spacer	Entretoise	Distanzstück	Separador	
	11	1514 03203	2	Rosetta in gomma	Rubber washer	Rondelle en caoutchouc	Gummischeibe	Arandela de goma	
	12	1513 41401	2	Rosetta in gomma	Rubber washer	Rondelle en caoutchouc	Gummischeibe	Arandela de goma	
	13	8000 62726	4	Vite (M6x14 mm)	Screw (M6x14 mm)	Vis (M6x14 mm)	Schraube (M6x14 mm)	Tornillo (M6x14 mm)	
	14	8000 62727	1	Vite (M6x16 mm)	Screw (M6x16 mm)	Vis (M6x16 mm)	Schraube (M6x16 mm)	Tornillo (M6x16 mm)	
	15	8000 62731	2	Vite (M6x45 mm)	Screw (M6x45 mm)	Vis (M6x45 mm)	Schraube (M6x45 mm)	Tornillo (M6x45 mm)	
	16	8000 44240	2	Dado	Nut	Ecrou	Mutter	Tuerca	
	17	8000 46893	1	Dado a graffetta	Nut	Ecrou	Mutter	Tuerca	
	18	8000 45042	2	Gommino	Rubber pad	Pièce caoutchouc	Gummistück	Junta de goma	
	19	8000 A1353	1	Gommino	Rubber pad	Pièce caoutchouc	Gummistück	Junta de goma	
	20	8000 A0873	2	Guarnizione (TE-TC 250)	Gasket (TE-TC 250)	Garnitue (TE-TC 250)	Dichtung (TE-TC 250)	Junta (TE-TC 250)	
	20	8A00 A0873	2	Guarnizione (TE-TC 450 - SMR)	Gasket (TE-TC 450 - SMR)	Garnitue (TE-TC 450 - SMR)	Dichtung (TE-TC 450 - SMR)	Junta (TE-TC 450 - SMR)	
	21	1513 74301	2	Rosetta	Washer	Rondelle	Scheibe	Arandela	

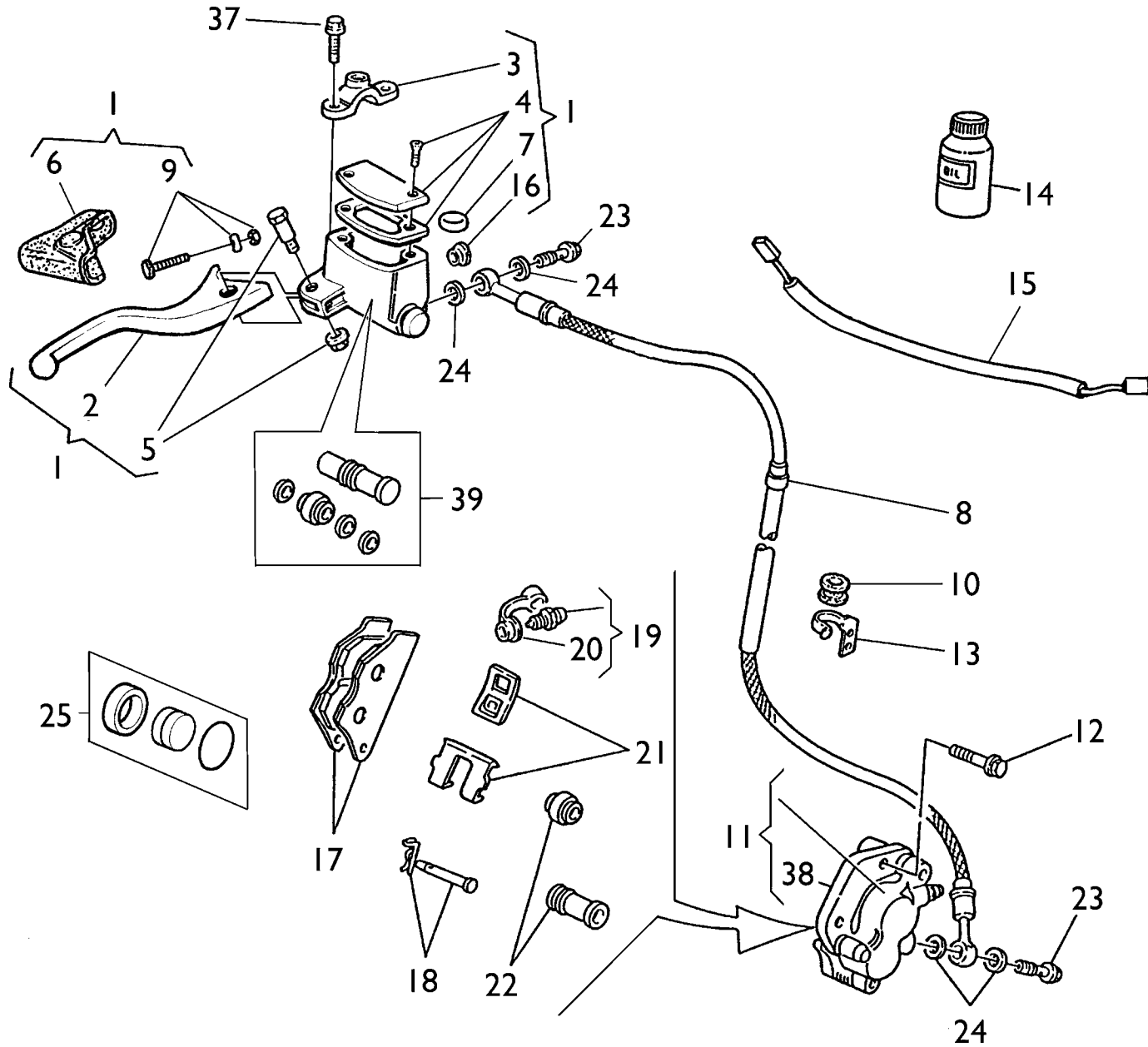



Note Notes Notas	Pos. No. Index	N. Cod. Code No. Nr. Code Code Nr N. Cod.	Q.tà Q.ty Q.te M.ge C.ad	DENOMINAZIONE	NAME	DESIGNATION	BESHREIBUNG	DENOMINACION	Validità Validity Validité Gültig Validez
<b>W</b>	1	8000 99715	1	Pompa comando freno ant.	Brake pump	Pompe frein	Bremspumpe	Bomba freno	
<b>CU</b>	1	8000 96831	1	Pompa comando freno ant.	Brake pump	Pompe frein	Bremspumpe	Bomba freno	
	2	8000 96830	1	Leva	Lever	Levier	Hebel	Palanca	
	3	8000 94125	1	Cavallotto	U-bolt	Cavalier	Bügelbolzen	Caballote	
	4	8000 94126	1	Kit tappo	Plug kit	Bouchon kit	Verschluss Gruppe	Kit tapón	
	5	8000 94127	1	Perno	Pin	Pivot	Bolzen	Perno	
	6	8000 94128	1	Cappuccio	Cap	Capuchon	Kappe	Capuchon	
	7	8000 79099	1	Antiemulsione	Antiemulsion	Antiemulsion	Eulsionwidriger	Antiemulsion	
<b>W</b>	8	8000 A0600	1	Tubo mandata olio	Hose	Tuyau	Rohr	Tubo	
<b>C</b>	8	8000 93036	1	Tubo mandata olio	Hose	Tuyau	Rohr	Tubo	
<b>W</b>	9	8000 94129	1	Regolazione	Adjuster	Registre	Regler	Regulizador	
<b>CU</b>	9	8000 A0927	1	Regolazione	Adjuster	Registre	Regler	Regulizador	
<b>CU</b>	10	8000 71806	1	Occhiello passatubo	Fairlead	Passe câble	Kabelführung	Prensa cable	
	11	8000 99674	1	Pinza freno	Brake caliper	Etrier frein	Bremssattel	Pinza	
	12	8000 62733	2	Vite	Screw	Vis	Schraube	Tornillo	
<b>CU</b>	13	8000 72022	1	Piastrina di ritegno	Plate	Plaque	Platte	Placa	
<b>R</b>	14	8000 71445	1	Olio freni	Brake oil	Huile frein	Bremsöl	Aceite freni	
<b>XW</b>	15	8000 A0929	1	Interruttore stop	Stop switch	Interrupteur stop	Stopschalter	Interruptor stop	
	16	8000 49654	1	Oblò	Inspection plug	Capuchon de inspection	Stopfen	Portilla	
	17	8000 96934	1	Coppia pastiglie	Pads pair	Paire plaquettes	Bremsbelagpaar	Pareja pastillas	
	18	8000 A0932	1	Perni	Pin	Pivot	Bolzen	Perno	
	19	8000 A0931	1	Spurgo	Spurgo	Drain	Entleerung	Purga	
	20	8000 53259	1	Parapolvere	Boots	Para-poudre	Schutzhaube	Para-polvo	
	21	8000 79065	1	Molla-lamierino	Spring-steel clip	Ressort	Feder	Rresorte	
	22	8000 79066	1	Cuffie	Boots	Poussiers	haube	Gorro	
	23	8000 57155	2	Vite	Screw	Vis	Schraube	Tornillo	
	24	8000 21480	4	Rosetta	Washer	Rondell'e	Scheibe	Arandela	
	25	8000 A0930	1	Pistone	Piston	Piston	Kolben	Pistón	
	37	8000 62729	2	Vite	Screw	Vis	Schraube	Tornillo	
	38	8000 99859	1	Supporto	Holder	Support	Halterung	Soporte	
<b>W</b>	39	8000 A0928	1	Flottante	Pin	Pivot	Bolzen	Perno	
<b>CU</b>	39	8000 A1137	1	Flottante	Pin	Pivot	Bolzen	Perno	

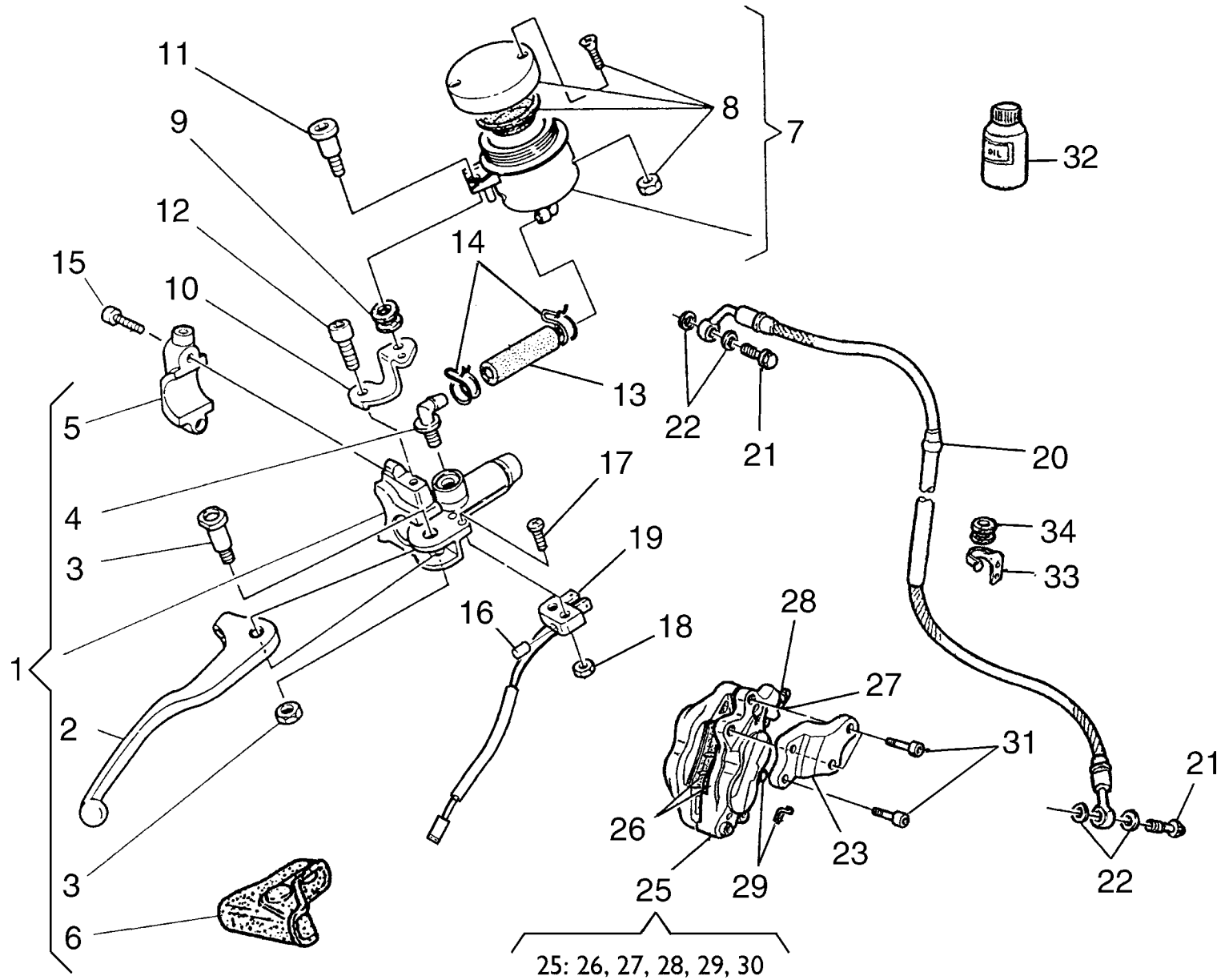

Note Notes Notas	Pos. No. Index Pos.	N. Cod. Code No. Nr. Code Code Nr N. Cod.	Q.tà Q.ty Q.te M.ge C.ad	DENOMINAZIONE	NAME	DESIGNATION	BESHREIBUNG	DENOMINACION	Validità Validity Validité Gültig Validez
	1	8000 A0694	1	Pompa comando freno ant.	Brake pump	Pompe frein	Bremspumpe	Bomba freno	
	2	80A0 52662	1	Leva	Lever	Levier	Hebel	Palanca	
	3	8000 46664	1	Gruppo revisione perno leva	Pin lever	Goujon levier	Bolzen Hebel	Perno palanca	
	4	8000 42345	1	Gruppo revisione raccordo	Connection set	Kit revision raccord	Anschluss repar. Stz	Grupo revis. empalme	
	5	8000 A0879	1	Cavallotto	U-bolt	Cavalier	Bügelbolzen	Caballete	
	6	8000 A0811	1	Cappuccio	Cap	Capuchon	Kappe	Capuchon	
	7	8000 66181	1	Serbatoio olio	Oil tank	Reservoir huile	Öltank	Depósito aceite	
	8	8000 68490	1	Gruppo revisione tappo	Plug set	Kit revision capuchon	Stopfensatz	Grupo revis. tapón	
	9	8000 33288	1	Antivibrante	Rubber pad	Pièce caoutchouc	Gummistück	Junta de goma	
	10	8A00 62714	1	Piastrina	Plate	Plaquette	Plättchen	Placa	
	11	8000 A1189	1	Vite	Screw	Vis	Schraube	Tornillo	
	12	8000 62725	1	Vite	Screw	Vis	Schraube	Tornillo	
	13	8G00 66179	1	Tubazione	Pipe	Tuyau	Rohr	Tubo	
	14	8000 18921	2	Anello SEEGER	SEEGER ring	Anneau SEEGER	Ring SEEGER	Anillo SEEGER	
	15	8000 62729	2	Vite (M6x25mm)	Screw (M6x25mm)	Vis (M6x25mm)	Schraube (M6x25mm)	Tornillo (M6x25mm)	
<b>X</b>	16	8000 55772	1	Nottolino	Pawl	Cliquet	Klinke	Pestillo	
<b>X</b>	17	60N1 07701	2	Vite	Screw	Vis	Schraube	Tornillo	
<b>X</b>	18	61N1 15501	2	Dado	Nut	Ecrou	Mutter	Tuerca	
<b>X</b>	19	8000 A0672	1	Interruttore stop	Stop switch	Interrupteur stop	Stopschalter	Interruptor stop	
<b>E</b>	20	8000 A0393	1	Tubo mandata olio	Pipe	Tuyau	Rohr	Tubo	
	20	8000 A1706	1	Tubo mandata olio	Pipe	Tuyau	Rohr	Tubo	
	21	8000 57155	2	Bocchettone	Pipe union	Goulotte	Stutzen	Boca	
	22	8000 21480	4	Rosetta di tenuta	Washer	Rondelle	Scheibe	Arandela	
	23	8000 A1708	1	Piastra	Plate	Plaque	Platte	Placa	
	24	8C00 62797	4	Vite (M10x35mm)	Screw (M10x35mm)	Vis (M10x35mm)	Schraube (M10x35mm)	Tornillo (M10x35mmmm)	
	25	8000 A1707	1	Pinza freno	Brake caliper	Etrier frein	Bremssattel	Pinza	
	26	8000 A2040	1	Coppia pastiglie	Pads pair	Paire plaquettes	Bremsbelagpaar	Pareja pastillas	
	27	8000 A2041	1	Vite di spurgo	Bleeding screw	Vis de curage	Reinigungsschraube	Tornillo de purga	
	28	8000 A2042	1	Parapolvere	Dust cover	Para poussière	Staubdeckel	Tapa retención polvo	
	29	8000 A2043	1	Kit perno copiglia	Pin kit	Kit pivot	Bolzensgruppe	Grupo perno	
<b>R</b>	32	8000 71445	1	Olio freni	Brake oil	Huile frein	BremsÖl	Aceite freni	
	33	8000 99299	1	Piastrina	Plate	Plaquette	Plättchen	Placa	
	34	8000 71806	1	Guida cavo	Cable guide	Guide câble	Kabelführung	Guía-cable	

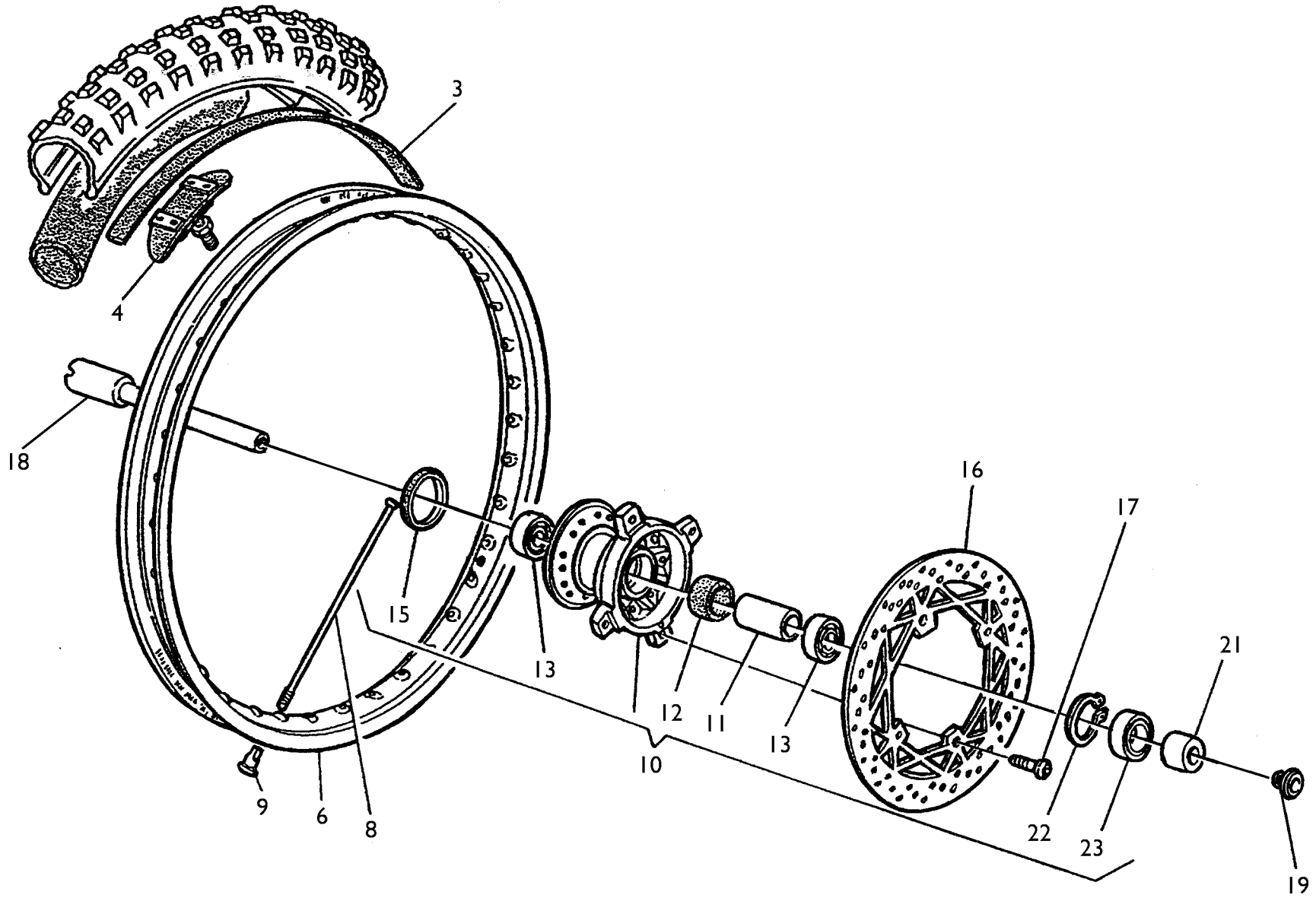



TC 250 - 450,  
TE 250 - 450 / 2004

TAVOLA  
DRAWING  
TABLE  
BILD  
TABLA

30

RUOTA ANTERIORE - FRONT WHEEL  
ROUE AV. - VORTERRAD  
RUEDA DELANTERA

Note Notes Marke Notas	Pos. No. N. Index Pos.	N. Cod. Code No. Nr. Code Code Nr N. Cod.	Q.tà Q.ty Q.te M.ge C.ad	DENOMINAZIONE	NAME	DESIGNATION	BESHREIBUNG	DENOMINACION	Validità Validity Validité Gültig Validez
	3	8000 13346	1	Fascia copriraggi	Rim strip	Bande	Band	Banda	
	4	8000 49036	1	Staffa fermacopertone	Bracket	Etrier	Buegel	Brida	
	6	8A00 53504	1	Cerchio (1,6x21")	Rim (1,6x21")	Jante (1,6x21")	Felge (1,6x21")	Llanta (1,6x21")	
	8	8000 A0080	36	Raggio	Spoke	Bras	Speiche	Radio	
	9	8000 A0081	36	Nipplo	Nipple	Nipple	Nippel	Nipple	
	10	8000 96838	1	Mozzo completo	Hub assy	Moyeau compl.	Radnabe, Kpl.	Cubo compl.	
	11	8000 96928	1	Distanziale	Spacer	Entretoise	Distanzstück	Separador	
	12	8000 92797	1	Portadistanziale	Spacer holder	Porte-entretoise	Abstandstückhalter	Porta-distancial	
	13	8000 84938	2	Cuscinetto a sfere (ø25xø42x9 mm)	Ball bearing (ø25xø42x9 mm)	Roulement à billes (ø25xø42x9 mm)	Kugellager (ø25xø42x9 mm)	Cojinete de bolas (ø25xø42x9 mm)	
	15	8A00 92986	1	Anello di tenuta (ø28xø50x5 mm)	Seal ring (ø28xø50x5 mm)	Bague d'étanchéité (ø28xø50x5 mm)	Dichtungsring (ø28xø50x5 mm)	Anillo de retención (ø28xø50x5 mm)	
	16	8000 99632	1	Disco freno (ø260 mm)	Brake disc (ø260 mm)	Disque frein (ø260 mm)	Bremsscheibe (ø260 mm)	Disco freno (ø260 mm)	
	17	8A00 55241	4	Vite	Screw	Vis	Schraube	Tornillo	
	18	8000 96932	1	Perno ruota	Pin	Pivot	Bolzen	Perno rueda	
	19	8000 96933	1	Vite	Screw	Vis	Schraube	Tornillo	
	21	8000 96930	1	Distanziale	Spacer	Entretoise	Distanzstück	Separador	
	22	66N0 21270	1	Anello SEEGER	SEEGER ring	Anneau SEEGER	Ring SEEGER	Anillo SEEGER	
	23	8000 22966	1	Anello di tenuta (ø32xø42x7 mm)	Seal ring (ø32xø42x7 mm)	Bague d'étanchéité (ø32xø42x7 mm)	Dichtungsring (ø32xø42x7 mm)	Anillo de retención (ø32xø42x7 mm)	

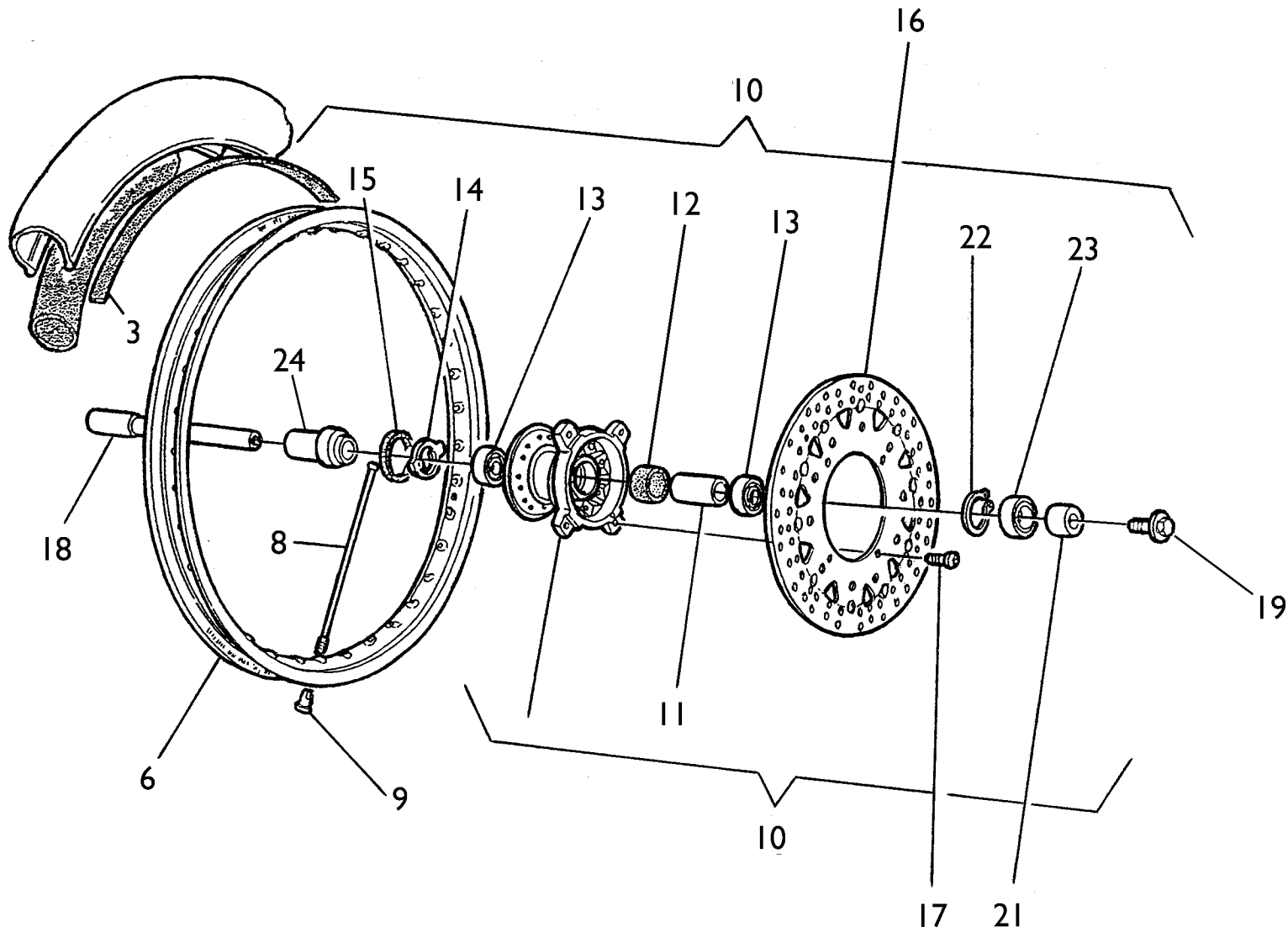



Note Notes Marke Notas	Pos. No. N. Index Pos.	N. Cod. Code No. Nr. Code Code Nr N. Cod.	Q.tà Q.ty M.ge C.ad	DENOMINAZIONE	NAME	DESIGNATION	BESHREIBUNG	DENOMINACION	Validità Validity Validité Gültig Validez
	3	8B00 82879	1	Fascia copriraggi	Rim strip	Bande	Band	Banda	
	6	8000 94709	1	Cerchio (3,5x17") (BEHR)	Rim (3,5x17") (BEHR)	Jante (3,5x17") (BEHR)	Felge (3,5x17") (BEHR)	Llanta (3,5x17") (BEHR)	
	6	8000 91525	1	Cerchio (3,5x17") (S.REMO)	Rim (3,5x17") (S.REMO)	Jante (3,5x17") (S.REMO)	Felge (3,5x17") (S.REMO)	Llanta (3,5x17") (S.REMO)	
	8	8000 94754	36	Raggio	Spoke	Bras	Speiche	Radio	
	9	69N4 29004	36	Nipplo	Nipple	Nipple	Nippel	Nipple	
	10	8B00 96838	1	Mozzo completo	Hub assy	Moyeau compl.	Radnabe, Kpl.	Cubo compl.	
	11	8000 95628	1	Distanziale	Spacer	Entretoise	Distanzstück	Separador	
	12	8000 92797	1	Portadistanziale	Spacer holder	Porte-entretoise	Abstandstuckhalter	Porta-distancial	
	13	8000 84938	2	Cuscinetto a sfere	Ball bearing	Roulement à billes	Kugellager	Cojinete de bolas	
				(ø25xø42x9mm)	(ø25xø42x9mm)	(ø25xø42x9mm)	(ø25xø42x9mm)	(ø25xø42x9mm)	
	15	8A00 92986	1	Anello di tenuta	Seal ring	Bague d'étanchéité	Dichtungsring	Anillo de retención	
				(ø42xø50x9mm)	(ø42xø50x9mm)	(ø42xø50x9mm)	(ø42xø50x9mm)	(ø42xø50x9mm)	
	16	8000 A1709	1	Disco freno (ø320mm)	Brake disc (ø320mm)	Disque frein (ø320mm)	Bremsscheibe (ø320mm)	Disco freno (ø320mm)	
	17	8A00 92876	4	Vite	Screw	Vis	Schraube	Tornillo	
	18	8A00 96932	1	Perno ruota	Pin	Pivot	Bolzen	Perno rueda	
	19	8000 96933	1	Vite	Screw	Vis	Schraube	Tornillo	
	21	8A00 96930	1	Parapolvere	Dust guard	Pare poussière	Staubdeckel	Tapa retención polvo	
	22	66N0 21270	1	Anello SEEGER	SEEGER ring	Anneau SEEGER	Ring SEEGER	Anillo SEEGER	
	23	8000 22966	1	Distanziale	Spacer	Entretoise	Distanzstück	Separador	
				D42-d32-Sp7	D42-d32-Th7	D42-d32-ép7	D42-d32-S7	D42-d32-esp7	

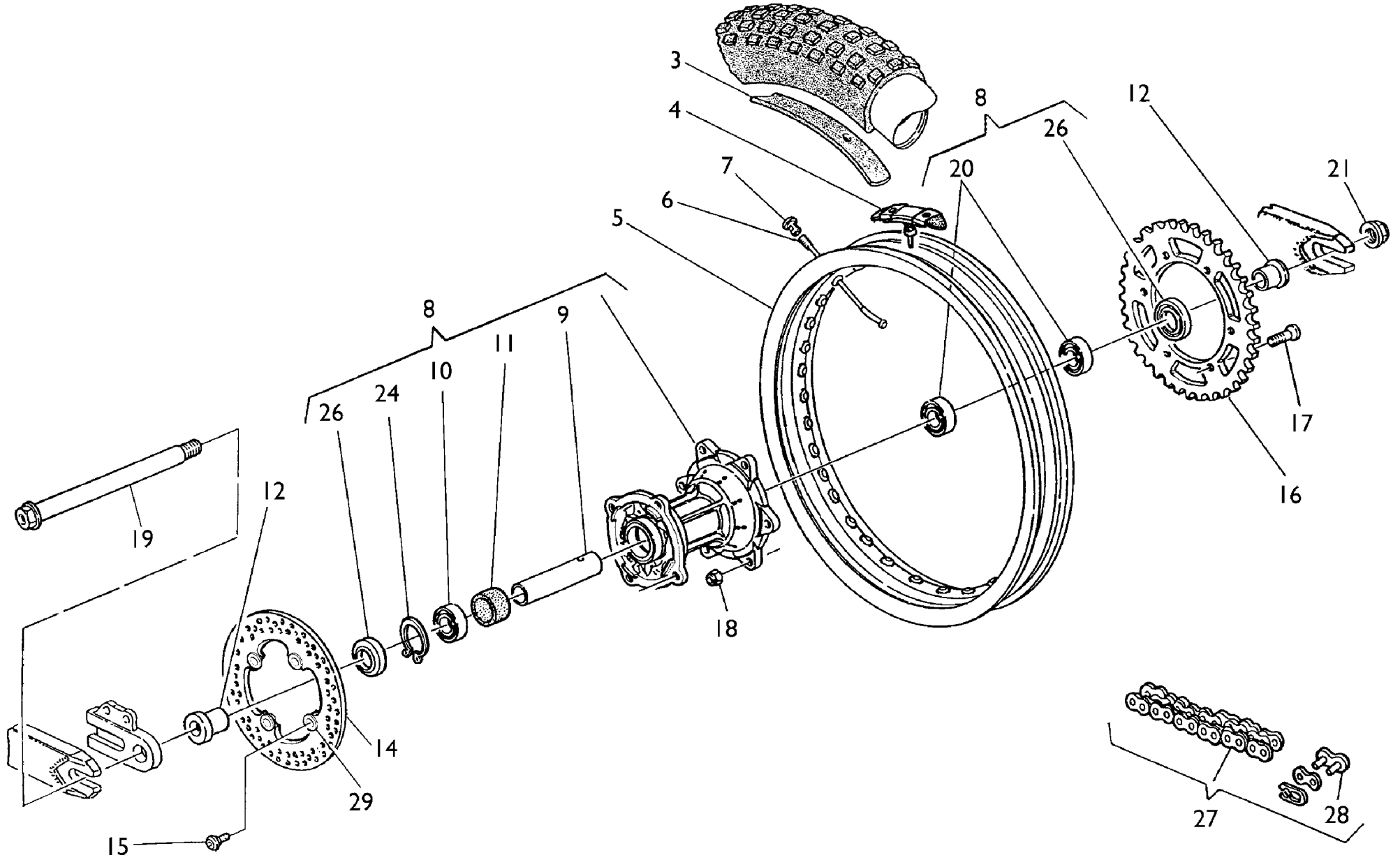



**TC-TE 250- 450,  
SM 400R-450R/ 2004**

TAVOLA  
DRAWING  
TABLE  
BILD  
TABLA

**31**

**RUOTA POSTERIORE - REAR WHEEL  
ROUE ARRIERE - HINTERRAD  
RUEDA TRASERA**

Note Notes Markes Notas	Pos. No. N. Index Pos.	N. Cod. Code No. Nr. Code Code Nr N. Cod.	Q.tà Q.ty Q.te M.ge C.ad	DENOMINAZIONE	NAME	DESIGNATION	BESHREIBUNG	DENOMINACION	Validità Validity Validité Gültig Validez
<b>W</b>	3	8000 01688	1	Fascia copriraggi	Rim strip	Bande	Band	Banda	
<b>C</b>	3	8000 10777	1	Fascia copriraggi	Rim strip	Bande	Band	Banda	
<b>M</b>	3	8B00 82879	1	Fascia copriraggi	Rim strip	Bande	Band	Banda	
	4	8000 54073	1	Staffa fermacopertone (TE 250-450, TC 450)	Bracket (TE 250-450, TC 450)	Etrier (TE 250-450, TC 450)	Buegel (TE 250-450, TC 450)	Brida (TE 250-450, TC 450)	
	4	8000 49035	1	Staffa fermacopertone (TC 250)	Bracket (TC 250)	Etrier (TC 250)	Buegel (TC 250)	Brida (TC 250)	
	5	8A00 55860	1	Cerchio (2,15 x 18") (TE 250-450)	Rim (2,15 x 18") (TE 250-450)	Jante (2,15 x 18") (TE 250-450)	Felge (2,15 x 18") (TE 250-450)	Llanta (2,15 x 18") (TE 250-450)	
	5	8A00 58930	1	Cerchio (2,15 x 18") (TC 250)	Rim (2,15 x 18") (TC 250)	Jante (2,15 x 18") (TC 250)	Felge (2,15 x 18") (TC 250)	Llanta (2,15 x 18") (TC 250)	
	5	8A00 58929	1	Cerchio (2,15 x 18") (TC 450)	Rim (2,15 x 18") (TC 450)	Jante (2,15 x 18") (TC 450)	Felge (2,15 x 18") (TC 450)	Llanta (2,15 x 18") (TC 450)	
<b>M</b>	5	8000 94713	1	Cerchio (4,25 x 17") (BEHR)	Rim (4,25 x 17") (BEHR)	Jante (4,25 x 17") (BEHR)	Felge (4,25 x 17") (BEHR)	Llanta (4,25 x 17") (BEHR)	
<b>M</b>	5	8000 92612	1	Cerchio (4,25 x 17") (S.REMO)	Rim (4,25 x 17") (S.REMO)	Jante (4,25 x 17") (S.REMO)	Felge (4,25 x 17") (S.REMO)	Llanta (4,25 x 17") (S.REMO)	
<b>W</b>	6	8000 A0085	36	Raggio	Spoke	Bras	Speiche	Radio	
<b>C</b>	6	8A00 A0085	36	Raggio	Spoke	Bras	Speiche	Radio	
<b>M</b>	6	8000 94757	36	Raggio	Spoke	Bras	Speiche	Radio	
<b>WC</b>	7	8000 A0086	36	Nipplo	Nipple	Nipple	Nippel	Nipple	
<b>M</b>	7	69N4 29005	36	Nipplo	Nipple	Nipple	Nippel	Nipple	
<b>WC</b>	8	8A00 96937	1	Mozzo completo	Hub assy	Moyeau compl.	Radnabe, Kpl.	Cubo compl.	
<b>M</b>	8	8A00 97593	1	Mozzo completo	Hub assy	Moyeau compl.	Radnabe, Kpl.	Cubo compl.	
<b>WC</b>	9	8000 92414	1	Distanziale	Spacer	Entretoise	Distanzstück	Separador	
<b>M</b>	9	8A00 86938	1	Distanziale	Spacer	Entretoise	Distanzstück	Separador	
	10	8B00 26846	1	Cuscinetto(ø25xø47x16 mm)	Bearing (ø25xø47x16 mm)	Roulement (ø25xø47x16 mm)	Kugellager (ø25xø47x16 mm)	Cojinete (ø25xø47x16 mm)	
<b>MA</b>	10	8D00 26846	1	Cuscinetto(ø25xø47x16 mm)	Bearing (ø25xø47x16 mm)	Roulement (ø25xø47x16 mm)	Kugellager (ø25xø47x16 mm)	Cojinete (ø25xø47x16 mm)	
	11	8000 92797	1	Porta distanziale	Spacer	Entretoise	Distanzstück	Separador	
<b>Y</b>	12	8000 96938	2	Distanziale	Spacer	Entretoise	Distanzstück	Separador	
<b>C</b>	12	8A00 96938	1	Distanziale (lato freno)	Spacer (brake side)	Entretoise (côte frein)	Distanzstück (Bremse Seite)	Separador (lado freno)	
<b>C</b>	12	8000 96938	1	Distanziale (lato corona)	Spacer (ring gear side)	Entretoise (côte couronne)	Distanzstück (Kranz Seite)	Separador (lado corona)	
<b>WC</b>	14	8000 A0692	1	Disco freno (ø220 mm)	Brake disc (ø220 mm)	Disque frein (ø220 mm)	Bremsscheibe (ø220 mm)	Disco freno (ø220 mm)	
<b>M</b>	14	8000 88887	1	Disco freno (ø220 mm)	Brake disc (ø220 mm)	Disque frein (ø220 mm)	Bremsscheibe (ø220 mm)	Disco freno (ø220 mm)	
<b>WC</b>	15	8000 62726	4	Vite	Screw	Vis	Schraube	Tornillo	

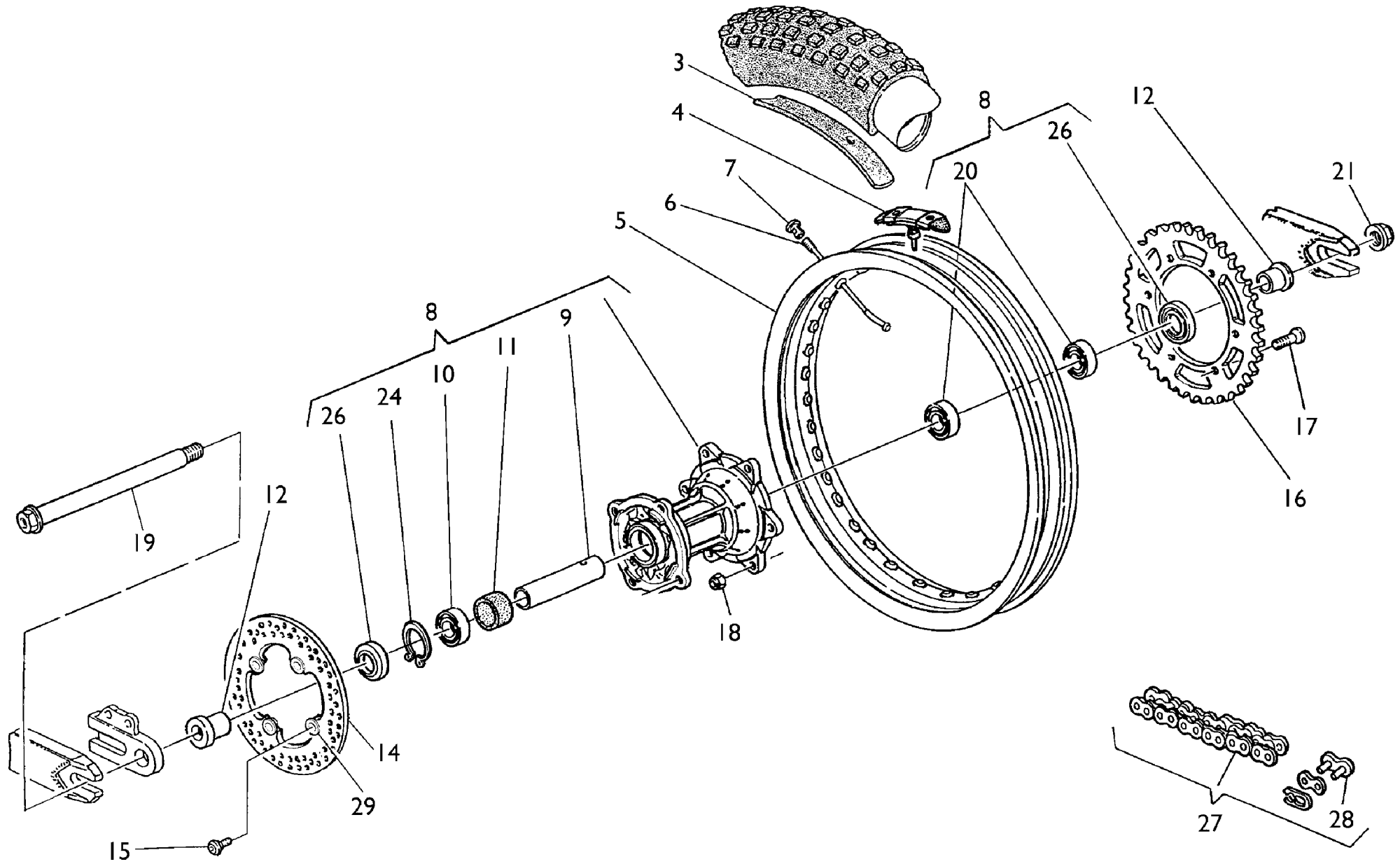



TC-TE 250- 450,  
SM 400R-450R/ 2004

TAVOLA  
DRAWING  
TABLE  
BILD  
TABLA

31

RUOTA POSTERIORE - REAR WHEEL  
ROUE ARRIERE - HINTERRAD  
RUEDA TRASERA

Note Notes Marka Notas	Pos. No. Index Pos.	N. Cod. Code No. Nr. Code Code Nr N. Cod.	Q.tà Q.ty M.ge C.ad	DENOMINAZIONE	NAME	DESIGNATION	BESHREIBUNG	DENOMINACION	Validità Validity Validité Gültig Validez
<b>M</b>	15	8000 55878	4	Vite	Screw	Vis	Schraube	Tornillo	
<b>M</b>	16	8G00 96837	1	Corona (Z = 45)	Ring gear (Z = 45)	Couronne (Z = 45)	Kranz (Z = 45)	Corona (Z = 45)	
<b>R</b>	16	8000 96837	1	Corona (Z = 46)	Ring gear (Z = 46)	Couronne (Z = 46)	Kranz (Z = 46)	Corona (Z = 46)	
<b>RWC</b>	16	8A00 96837	1	Corona (Z = 47)	Ring gear (Z = 47)	Couronne (Z = 47)	Kranz (Z = 47)	Corona (Z = 47)	
<b>RWC</b>	16	8B00 96837	1	Corona (Z = 48)	Ring gear (Z = 48)	Couronne (Z = 48)	Kranz (Z = 48)	Corona (Z = 48)	
<b>RWC</b>	16	8C00 96837	1	Corona (Z = 49)	Ring gear (Z = 49)	Couronne (Z = 49)	Kranz (Z = 49)	Corona (Z = 49)	
<b>WC</b>	16	8D00 96837	1	Corona (Z = 50)	Ring gear (Z = 50)	Couronne (Z = 50)	Kranz (Z = 50)	Corona (Z = 50)	
	17	8000 40796	6	Vite	Screw	Vis	Schraube	Tornillo	
	18	8000 43928	6	Dado	Nut	Ecrou	Mutter	Tuierca	
	19	8000 96940	1	Perno	Pin	Pivot	Bolzen	Perno	
	20	8A00 26846	2	Cuscinetto (ø25xø47x12 mm)	Bearing (ø25xø47x12 mm)	Roulement (ø25xø47x12 mm)	Kugellager (ø25xø47x12 mm)	Cojinete (ø25xø47x12 mm)	
<b>MA</b>	20	8C00 26846	2	Cuscinetto (ø25xø47x12 mm)	Bearing (ø25xø47x12 mm)	Roulement (ø25xø47x12 mm)	Kugellager (ø25xø47x12 mm)	Cojinete (ø25xø47x12 mm)	
	21	8000 93072	1	Dado	Nut	Ecrou	Mutter	Tuerca	
	24	66N0 21272	1	Anello SEEGER	SEEGER ring	Anneau SEEGER	Ring SEEGER	Anillo SEEGER	
	26	8000 89572	2	Anello di tenuta Ø32xø47x7	Seal ring Ø32xø47x7	Bague d'étanch. Ø32xø47x7	Dichtungsring Ø32xø47x7	Anillo de retenc. Ø32xø47x7	
<b>W</b>	27	8B00 65442	1	Catena 5/8"x6,5 (114 maglie)	Chain 5/8"x6,5 (114 link)	Chaîne 5/8"x6,5 (114 maillon)	Kette 5/8"x6,5 (114 Schake)	Cadena 5/8"x6,5 (114 malla)	
<b>WA</b>	27	8B00 79783	1	Catena 5/8"x6,5 (114 maglie)	Chain 5/8"x1/4"(114 link)	Chaîne 5/8"x6,5 (114 maillon)	Kette 5/8"x6,5 (114 Schake)	Cadena 5/8"x6,5 (114 malla)	
	27	8000 56768	1	Catena 5/8"x6,5 (114 maglie)	Chain 5/8"x1/4"(114 link)	Chaîne 5/8"x6,5 (114 maillon)	Kette 5/8"x6,5 (114 Schake)	Cadena 5/8"x6,5 (114 malla)	
				(TC 250)					
<b>A</b>	27	8B00 79785	1	Catena 5/8"x6,5 (114 maglie)	Chain 5/8"x1/4"(114 link)	Chaîne 5/8"x6,5 (114 maillon)	Kette 5/8"x6,5 (114 Schake)	Cadena 5/8"x6,5 (114 malla)	
				(TC 250)					
	27	8C00 56768	1	Catena 5/8"x6,5 (116 maglie)	Chain 5/8"x1/4"(116 link)	Chaîne 5/8"x6,5 (116 maillon)	Kette 5/8"x6,5 (116 Schake)	Cadena 5/8"x6,5 (116 malla)	
				(TC 450)					
<b>A</b>	27	8F00 79785	1	Catena 5/8"x6,5 (116 maglie)	Chain 5/8"x1/4"(116 link)	Chaîne 5/8"x6,5 (116 maillon)	Kette 5/8"x6,5 (116 Schake)	Cadena 5/8"x6,5 (116 malla)	
				(TC 450)					
<b>M</b>	27	8000 65442	1	Catena 5/8"x6,5 (112 maglie)	Chain 5/8"x6,5 (112 link)	Chaîne 5/8"x6,5 (112 maillon)	Kette 5/8"x6,5 (112 Schake)	Cadena 5/8"x6,5 (112 malla)	
<b>MA</b>	27	8E00 79783	1	Catena 5/8"x6,5 (112 maglie)	Chain 5/8"x1/4"(112 link)	Chaîne 5/8"x6,5 (112 maillon)	Kette 5/8"x6,5 (112 Schake)	Cadena 5/8"x6,5 (112 malla)	
<b>WM</b>	28	8000 65464	1	Giunto	Coupling	Joint	Kupplung	Junta	
<b>WMA</b>	28	8000 79789	1	Giunto	Coupling	Joint	Kupplung	Junta	
<b>C</b>	28	8000 56767	1	Giunto	Coupling	Joint	Kupplung	Junta	
<b>CA</b>	28	8000 79790	1	Giunto	Coupling	Joint	Kupplung	Junta	
<b>WC</b>	29	8000 A0693	4	Bussola	Bushing	Douille	Buchse	Manguito	

SEE TABLE no. 20

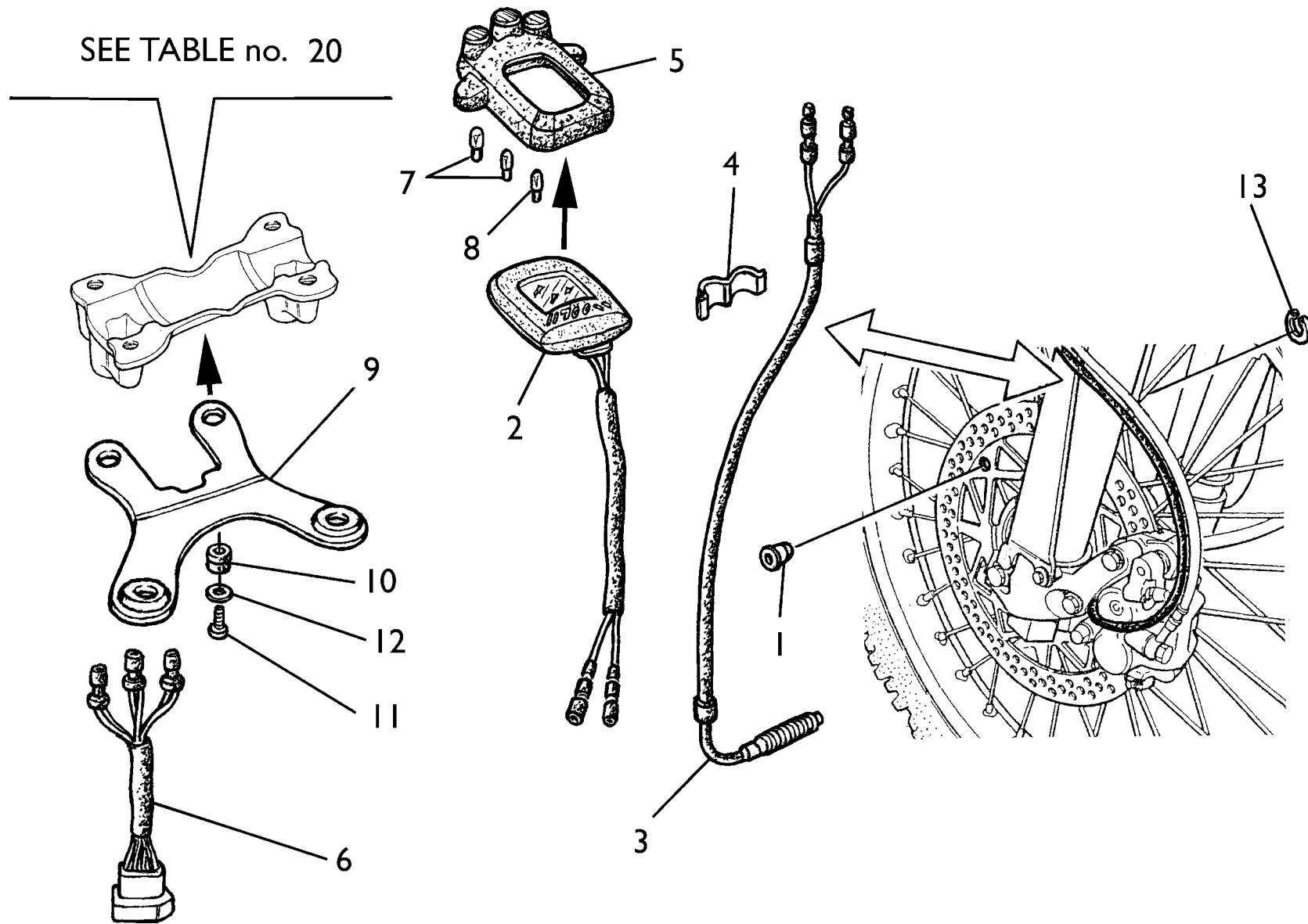





TE 250-450,  
SM 400R-450R / 2004

TAVOLA  
DRAWING  
TABLE  
BILD  
TABLA

32

STRUMENTO DIGITALE-DIGITAL INSTRUMENT-INSTRUMENT DIGITAL -  
DIGITAL TACHOMETER-INSTRUMENTO DIGITAL

Note Notes Mark Notas	Pos. No. N. Index Pos.	N. Cod. Code No. Nr. Code Code Nr N. Cod.	Q.tà Q.ty Q.te M.ge C.ad	DENOMINAZIONE	NAME	DESIGNATION	BESHREIBUNG	DENOMINACION	Validità Validity Validité Gültig Validez
<b>WX</b>	1	8000 99775	1	Magnete	Magnet	Amiant	Magnet	Imán	
<b>MX</b>	1	8000 A0843	1	Magnete	Magnet	Amiant	Magnet	Imán	
<b>X</b>	2	8000 99650	1	Contachilometri digitale	Digital speedometer	Compteur-km digital	Digital Tachometer	Cuenta-kilómetros digital	
<b>X</b>	3	8000 99652	1	Sensore magnetico	Sensor	Palpeur	Sensor	Sensor	
<b>X</b>	4	8000 A0664	2	Molletta	Clip	Collier	Schelle	Banda	
<b>X</b>	5	8000 A0883	1	Supporto spie	Holder	Support	Halterung	Soporte	
<b>X</b>	6	8000 99651	1	Gruppo cavi	Cable assy	Cables compl.	Kabel Kpl.	Grupo cables	
<b>X</b>	7	8000 20602	2	Lampadina (12V-1,2 W)	Lamp (12V-1,2 W)	Lampe (12V-1,2 W)	Lampe (12V-1,2 W)	Lamparilla (12V-1,2 W)	
<b>X</b>	8	8000 60033	2	Lampadina (12V-2 W)	Lamp (12V-2 W)	Lampe (12V-2 W)	Lampe (12V-2 W)	Lamparilla (12V-2 W)	
<b>X</b>	9	80A0 99774	1	Piastra	Plate	Plaque	Platte	Placa	
<b>X</b>	10	8000 41862	2	Passacavo	Fairlead	Passe-câble	Kabelführung	Prensa-cable	
<b>X</b>	11	8000 89069	2	Vite	Screw	Vis	Schraube	Tornillo	
<b>X</b>	12	62N4 15548	2	Rosetta	Washer	Rondelle	Scheibe	Arandela	
<b>WX</b>	13	66N0 21200	1	Anello elastico	Snap ring	Bague d'arret	Haltering	Anillo elástico	
<b>MX</b>	13	66N0 21197	1	Anello elastico	Snap ring	Bague d'arret	Haltering	Anillo elástico	

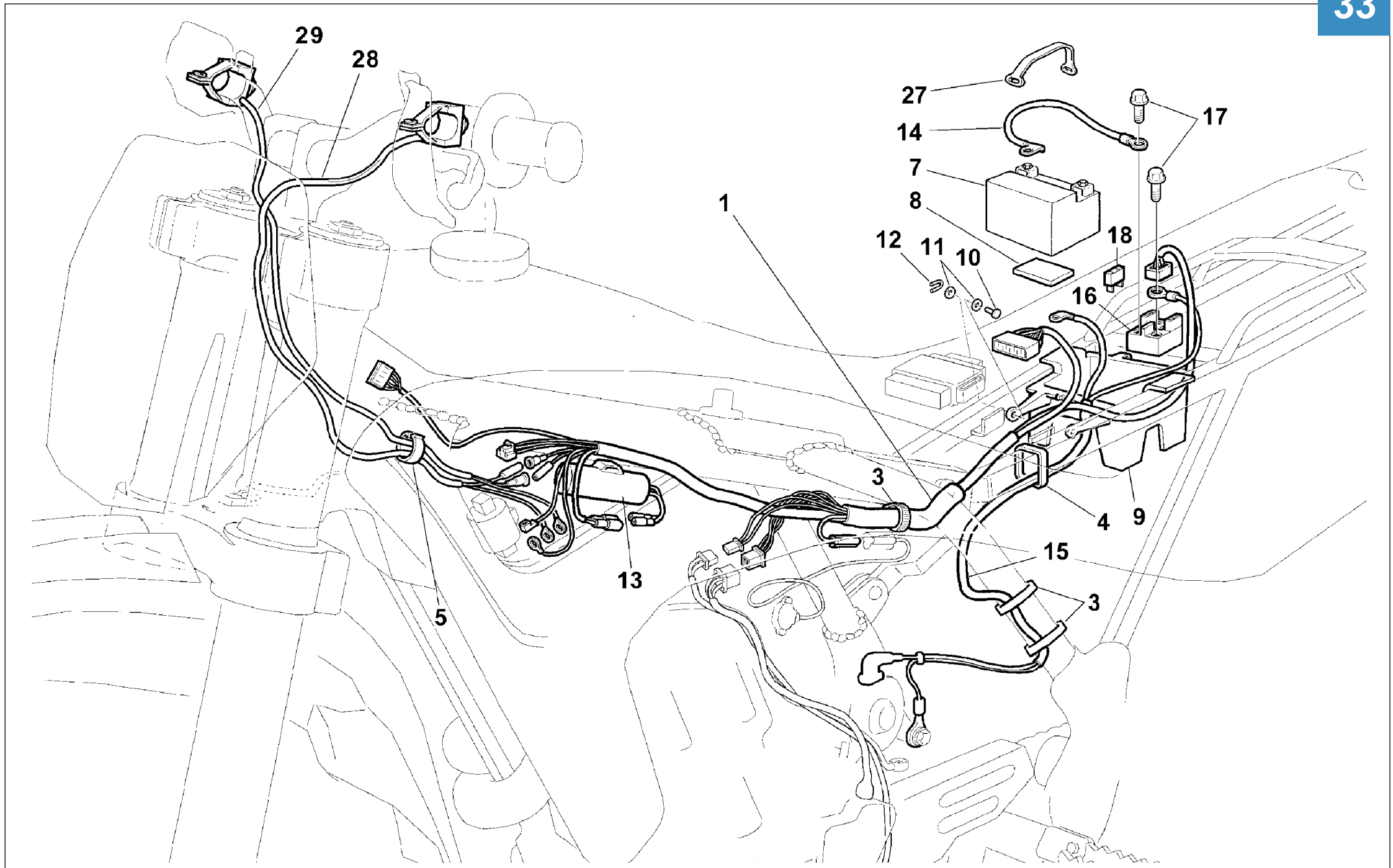

Note Notes Notas	Pos. No. Index Pos.	N. Cod. Code No. Nr. Code Code Nr N. Cod.	Q.tà Q.ty Q.te M.ge C.ad	DENOMINAZIONE	NAME	DESIGNATION	BESHREIBUNG	DENOMINACION	Validità Validity Validité Gültig Validez
	1	8000 A1433	1	Gruppo principale cavi (TC 250)	Cable assy (TC 250)	Cables compl. (TC 250)	Kabel Kpl. (TC 250)	Grupo prin. cables (TC 250)	
	1	8000 91981	1	Gruppo principale cavi (TC 450, TE USA-SMR USA)	Cable assy (TC 450, TE USA-SMR USA)	Cables compl. (TC 450, TE USA-SMR USA)	Kabel Kpl. (TC 450, TE USA-SMR USA)	Grupo prin. cables (TC 450, TE USA-SMR USA)	
	3	8000 56444	8	Fascetta (L=188 mm)	Clamp (L=188 mm)	Collier (L=188 mm)	Schelle (L=188 mm)	Banda (L=188 mm)	
	4	8000 56783	5	Fascetta (L=142mm)	Clamp (L=142mm)	Collier (L=142mm)	Schelle (L=142mm)	Banda (L=142mm)	
	5	8000 58207	2	Passacavo	Fairlead	Passe-câble	Kabelführung	Prensa-cable	
	7	8000 A0993	1	Batteria (2,3Ah) (TC 250)	Battery (2,3Ah) (TC 250)	Batterie (2,3Ah) (TC 250)	Batterie (2,3Ah) (TC 250)	Batería (2,3Ah) (TC 250)	
	7	8000 A1891	1	Batteria (2,3Ah) (TE 250, 400-450)	Battery (2,3Ah) (TE 250, 400-450)	Batterie (2,3Ah) (TE 250, 400-450)	Batterie (2,3Ah) (TE 250, 400-450)	Batería (2,3Ah) (TE 250, 400-450)	
	8	8000 A1280	1	Spessore elastico	Rubber spacer	Entretoise	Distanzstück	Espesor	
	9	8000 A0071	1	Contentitore batteria	Battery holder	Conteneur batterie	Batterie Behaelter	Contenedor batería	
	10	8A00 41459	2	Perno	Pin	Pivot	Bolzen	Perno	
	11	8A00 06911	4	Rosetta	Washer	Rondelle	Scheibe	Arandela	
	12	8000 62705	2	Spinetta	Pin	Goupille	Stift	Clavija	
	13	8000 A0107	1	Condensatore	Condenser	Condensateur	Kondensator	Condensador	
	14	8000 A0994	1	Cavo batteria-teleruttore (TC 250)	Battery-Remote switch cable (TC 250)	Cable batterie-telerupteur (TC 250)	Kabel Batterie-Fernshalter (TC 250)	Cable Batería-Telerruptor (TC 250)	
	14	8000 A0110	1	Cavo batteria-teleruttore (TC 450, TE USA-SMR USA)	Battery-Remote switch cable (TC 450, TE USA-SMR USA)	Cable batterie-telerupteur (TC 450, TE USA-SMR USA)	Kabel Batterie-Fernshalter (TC 450, TE USA-SMR USA)	Cable Batería-Telerruptor (TC 450, TE USA-SMR USA)	
	15	8000 A0995	1	Cavo motorino avviamento (TC 250)	Starting motor cable (TC 250)	Cable moteur demarrage (TC 250)	Anlasser motor kabel (TC 250)	Cable motor de arranque (TC 250)	
	15	8000 A0111	1	Cavo motorino avviamento (TC 450, TE USA-SMR USA)	Starting motor cable (TC 450, TE USA-SMR USA)	Cable moteur demarrage (TC 450, TE USA-SMR USA)	Anlasser motor kabel (TC 450, TE USA-SMR USA)	Cable motor de arranque (TC 450, TE USA-SMR USA)	
	16	8000 91115	1	Teleruttore avviamento	Remote switch	Telerupteur	Fernshalter	Telerruptor	
	17	8SA0 67545	2	Vite	Screw	Vis	Schraube	Tornillo	
	18	8000 47472	1	Fusibile (15A)	Fuse (15A)	Fusible (15A)	Sicherung (15A)	Fusible (15A)	
	26	8000 A0992	3	Spessore elastico (TC 250)	Rubber spacer (TC 250)	Entretoise(TC 250)	Distanzstück (TC 250)	Espesor (TC 250)	
	27	8000 88181	1	Elastico	Elastic	Elastique	Elastisch	Elástico	
	28	8000 A0731	1	Pulsante arresto motore	Engine stop button	Poussoir arret moteur	Knopf	Pùlsador parada motor	
	29	8000 A0732	1	Pulsante avviamento motore	Engine start button	Poussoir demarrage moteur	Knopf	Pùlsador arranque motor	

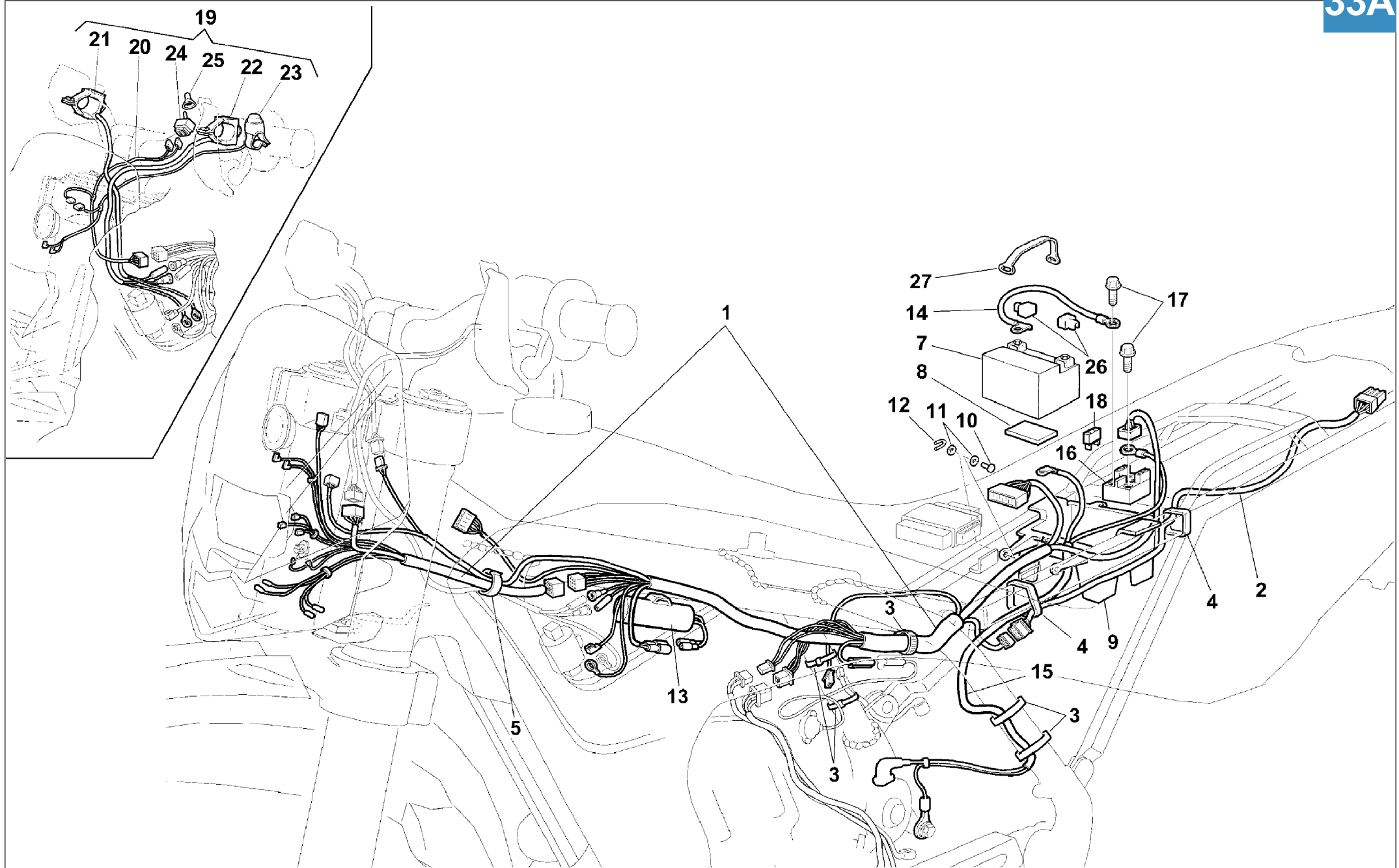



TE 250- 450,  
SM 400R-450R/ 2004

TAVOLA  
DRAWING  
TABLE  
BILD  
TABLA

33A

GRUPPO CAVI, PARTI ELETTRICHE - MAIN WIRING HARNESS, ELECTRICAL PARTS -  
CABLES PRINCIPAL, PARTIES ELECTRIQUES - KABEL, ELEKTRISCHE KOMPONENTE -  
GRUPO PRINCIPAL CABLES, PARTES ELECTRICAS

Note Notes Marke Notas	Pos. No. N. Index Pos.	N. Cod. Code No. Nr. Code Code Nr N. Cod.	Q.tà Q.ty M.ge C.ad	DENOMINAZIONE	NAME	DESIGNATION	BESHREIBUNG	DENOMINACION	Validità Validity Validité Gültig Validez
	1	8000 99622	1	Gruppo principale cavi	Cable assy	Cables compl.	Kabel Kpl.	Grupo principal cables	
<b>X</b>	2	8000 70277	1	Cavo posteriore	Cable	Cable	Kabel	Cable	
	3	8000 56444	8	Fascetta (L=188 mm)	Clamp (L=188 mm)	Collier (L=188 mm)	Schelle (L=188 mm)	Banda (L=188 mm)	
	4	8000 56783	6	Fascetta (L=142mm)	Clamp (L=142mm)	Collier (L=142mm)	Schelle (L=142mm)	Banda (L=142mm)	
	5	8000 58207	2	Passacavo	Fairlead	Passe-câble	Kabelführung	Prensa-cable	
<b>X</b>	6	8000 72494	1	Passacavo	Fairlead	Passe-câble	Kabelführung	Prensa-cable	
<b>E</b>	7	8000 99627	1	Batteria (4Ah)	Battery (4Ah)	Batterie (4Ah)	Batterie (4Ah)	Bateria (4Ah)	
	7	8000 A1891	1	Batteria (6Ah)	Battery (6Ah)	Batterie (6Ah)	Batterie (6Ah)	Bateria (6Ah)	
	8	8000 A1280	1	Spessore elastico	Rubber spacer	Entretoise	Distanzstück	Espesor	
	9	8000 A0071	1	Contenitore batteria	Battery holder	Conteneur batterie	Batterie Behaelter	Contenedor batería	
	10	8A00 41459	2	Perno	Pin	Pivot	Bolzen	Perno	
	11	8A00 06911	4	Rosetta	Washer	Rondelle	Scheibe	Arandela	
	12	8000 62705	2	Spinetta	Pin	Goupille	Stift	Clavija	
	13	8000 A0107	1	Condensatore	Condenser	Condensateur	Kondensator	Condensador	
	14	8000 A0110	1	Cavo batteria-teleruttore	Battery-Remote switch cable	Cable batterie-telerupteur	Kabel Batterie-Fernshalter	Cable Bateria-Telerruptor	
	15	8000 A0111	1	Cavo motorino avviamento	Starting motor cable	Cable moteur demarrage	Anlasser motor kabel	Cable motor de arranque	
	16	8000 91115	1	Teleruttore avviamento	Remote switch	Telerupteur	Fernshalter	Telerruptor	
	17	8SA0 67545	2	Vite	Screw	Vis	Schraube	Tornillo	
	18	8000 47472	1	Fusibile (15A)	Fuse (15A)	Fusible (15A)	Sicherung (15A)	Fusible (15A)	
<b>RW</b>	19	8000 A1882	1	Kit cablaggio RACING	RACING main wiring harness	Kit cables RACING	RACING Kabel Kit	Kit grupo cables RACING	
<b>RW</b>	20	8000 A1220	1	Cablaggio RACING	RACING wiring	Cables RACING	RACING Kabel	Cables RACING	
<b>RW</b>	21	8000 A0731	1	Pulsante arresto motore	Engine stop button	Poussoir arret moteur	Druckknopf Motoranhalten	Pùlsador parada motor	
<b>RW</b>	22	8000 A0732	1	Pulsante avviamento motore	Engine start button	Poussoir demarrage moteur	Motoranlassknopf	Pùlsador arranque motor	
<b>RW</b>	23	8000 94145	1	Pulsante avvisatore acustico	Horn button	Poussoir avertisseur acoustique	Hupe	Pùlsador avisador acustico	
<b>RW</b>	24	8000 93221	1	Interruttore luci	Lights switch	Poussoir feu	Lichtanzündung	Pùlsador luces	
<b>RW</b>	25	8000 71755	1	Cappuccio	Rubber cap	Capuchon	kappe	Capuchón	
	27	8000 88181	1	Elastico	Elastic	Elastique	Elastisch	Elástico	

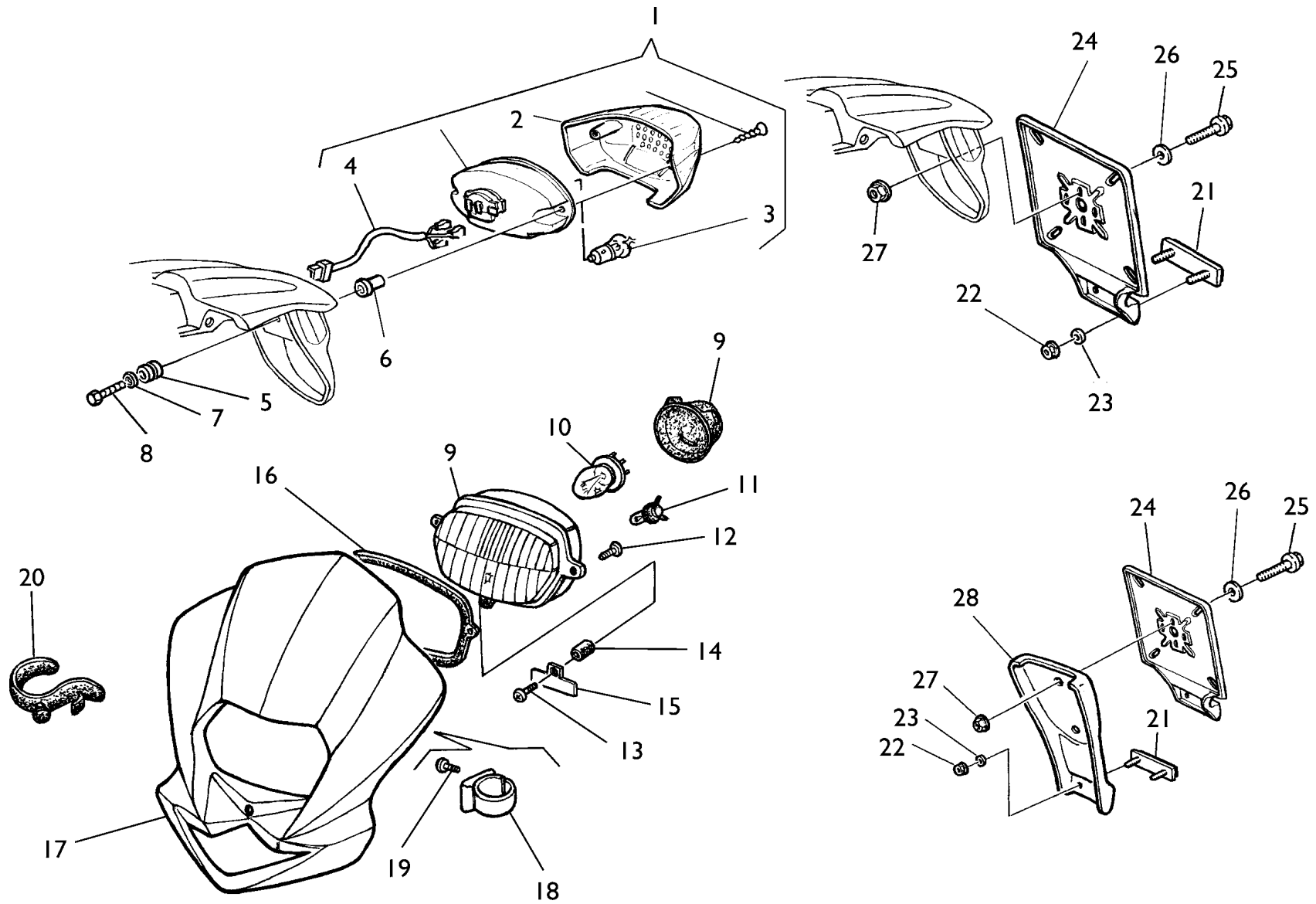





TE 250- 450,  
SM 400R-450R/ 2004

TAVOLA  
DRAWING  
TABLE  
BILD  
TABLA

33B

FANALI, PORTATARGA, PORTANUMERO - LIGHTS, PLATE HOLDER, NUMBER HOLDER - FEU, PORTE-BALAI,  
PORTE-NOMBRE - LAMPEN, SCHILDTRAEGER, NUMMERTRAGER - FANALES, PORTA-MATRICULA, PORTA  
NUMERO

Note Notes Markes Notas	Pos. No. N. Index Pos.	N. Cod. Code No. Nr. Code Code Nr N. Cod.	Q.tà Q.ty Q.te M.ge C.ad	DENOMINAZIONE	NAME	DESIGNATION	BESHREIBUNG	DENOMINACION	Validità Validity Validité Gültig Validez
X	1	8A00 88873	1	Fanale posteriore completo	Tail light	Feux arrière	Hinterleuchte	Faro trasero	
X	2	8A00 94119	1	Lente	Lens	Loupe	Linse	Lente	
X	3	8A00 18246	1	Lampada (12V-5/12 W)	Lamp (12V-5/12 W)	Lampe (12V-5/12 W)	Lampe (12V-5/12 W)	Lamparilla (12V-5/12 W)	
X	4	8000 94121	1	Cablaggio	Cable	Cable	Kabel	Cable	
X	5	8000 18048	2	Gommino	Rubber pad	Pièce caoutchouc	Gummstück	Junta de goma	
X	6	8A00 94120	2	Distanziale	Spacer	Entretoise	Distanzstück	Separador	
X	7	8A00 20373	2	Rosetta piana	Washer	Rondelle	Scheibe	Arandela	
X	8	8000 A0953	2	Vite	Screw	Vis	Schraube	Tornillo	
X	9	8000 A0278	1	Gruppo ottico	Optical group	Groupe optique	Optische Gruppe	Grupo óptico	
X	10	8000 20137	1	Lampada (12V-35/35 W)	Lamp (12V-35/35 W)	Lampe (12V-35/35 W)	Lampe (12V-35/35 W)	Lamparilla (12V-35/35 W)	
X	11	8000 26694	1	Lampada (12V-3 W)	Lamp (12V-3 W)	Lampe (12V-3 W)	Lampe (12V-3 W)	Lamparilla (12V-3 W)	
X	12	60N4 98033	2	Vite	Screw	Vis	Schraube	Tornillo	
X	13	8000 24962	1	Vite	Screw	Vis	Schraube	Tornillo	
X	14	8000 A1051	1	Distanziale	Spacer	Entretoise	Distanzstück	Separador	
X	15	8000 A1052	1	Piastrina	Plate	Plaque	Platte	Placa	
X	16	8000 A1053	1	Guarnizione	Gasket	Garniture	Dichtung	Junta	
WX	17	8000 A0233	1	Cupolino	Fairing	Carenage	Verkleidung	Cúpula	
MX	17	8000 A0233	1	Cupolino	Fairing	Carenage	Verkleidung	Cúpula	
				(codice colore E)	(color code E)	(code couleur E)	(Code Farbe E)	(código colòr E)	
MØX	17	80A0 A0233	1	Cupolino	Fairing	Carenage	Verkleidung	Cúpula	
				(codice colore G)	(color code G)	(code couleur G)	(Code Farbe G)	(código colòr G)	
X	18	8000 A0864	1	Anello	Ring	Bague	Ring	Anilo	
X	19	8A00 37283	2	Vite	Screw	Vis	Schraube	Tornillo	
X	20	8000 88602	4	Elastico	Elastic	Elastique	Elastisch	Elástico	
X	21	8000 73834	1	Catadiottro	Reflector	Catadioptrique	Ruckstrahler	Catafaros	
X	22	8000 40717	2	Dado	Nut	Ecrou	Mutter	Tuerca	
X	23	62N1 15547	2	Rosetta	Washer	Rondelle	Scheibe	Arandela	
X	24	8000 94595	1	Portatarga	Licence plate holder	Portebalai	Schildträger	Portamatricula	
X	25	8000 62727	2	Vite	Screw	Vis	Schraube	Tornillo	
X	26	8000 56359	2	Vite	Screw	Vis	Schraube	Tornillo	
X	27	8000 44240	2	Dado	Nut	Ecrou	Mutter	Tuerca	
RX	28	8000 94342	1	Paraspruzzi	Rear end	Terminal	Hinterkiff	Para rociada	

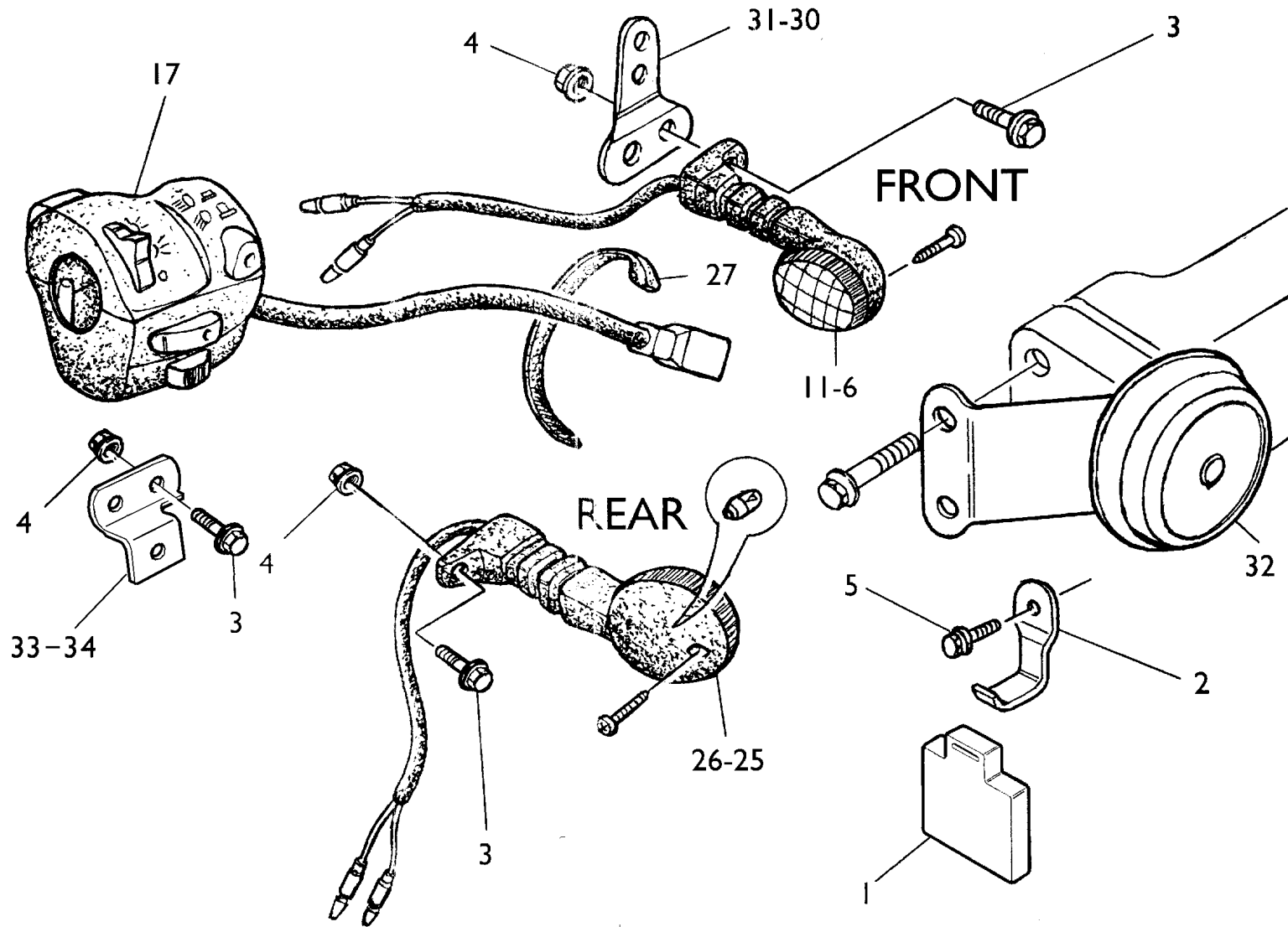



**TE 250- 450,  
SM 400R-450R/ 2004**

TAVOLA  
DRAWING  
TABLE  
BILD  
TABLA

**34**

**INDICATORI DI DIREZIONE, AVVISATORE ACUSTICO-BLINKERS, HORN-  
CLIGNOTANTS, SIGNAL ACOUSTIQUE-BLINKERS, HUPE-  
INTERMITENTES, AVISADOR ACUSTICO**

Note Notes Notes Marke Notas	Pos. No. N. Index Pos.	N. Cod. Code No. Nr. Code Code Nr N. Cod.	Q.tà Q.ty Q.te M.ge C.ad	DENOMINAZIONE	NAME	DESIGNATION	BESHREIBUNG	DENOMINACION	Validità Validity Validité Gültig Validez
<b>DX</b>	1	8000 A0645	1	Intermittenza	Flash device	Intermittence	Blinkgeber	Intermitencia	
<b>DX</b>	2	8000 A0678	1	Piastra per intermittenza	Plate (Flash device)	Plaque (Intermittence)	Platte (Blinkgeber)	Placa (Intermitencia)	
<b>DX</b>	3	8000 62727	4	Vite (M6x16 mm)	Screw (M6x16 mm)	Vis (M6x16 mm)	Schraube (M6x16 mm)	Tornillo (M6x16 mm)	
<b>DX</b>	4	8000 44240	4	Dado	Nut	Ecrou	Mutter	Tuerca	
<b>DX</b>	5	8000 67997	1	Vite	Screw	Vis	Schraube	Tornillo	
<b>DX</b>	6	8000 A0227	1	Indicatore anteriore DX	R.H. Blinker	Clignotant D.	R. Blinker	Intermitente D.	
<b>DX</b>	11	8000 A0228	1	Indicatore anteriore SX	L.H. Blinker	Clignotant G.	L. Blinker	Intermitente I.	
<b>X</b>	17	8000 99625	1	Commutatore SX compl.	L.H. Switch compl.	Commutateur G. compl.	L. Kombischalter kpl.	Conmutador I. compl.	
	17	8000 99721	1	Commutatore SX compl. ( J )	L.H. Switch compl. ( J )	Commutateur G. compl. ( J )	L. Kombischalter kpl. ( J )	Conmutador I. compl. ( J )	
<b>DX</b>	25	8000 A0229	1	Indicatore posteriore DX	R.H. Blinker	Clignotant D	Blinker R	Intermitente D	
<b>DX</b>	26	8000 A0230	1	Indicatore posteriore SX	L.H. Blinker	Clignotant G	Blinker L	Intermitente I	
	27	8000 71578	2	Fascetta	Clamp	Collier	Schelle	Banda	
<b>DX</b>	30	8000 93011	1	Piastrina DX	R.H. Plate	Plaque D.	R. Platte	Placa D.	
<b>DX</b>	31	8A00 93011	1	Piastrina SX	L.H. Plate	Plaque G.	L. Platte	Placa I.	
<b>DX</b>	32	8000 A1048	1	Avvisatore acustico	Horn	Signal acoustique	Hupe	Avisador acustico	
<b>DX</b>	33	8000 A2044	1	Piastrina posteriore DX	R.H. rear plate	Plaque arriere D.	R. Hint. Platte	Placa trasera D.	
<b>DX</b>	34	8A00 A2044	1	Piastrina posteriore SX	L.H. rear plate	Plaque arriere G.	L Hint. Platte	Placa trasera I.	

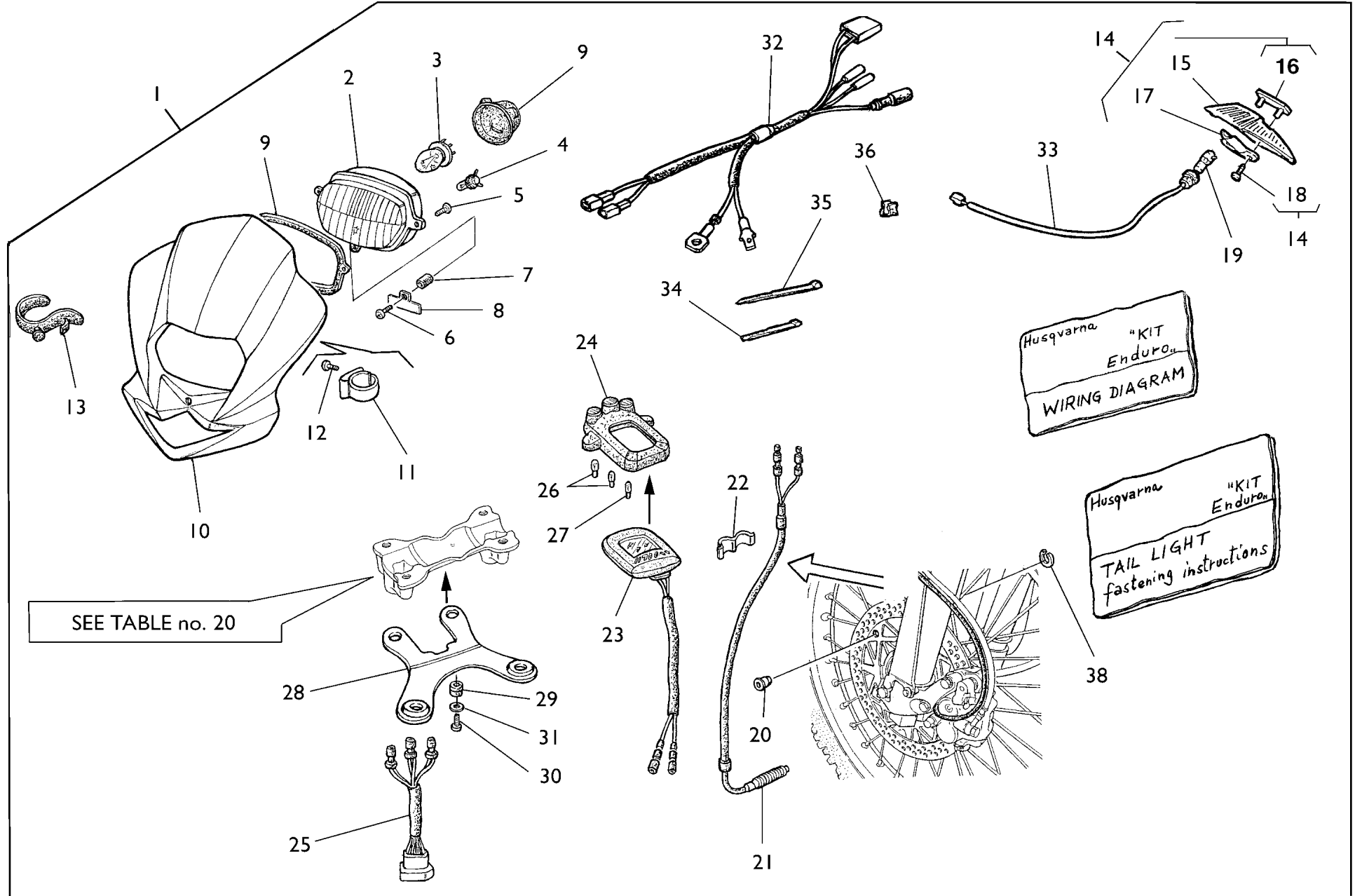



TE 250-450 USA,  
SM 450R USA/2004

TAVOLA  
DRAWING  
TABLE  
BILD  
TABLA

35

KIT "Enduro" - "Enduro" KIT - GROUPE "Enduro"  
"Enduro" GRUPE - KIT "Enduro"

Note Notes Notas	Pos. No. Index	N. Cod. Code No. Nr. Code Code Nr N. Cod.	Q.tà Q.ty M.ge C.ad	DENOMINAZIONE	NAME	DESIGNATION	BESHREIBUNG	DENOMINACION	Validità Validity Validité Gültig Validez
<b>WC</b>	1	8000 A0396	1	Kit ENDURO	ENDURO Kit	Groupe ENDURO	Gruppe ENDURO	Kit ENDURO	
<b>DM</b>	1	8000 A3122	1	Kit ENDURO	ENDURO Kit	Groupe ENDURO	Gruppe ENDURO	Kit ENDURO	
	2	8000 A0278	1	Gruppo ottico	Optical group	Groupe optique	Optische Gruppe	Grupo óptico	
	3	8000 20137	1	Lampada (12V-35/35 W)	Lamp (12V-35/35 W)	Lampe (12V-35/35 W)	Lampe (12V-35/35 W)	Lamparilla (12V-35/35 W)	
	4	8000 26694	2	Lampadina (12V-3 W)	Lamp (12V-3 W)	Lampe (12V-3 W)	Lampe (12V-3 W)	Lamparilla (12V-3 W)	
	5	60N4 98033	2	Vite	Screw	Vis	Schraube	Tornillo	
	6	60N4 24962	1	Vite	Screw	Vis	Schraube	Tornillo	
	7	8000 A1051	1	Distanziale	Spacer	Entretoise	Distanzstück	Separador	
	8	8000 A1052	1	Piastrina	Plate	Plaque	Platte	Placa	
	9	8000 A1053	1	Guarnizione	Gasket	Garniture	Dichtung	Junta	
<b>WC</b>	10	8000 A0233	1	Cupolino con decalcomanie	Fairing with decals	Carenage avec decalc.	Verkleidung mit abziehbild	Cúpula con calcomanias	
<b>M</b>	10	8000 A0233	1	Cupolino con decalcomanie (codice colore E)	Fairing with decals (color code E)	Carenage avec decalc. (code couleur E)	Verkleidung mit abziehbild (Code Farbe E)	Cúpula con calcomanias (còdigo colòr E)	
<b>M</b>	10	80A0 A0233	1	Cupolino con decalcomanie (codice colore G)	Fairing with decals (color code G)	Carenage avec decalc. (code couleur G)	Verkleidung mit abziehbild (Code Farbe G)	Cúpula con calcomanias (còdigo colòr G)	
	11	8000 A0864	1	Anello	Ring	Bague	Ring	Anilo	
	12	8A00 37283	2	Vite	Screw	Vis	Schraube	Tornillo	
	13	8000 88602	4	Elastico	Elastic	Elastique	Elastisch	Elástico	
	14	8000 71213	1	Fanale posteriore completo	Tail light group	Groupe feux arrière	Hinterleuchte Gruppe	Grupo faro trasero	
	15	8000 71214	1	Fanale posteriore	Tail light	Feux arrière	Hinterleuchte	Faro trasero	
	16	8000 71215	1	Fascetta	Clamp	Collier	Schelle	Banda	
	17	8000 71216	1	Protezione	Guard	Protection	Schutz	Protección	
	18	8000 71217	2	Vite	Screw	Vis	Schraube	Tornillo	
	19	8000 26694	2	Lampadina (12V-3 W)	Lamp (12V-3 W)	Lampe (12V-3 W)	Lampe (12V-3 W)	Lamparilla (12V-3 W)	
	20	8000 99775	1	Magnete	Magnet	Amiant	Magnet	Imán	
	21	8000 99652	1	Sensore magnetico	Sensor	Palpeur	Sensor	Sensor	
	22	8000 A0664	2	Molletta	Clip	Collier	Schelle	Banda	
	23	8000 99650	1	Contachilometri digitale	Digital speedometer	Compteur-km digital	Digital Tachometer	Cuenta-kilómetros digital	
	24	8000 A0883	1	Supporto spie	Holder	Support	Halterung	Soporte	
	25	8000 99651	1	Gruppo cavi	Cable assy	Cables compl.	Kabel Kpl.	Grupo cables	
	26	8000 20602	2	Lampadina (12V-1,2 W)	Lamp (12V-1,2 W)	Lampe (12V-1,2 W)	Lampe (12V-1,2 W)	Lamparilla (12V-1,2 W)	
	27	8000 60033	2	Lampadina (12V-2 W)	Lamp (12V-2 W)	Lampe (12V-2 W)	Lampe (12V-2 W)	Lamparilla (12V-2 W)	
	28	80A0 99774	1	Piastra	Plate	Plaque	Platte	Placa	

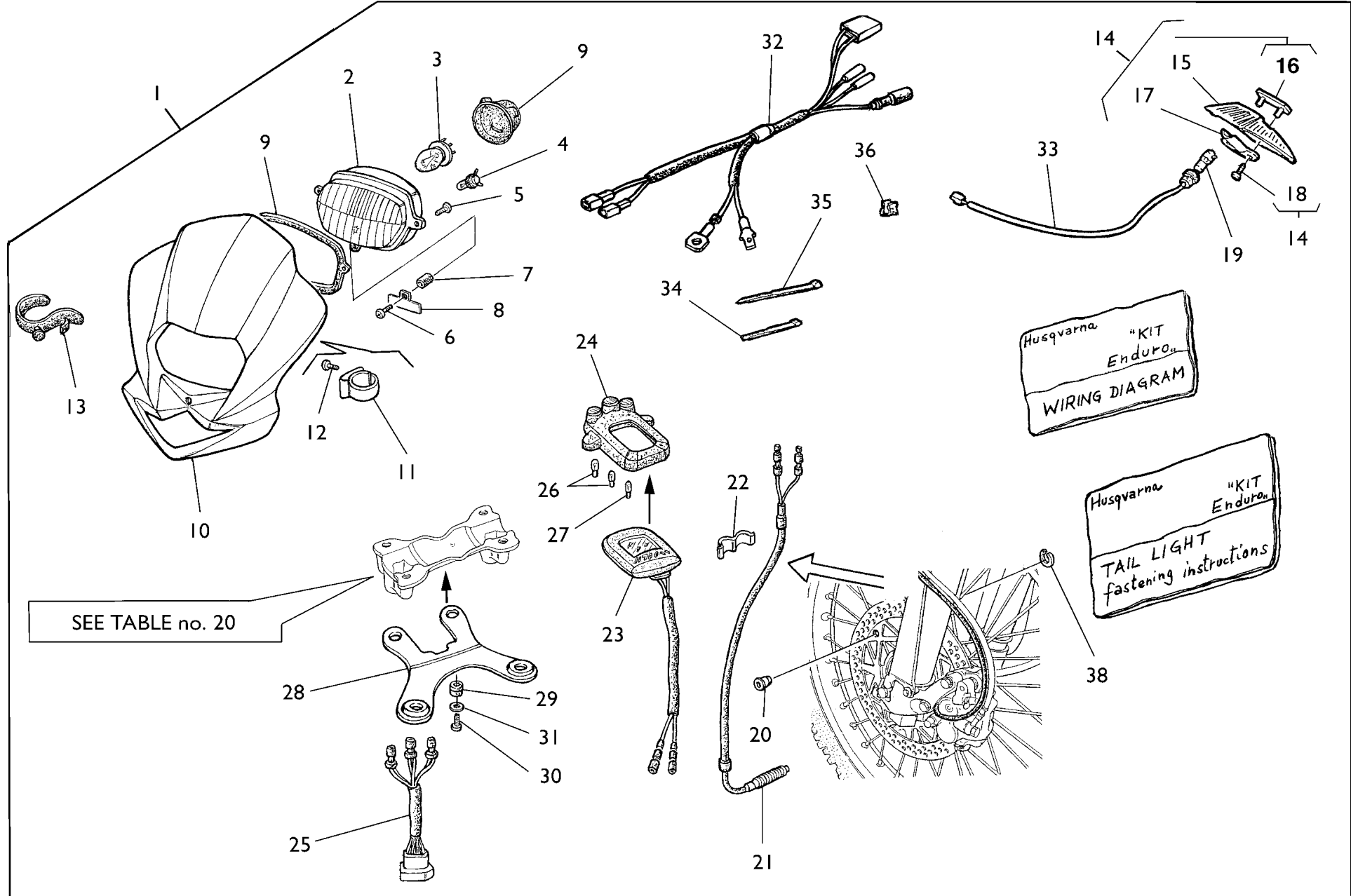





TE 250-450 USA,  
SM 450R USA/2004

TAVOLA  
DRAWING  
TABLE  
BILD  
TABLA

35

KIT "Enduro" - "Enduro" KIT - GROUPE "Enduro"  
"Enduro" GRUPPE - KIT "Enduro"

Note Notes Markes Notas	Pos. No. N. Index Pos.	N. Cod. Code No. Nr. Code Code Nr N. Cod.	Q.tà Q.ty Q.té M.ge C.ad	DENOMINAZIONE	NAME	DESIGNATION	BESHREIBUNG	DENOMINACION	Validità Validity Validité Gültig Validez
	29	8000 41862	2	Passacavo	Fairlead	Passe-câble	Kabelführung	Prensa-cable	
	30	8000 89069	2	Vite	Screw	Vis	Schraube	Tornillo	
	31	62N4 15548	2	Rosetta	Washer	Rondelle	Scheibe	Arandela	
	32	8000 91983	1	Gruppo cavi (ANTERIORE)	Cable assy (FRONT)	Cables compl. (AVANT)	Kabel Kpl. (VORDERE)	Grupo cables (DELANTERO)	
	33	8000 71221	1	Gruppo cavi (POSTERIORE)	Cable assy (REAR)	Cables compl. (ARRIERE)	Kabel Kpl. (HINTERE)	Grupo cables (TRASERO)	
	34	8000 56444	3	Fascetta (L=188mm)	Clamp (L=188mm)	Collier (L=188mm)	Schelle (L=188mm)	Banda (L=188mm)	
	35	8000 34002	2	Fascetta (L=240mm)	Clamp (L=240mm)	Collier (L=240mm)	Schelle (L=240mm)	Banda (L=240mm)	
	36	8000 72494	2	Molletta	Clip	Collier	Schelle	Banda	
	38	66N0 21200	1	Anello elastico	Snap ring	Bague d'arret	Haltering	Anillo elástico	



Note Notes Marka Notas	Pos. No. N. Index Pos.	N. Cod. Code No. Nr. Code Code Nr N. Cod.	Q.tà Q.ty Q.te M.ge C.ad	DENOMINAZIONE	NAME	DESIGNATION	BESHREIBUNG	DENOMINACION	Validità Validity Validité Gültig Validez
	2	8000 A3195	1	Decal per parafango anteriore	Transfer	Decalcomania	Abziehbild	Calcomania	
	3	8000 A3196	1	Decal per portafaro	L.H. transfer	Decalcomania G.	Abziehbild L.	Calcomania izq.	
	4	8000 A2782	1	Decal per convogliatore Dx	R.H. transfer	Decalcomania D.	Abziehbild R.	Calcomania der.	
	5	8000 A2783	1	Decal per convogliatore Sx	L.H. transfer	Decalcomania G.	Abziehbild L.	Calcomania izq.	
	6	8000 A2778	1	Decal per fianchetto sup. Dx	R.H. upper transfer	Decalcomania sup. D.	Unterabziehbild R.	Calcomania sup. der.	
	7	8000 A2777	1	Decal per fianchetto sup. Sx	L.H. upper transfer	Decalcomania sup. G.	Unterabziehbild L.	Calcomania sup. izq.	
	8	8000 A2842	2	Decal per forcellone (TE 250)	Fork transfer	Decalcomania	Abziehbild	Calcomania	
	8	8000 A2851	2	Decal per forcellone (TE 450)	Fork transfer	Decalcomania	Abziehbild	Calcomania	
	9	8000 A2122	1	Decal parafango posteriore	Transfer	Decalcomania	Abziehbild	Calcomania	
	10	8000 A3114	1	Decal per fianchetto inf. Dx	R.H. lower transfer	Decalcomania inf. D.	Oberabziehbild R.	Calcomania inf. der.	
	11	8000 A3113	1	Decal per fianchetto inf. Sx	L.H. lower transfer	Decalcomania inf. G.	Oberabziehbild L.	Calcomania inf. izq.	



Note Notes Marka Notas	Pos. No. N. Index Pos.	N. Cod. Code No. Nr. Code Code Nr N. Cod.	Q.tà Q.ty Q.te M.ge C.ad	DENOMINAZIONE	NAME	DESIGNATION	BESHREIBUNG	DENOMINACION	Validità Validity Validité Gültig Validez
	2	8000 A3195	1	Decal per parafango anteriore	Transfer	Decalcomania	Abziehbild	Calcomania	
	3	8000 A3196	1	Decal per portanumero	L.H. transfer	Decalcomania G.	Abziehbild L.	Calcomania izq.	
	4	8000 A2782	1	Decal per convogliatore Dx	R.H. transfer	Decalcomania D.	Abziehbild R.	Calcomania der.	
	5	8000 A2783	1	Decal per convogliatore Sx	L.H. transfer	Decalcomania G.	Abziehbild L.	Calcomania izq.	
	6	8000 A2778	1	Decal per fianchetto sup. Dx	R.H. upper transfer	Decalcomania sup. D.	Unterabziehbild R.	Calcomania sup. der.	
	7	8000 A2777	1	Decal per fianchetto sup. Sx	L.H. upper transfer	Decalcomania sup. G.	Unterabziehbild L.	Calcomania sup. izq.	
	8	8000 A2861	2	Decal per forcellone (TC 250)	Fork transfer	Decalcomania	Abziehbild	Calcomania	
	8	8000 A2870	2	Decal per forcellone (TC 450)	Fork transfer	Decalcomania	Abziehbild	Calcomania	
	8	8000 A2842	2	Decal per forcellone (TE 250 USA)	Fork transfer	Decalcomania	Abziehbild	Calcomania	
	8	8000 A2851	2	Decal per forcellone (TE 450 USA)	Fork transfer	Decalcomania	Abziehbild	Calcomania	
	9	8000 A3113	1	Decal per fianchetto inf. Sx	L.H. lower transfer	Decalcomania inf. G.	Oberabziehbild L.	Calcomania inf. izq.	
	10	8000 A3114	1	Decal per fianchetto inf. Dx	R.H. lower transfer	Decalcomania inf. D.	Oberabziehbild R.	Calcomania inf. der.	
	11	8000 A2122	1	Decal parafango posteriore	Transfer	Decalcomania	Abziehbild	Calcomania	
	12	8000 A3198	1	Decal per parastelo Dx	R.H. transfer	Decalcomania D.	Abziehbild R.	Calcomania der.	
	13	8000 A3197	1	Decal per parastelo Sx	L.H. transfer	Decalcomania G.	Abziehbild L.	Calcomania izq.	





Note Notes Marke Notas	Pos. No. N. Index Pos.	N. Cod. Code No. Nr. Code Code Nr N. Cod.	Q.tà Q.ty M.ge C.ad	DENOMINAZIONE	NAME	DESIGNATION	BESHREIBUNG	DENOMINACION	Validità Validity Validité Gültig Validez
	2	8000 A3195	1	Decal per parafango anteriore	Transfer	Decalcomania	Abziehbild	Calcomania	
	3	8000 A3196	1	Decal per portanumero	L.H. transfer	Decalcomania G.	Abziehbild L.	Calcomania izq.	
	4	8000 A2783	1	Decal Sx per serbatoio	L.H. transfer	Decalcomania G.	Abziehbild L.	Calcomania izq.	
	5	8000 A2782	1	Decal Dx per serbatoio	R.H. transfer	Decalcomania D.	Abziehbild R.	Calcomania der.	
	6	8000 A2778	1	Decal per fianchetto sup. Dx	R.H. upper transfer	Decalcomania sup. D.	Unterabziehbild R.	Calcomania sup. der.	
	7	8000 A2777	1	Decal per fianchetto sup. Sx	L.H. upper transfer	Decalcomania sup. G.	Unterabziehbild L.	Calcomania sup. izq.	
	8	8000 A3114	1	Decal per fianchetto inf. Dx	R.H. lower transfer	Decalcomania inf. D.	Oberabziehbild R.	Calcomania inf. der.	
	9	8000 A3113	1	Decal per fianchetto inf. Sx	L.H. lower transfer	Decalcomania inf. G.	Oberabziehbild L.	Calcomania inf. izq.	
	10	8000 A2122	1	Decal per parafango post.	Transfer	Decalcomania	Abziehbild	Calcomania	
	11	8000 A3088	2	Decal per forcellone (400)	Fork transfer (400)	Decalcomania (400)	Abziehbild (400)	Calcomania (400)	
	11	8000 A3327	2	Decal per forcellone (450)	Fork transfer (450)	Decalcomania (450)	Abziehbild (450)	Calcomania (450)	
	12	8000 A3198	1	Decal per parastelo Dx	R.H. transfer	Decalcomania D.	Abziehbild R.	Calcomania der.	
	13	8000 A3197	1	Decal per parastelo Sx	L.H. transfer	Decalcomania G.	Abziehbild L.	Calcomania izq.	





**SM 450 R/ 2004**  
**BLACK**

TAVOLA  
DRAWING  
TABLE  
BILD  
TABLA

**39**

**DECALCOMANIE (codice colore G) - TRANSFER (color code G)**  
**DACALCOMANIE (code couleur G) - ABZIEHBILD (Code Farbe G)**  
**CALCOMANIA (còdigo colòr G)**

Note Notes Marke Notas	Pos. No. N. Index Pos.	N. Cod. Code No. Nr. Code Code Nr N. Cod.	Q.tà Q.ty Q.te M.ge C.ad	DENOMINAZIONE	NAME	DESIGNATION	BESHREIBUNG	DENOMINACION	Validità Validity Validité Gültig Validez
	2	8000 A0638	1	Decal per parafango anteriore	TransferTC	Decalcomania	Abziehbild	Calcomania	
	3	8000 A3201	1	Decal per portanumero	L.H. transfer	Decalcomania G.	Abziehbild L.	Calcomania izq.	
	3	80A0 97857	1	Decal per portafaro (USA)	L.H. transfer (USA)	Decalcomania G. (USA)	Abziehbild L. (USA)	Calcomania izq. (USA)	
	4	8000 A0725	1	Decal Sx per serbatoio	L.H. transfer	Decalcomania G.	Abziehbild L.	Calcomania izq.	
	5	8000 A0724	1	Decal Dx per serbatoio	R.H. transfer	Decalcomania D.	Abziehbild R.	Calcomania der.	
	6	8000 A1627	1	Decal per fianchetto Sx	L.H. transfer	Decalcomania G.	Abziehbild L.	Calcomania izq.	
	7	8000 A1626	1	Decal per fianchetto Dx	R.H. transfer	Decalcomania D.	Abziehbild R.	Calcomania der.	
	8	8000 A3713	1	Decal per fianchetto Sx	L.H. transfer	Decalcomania G.	Abziehbild L.	Calcomania izq.	
	9	8000 A3714	1	Decal per fianchetto Dx	R.H. transfer	Decalcomania D.	Abziehbild R.	Calcomania der.	
	10	8000 A2122	1	Decal per parafango post.	Transfer	Decalcomania	Abziehbild	Calcomania	
	11	8000 A3327	2	Decal per forcellone	Fork transfer	Decalcomania	Abziehbild	Calcomania	
	12	80A0 A3198	1	Decal per parastelo Dx	R.H. transfer	Decalcomania D.	Abziehbild R.	Calcomania der.	
	13	80A0 A3197	1	Decal per parastelo Sx	L.H. transfer	Decalcomania G.	Abziehbild L.	Calcomania izq.	

DISEGNO DRAWING DESSIN ZEICHNUNG DIBUJO	TAVOLA DRAWING TABLE BILD TABLA	INDEX NO. POS. N. INDICE	DISEGNO DRAWING DESSIN ZEICHNUNG DIBUJO	TAVOLA DRAWING TABLE BILD TABLA	INDEX NO. POS. N. INDICE	DISEGNO DRAWING DESSIN ZEICHNUNG DIBUJO	TAVOLA DRAWING TABLE BILD TABLA	INDEX NO. POS. N. INDICE	DISEGNO DRAWING DESSIN ZEICHNUNG DIBUJO	TAVOLA DRAWING TABLE BILD TABLA	INDEX NO. POS. N. INDICE	DISEGNO DRAWING DESSIN ZEICHNUNG DIBUJO	TAVOLA DRAWING TABLE BILD TABLA	INDEX NO. POS. N. INDICE	DISEGNO DRAWING DESSIN ZEICHNUNG DIBUJO	TAVOLA DRAWING TABLE BILD TABLA	INDEX NO. POS. N. INDICE
1511	33302	23 16	64N1	20048	19 50	8000	20602	35 26	8000	36467	27 26	8000	43928	21 37	8000	55878	31 15
1513	07001	19 25	64N1	20068	19 12	8000	21375	12 15	8000	36653	15 50	8000	43928	21 44	8000	55902	25 4
1513	41401	28 12	64N1	20068	25 7	8000	21480	25 25	8000	36786	12 32	8000	43928	31 18	8000	55903	25 13
1513	71301	14 10	66N0	21197	32 13	8000	21480	29 24	8000	36856	6 3	8000	44240	21 33	8000	56359	33B 26
1513	74301	28 21	66N0	21200	32 13	8000	21480	29A 22	8000	36857	6 4	8000	44240	21 46	8000	56377	25 6
1514	03203	28 11	66N0	21200	35 38	8000	22373	16 21	8000	37140	17 33	8000	44240	28 16	8000	56381	27 4
1515	50601	21 32	66N0	21202	12 19	8000	22373	16A 21	8000	37745	27 10	8000	44240	33B 27	8000	56443	20 72
1517	94702	1 1	66N0	21205	7 18	8000	22551	25 3	8000	38287	15 46	8000	44240	34 4	8000	56444	33 3
1519	84701	1 13	66N0	21206	16A 64	8000	22966	30 23	8000	38520	16 29	8000	44298	4 45	8000	56444	33A 3
1610	77601	8 16	66N0	21208	15 13	8000	22966	30A 23	8000	38520	16A 29	8000	45042	28 18	8000	56444	35 34
1610	77703	8 14	66N0	21211	16 16	8000	23107	4 46	8000	38521	23 9	8000	45194	4 42	8000	56462	17 17
1610	77703	9 16	66N0	21211	16 26	8000	23107	12 34	8000	38711	16 35	8000	45495	21 35	8000	56767	31 28
1614	59002	8 17	66N0	21211	16A 16	8000	23374	4 31	8000	38711	16A 35	8000	45495	26 33	8000	56768	31 27
1615	09801	7 19	66N0	21211	16A 26	8000	24952	9 5	8000	38712	16 36	8000	45495	27 27	8000	56783	33 4
1615	35501	3 5	66N0	21257	3 5	8000	24962	33B 13	8000	38712	16A 36	8000	46664	29A 3	8000	56783	33A 4
1615	35801	3 12	66N0	21258	10 4	8000	25082	12 8	8000	38728	16A 63	8000	46893	19 57	8000	56920	1 21
1615	35902	4 41	66N0	21270	30 22	8000	26694	33B 11	8000	38748	27 31	8000	46893	19 63	8000	57155	25 24
1615	38801	6 19	66N0	21270	30A 22	8000	26694	35 4	8000	38767	23 15	8000	46893	26 5	8000	57155	25 26
1617	95501	4 4	66N0	21272	31 24	8000	26694	35 19	8000	40007	17 11	8000	46893	28 17	8000	57155	29 23
1617	95501	17 5	66N0	21312	9 13	8000	26884	12 22	8000	40717	33B 22	8000	47472	33 18	8000	57155	29A 21
1617	95502	12 10	69N4	29004	30A 9	8000	27122	17 7	8000	40718	18 8	8000	47472	33A 18	8000	57196	5 3
60N1	01059	21 60	69N4	29005	31 7	8000	28929	27 30	8000	40796	31 17	8000	47708	4 32	8000	57196	5 4
60N1	01140	19 59	6BN0	21506	15 47	8000	29171	12 33	8000	41459	19 48	8000	47763	4 18	8000	57196	16 14
60N1	01219	20 62	8000	01199	27 6	8000	31772	16 6	8000	41693	16 24	8000	47773	12 13	8000	57196	16A 14
60N1	02483	14 9	8000	01412	23 19	8000	31772	16A 6	8000	41693	16A 24	8000	48802	26 2	8000	58207	33 5
60N1	02488	14 7	8000	01688	31 3	8000	32388	21 56	8000	41862	32 10	8000	48814	26 23	8000	58207	33A 5
60N1	02510	6 9	8000	05876	15 32	8000	33288	29A 9	8000	41862	35 29	8000	49035	31 4	8000	59289	21 24
60N1	02510	27 18	8000	07719	10 12	8000	33373	19 20	8000	42022	22 31	8000	49036	30 4	8000	59801	17 22
60N1	07701	29A 17	8000	07719	11 5	8000	33718	12 17	8000	42022	23 26	8000	49654	29 16	8000	59802	17 20
60N3	02463	13 3	8000	08536	21 55	8000	34002	35 35	8000	42023	23 12	8000	49792	4 2	8000	59803	17 19
60N4	24962	35 6	8000	10777	31 3	8000	34317	4 21	8000	42023	23 18	8000	50005	24 8	8000	59977	8 13
60N4	98033	33B 12	8000	13346	30 3	8000	34317	6 11	8000	42278	17 2	8000	50453	17 31	8000	60033	32 8
60N4	98033	35 5	8000	17040	9 8	8000	34317	7 2	8000	42345	29A 4	8000	51746	8 7	8000	60033	35 27
61N1	15501	29A 18	8000	17810	21 21	8000	34317	7 7	8000	42349	25 21	8000	51746	9 18	8000	60233	20 59
62N0	15678	12 29	8000	18048	33B 5	8000	34317	7 11	8000	42676	16 54	8000	53155	20 61	8000	60234	20 60
62N0	15679	12 31	8000	18921	29A 14	8000	34317	17 9	8000	42676	16A 54	8000	53259	25 29	8000	60577	15 48
62N1	15504	19 49	8000	19965	4 39	8000	34451	8 11	8000	42677	16 55	8000	53259	25 33	8000	60873	27 32
62N1	15538	19 64	8000	20137	33B 10	8000	34609	12 23	8000	42677	16A 55	8000	53259	29 20	8000	60898	19 4
62N1	15547	33B 23	8000	20137	35 3	8000	35531	19 34	8000	43391	19 29	8000	53339	17 10	8000	61078	25 14
62N1	15549	18 10	8000	20536	21 14	8000	35763	15 28	8000	43567	8 6	8000	54073	31 4	8000	61275	7 20
62N4	15548	32 12	8000	20536	21 61	8000	36137	21 40	8000	43592	27 5	8000	54700	4 27	8000	61313	26 4
62N4	15548	35 31	8000	20602	32 7	8000	36380	15 45	8000	43928	19 31	8000	55772	29A 16	8000	61314	20 63

DISEGNO DRAWING DESSIN ZEICHNUNG DIBUJO	TAVOLA DRAWING TABLE BILD TABLA	INDEX NO. POS. N. INDICE	DISEGNO DRAWING DESSIN ZEICHNUNG DIBUJO	TAVOLA DRAWING TABLE BILD TABLA	INDEX NO. POS. N. INDICE	DISEGNO DRAWING DESSIN ZEICHNUNG DIBUJO	TAVOLA DRAWING TABLE BILD TABLA	INDEX NO. POS. N. INDICE	DISEGNO DRAWING DESSIN ZEICHNUNG DIBUJO	TAVOLA DRAWING TABLE BILD TABLA	INDEX NO. POS. N. INDICE	DISEGNO DRAWING DESSIN ZEICHNUNG DIBUJO	TAVOLA DRAWING TABLE BILD TABLA	INDEX NO. POS. N. INDICE	DISEGNO DRAWING DESSIN ZEICHNUNG DIBUJO	TAVOLA DRAWING TABLE BILD TABLA	INDEX NO. POS. N. INDICE
8000 61355	20	53	8000 62729	10	7	8000 66181	29A	7	8000 71009	16A	40	8000 73500	9	15	8000 86136	23	8
8000 62705	33	12	8000 62729	10	15	8000 66525	8	19	8000 71010	16	34	8000 73832	20	82	8000 86136	23	21
8000 62705	33A	12	8000 62729	11	4	8000 66525	12	24	8000 71010	16	41	8000 73834	33B	21	8000 86137	23	22
8000 62725	7	13	8000 62729	15	2	8000 66525	16	56	8000 71010	16A	34	8000 73894	25	1	8000 86140	23	7
8000 62725	8	30	8000 62729	20	40	8000 66525	16A	56	8000 71010	16A	41	8000 74016	21	38	8000 86176	23	3
8000 62725	21	47	8000 62729	29	37	8000 66651	19	47	8000 71213	35	14	8000 74836	4	6	8000 86176	23	20
8000 62725	25	18	8000 62729	29A	15	8000 66652	19	45	8000 71214	35	15	8000 75160	21	51	8000 86177	23	24
8000 62725	29A	12	8000 62730	4	28	8000 66774	8	23	8000 71215	35	16	8000 75166	21	39	8000 86177	23	25
8000 62726	16	43	8000 62730	17	6	8000 66802	1	7	8000 71216	35	17	8000 76283	21	11	8000 86732	15	5
8000 62726	16	48	8000 62730	19	62	8000 66973	8	26	8000 71217	35	18	8000 76338	25	10	8000 86878	10	14
8000 62726	16A	43	8000 62731	8	24	8000 67744	3	11	8000 71221	35	33	8000 76687	24	3	8000 86951	17	35
8000 62726	16A	48	8000 62731	21	29	8000 67997	20	68	8000 71445	25	27	8000 76688	24	2	8000 86953	16	25
8000 62726	18	9	8000 62731	21	45	8000 67997	21	14	8000 71445	29	14	8000 77373	20	20	8000 86953	16A	25
8000 62726	22	24	8000 62731	28	15	8000 67997	21	57	8000 71445	29A	32	8000 79015	1	11	8000 87243	19	25
8000 62726	26	27	8000 62732	19	51	8000 67997	34	5	8000 71578	24	26	8000 79065	29	21	8000 87299	16	37
8000 62726	26	32	8000 62733	29	12	8000 68490	29A	8	8000 71578	34	27	8000 79066	25	22	8000 87299	16A	37
8000 62726	28	13	8000 62795	21	36	8000 69056	19	3	8000 71620	21	13	8000 79066	29	22	8000 87736	20	56
8000 62726	31	15	8000 62795	21	43	8000 69111	19	21	8000 71621	21	53	8000 79072	25	16	8000 87745	20	73
8000 62727	3	13	8000 62796	19	19	8000 69125	25	2	8000 71622	21	2	8000 79075	25	28	8000 87810	21	10
8000 62727	14	5	8000 62796	20	2	8000 69148	26	15	8000 71623	21	19	8000 79077	17	32	8000 88181	33	27
8000 62727	14	14	8000 63312	19	39	8000 69149	26	7	8000 71755	33A	25	8000 79099	29	7	8000 88181	33A	27
8000 62727	15	11	8000 63312	21	54	8000 69150	19	18	8000 71806	29	10	8000 79789	31	28	8000 88231	22	21
8000 62727	24	19	8000 63821	16	9	8000 69282	20	69	8000 71806	29A	34	8000 79790	31	28	8000 88244	16A	3
8000 62727	25	12	8000 63822	16	4	8000 69282	21	52	8000 72022	29	13	8000 80171	13	6	8000 88245	16A	7
8000 62727	26	14	8000 63822	16A	4	8000 69315	20	57	8000 72168	23	14	8000 80171	13	6	8000 88246	16A	8
8000 62727	27	28	8000 63827	16	62	8000 69429	18	5	8000 72425	12	21	8000 80260	20	54	8000 88247	16A	11
8000 62727	28	14	8000 63827	16A	62	8000 69429	22	23	8000 72426	12	20	8000 81508	6	6	8000 88251	16A	15
8000 62727	33B	25	8000 63828	16	62	8000 69429	26	17	8000 72427	12	7	8000 81519	6	8	8000 88252	16A	66
8000 62727	34	3	8000 63828	16A	62	8000 69429	26	21	8000 72494	26	37	8000 81628	21	63	8000 88253	16A	18
8000 62728	4	38	8000 63829	16	62	8000 69429	26	22	8000 72494	33A	6	8000 81675	12	25	8000 88254	16A	17
8000 62728	10	15	8000 63829	16A	62	8000 69429	27	29	8000 72494	35	36	8000 82948	12	2	8000 88255	16	10
8000 62728	10	18	8000 63830	16	62	8000 69549	18	2	8000 72641	18	3	8000 83395	20	3	8000 88255	16A	65
8000 62728	12	11	8000 63830	16A	62	8000 70024	18	7	8000 72826	16	51	8000 84938	30	13	8000 88256	16A	19
8000 62728	14	7	8000 63831	16	62	8000 70216	16	59	8000 72826	16A	51	8000 84938	30A	13	8000 88257	16A	20
8000 62728	14	14	8000 63831	16A	62	8000 70216	16A	59	8000 72868	21	42	8000 85395	9	11	8000 88280	24	1
8000 62728	16	61	8000 63885	3	2	8000 70277	33A	2	8000 72869	21	41	8000 85493	16	47	8000 88602	33B	20
8000 62728	16A	61	8000 65411	21	31	8000 70696	25	5	8000 72873	21	5	8000 85493	16A	47	8000 88602	35	13
8000 62728	17	21	8000 65412	21	9	8000 71007	16	38	8000 72874	21	28	8000 85495	16	44	8000 88887	31	14
8000 62728	18	13	8000 65437	24	21	8000 71007	16A	38	8000 72875	21	27	8000 85495	16A	44	8000 89069	32	11
8000 62728	24	17	8000 65442	31	27	8000 71008	16	39	8000 73011	12	30	8000 85932	25	30	8000 89069	35	30
8000 62728	26	11	8000 65464	31	28	8000 71008	16A	39	8000 73140	19	5	8000 86107	16	46	8000 89089	22	11
8000 62728	26	18	8000 65884	8	10	8000 71009	16	40	8000 73500	8	15	8000 86107	16A	46	8000 89572	31	26

DISEGNO DRAWING DESSIN ZEICHNUNG DIBUJO	TAVOLA DRAWING TABLE BILD TABLA	INDEX NO. POS. N. INDICE	DISEGNO DRAWING DESSIN ZEICHNUNG DIBUJO	TAVOLA DRAWING TABLE BILD TABLA	INDEX NO. POS. N. INDICE	DISEGNO DRAWING DESSIN ZEICHNUNG DIBUJO	TAVOLA DRAWING TABLE BILD TABLA	INDEX NO. POS. N. INDICE	DISEGNO DRAWING DESSIN ZEICHNUNG DIBUJO	TAVOLA DRAWING TABLE BILD TABLA	INDEX NO. POS. N. INDICE	DISEGNO DRAWING DESSIN ZEICHNUNG DIBUJO	TAVOLA DRAWING TABLE BILD TABLA	INDEX NO. POS. N. INDICE	DISEGNO DRAWING DESSIN ZEICHNUNG DIBUJO	TAVOLA DRAWING TABLE BILD TABLA	INDEX NO. POS. N. INDICE
8000 90561	23	23	8000 92612	31	5	8000 96835	24	13	8000 98492	22	9	8000 99650	35	23	8000 99780	16	1
8000 91115	33	16	8000 92797	30	12	8000 96837	31	16	8000 98494	22	12	8000 99651	32	6	8000 99781	16	2
8000 91115	33A	16	8000 92797	30A	12	8000 96838	30	10	8000 98495	22	20	8000 99651	35	25	8000 99782	16	3
8000 91238	22	4	8000 92797	31	11	8000 96839	20	49	8000 98496	22	15	8000 99652	32	3	8000 99783	16	7
8000 91474	20	13	8000 93011	34	30	8000 96840	20	50	8000 98497	22	16	8000 99652	35	21	8000 99784	16	8
8000 91479	20	19	8000 93036	29	8	8000 96897	20	4	8000 98498	22	17	8000 99658	17	15	8000 99785	16	11
8000 91480	20	48	8000 93072	31	21	8000 96907	19	6	8000 98499	22	18	8000 99659	17	14	8000 99787	16	13
8000 91506	20	6	8000 93124	23	11	8000 96908	19	11	8000 98500	22	2	8000 99660	17	23	8000 99790	16	17
8000 91519	20	55	8000 93221	33A	24	8000 96923	23	1	8000 98501	22	13	8000 99661	17	27	8000 99801	3	1
8000 91525	30A	6	8000 93283	20	70	8000 96928	30	11	8000 98502	22	14	8000 99664	4	37	8000 99803	3	3
8000 91552	12	6	8000 94098	27	3	8000 96930	30	21	8000 98503	22	19	8000 99674	29	11	8000 99805	3	9
8000 91553	4	40	8000 94121	33B	4	8000 96932	30	18	8000 98504	22	6	8000 99684	4	49	8000 99826	4	1
8000 91555	8	20	8000 94125	29	3	8000 96933	30	19	8000 98520	22	6	8000 99687	4	44	8000 99833	4	15
8000 91559	16	49	8000 94126	29	4	8000 96933	30A	19	8000 98552	20	22	8000 99689	7	1	8000 99834	4	19
8000 91559	16A	49	8000 94127	29	5	8000 96934	29	17	8000 98568	22	6	8000 99690	7	5	8000 99837	4	24
8000 91564	17	3	8000 94128	29	6	8000 96938	31	12	8000 98569	22	6	8000 99694	7	8	8000 99841	3	10
8000 91565	17	8	8000 94129	29	9	8000 96938	31	12	8000 98781	20	41	8000 99698	7	14	8000 99843	8	1
8000 91566	4	24	8000 94145	33A	23	8000 96939	25	15	8000 98782	20	78	8000 99699	7	15	8000 99843	9	1
8000 91568	4	14	8000 94342	33B	28	8000 96940	31	19	8000 98783	20	79	8000 99700	7	16	8000 99846	8	2
8000 91577	4	11	8000 94595	33B	24	8000 96941	21	50	8000 98784	20	80	8000 99701	7	17	8000 99846	9	2
8000 91578	4	12	8000 94709	30A	6	8000 96944	21	18	8000 98785	20	81	8000 99702	7	10	8000 99847	8	5
8000 91579	4	13	8000 94713	31	5	8000 96997	1	19	8000 98786	20	6	8000 99703	7	12	8000 99848	9	12
8000 91580	4	15	8000 94754	30A	8	8000 97025	21	58	8000 98787	20	5	8000 99704	8	21	8000 99850	8	18
8000 91582	4	16	8000 94757	31	6	8000 97050	23	5	8000 98789	20	21	8000 99705	8	22	8000 99854	10	5
8000 91583	4	19	8000 94849	25	26	8000 97054	23	4	8000 98792	20	22	8000 99707	17	4	8000 99855	10	6
8000 91584	4	20	8000 95260	20	41	8000 97615	1	22	8000 98803	20	21	8000 99708	17	12	8000 99856	11	2
8000 91586	4	23	8000 95628	30A	11	8000 97749	20	77	8000 99299	29A	33	8000 99710	13	1	8000 99858	12	1
8000 91587	4	25	8000 95696	20	66	8000 97750	20	76	8000 99595	27	13	8000 99711	4	17	8000 99859	29	38
8000 91588	4	26	8000 95698	20	50	8000 97941	8	3	8000 99613	19	58	8000 99711	12	28	8000 99860	12	4
8000 91589	4	30	8000 95699	20	49	8000 97941	9	3	8000 99615	24	7	8000 99715	29	1	8000 99861	12	5
8000 91602	8	9	8000 95702	20	4	8000 97943	15	1	8000 99616	21	1	8000 99721	34	17	8000 99862	12	9
8000 91602	9	10	8000 95703	20	1	8000 98027	3	4	8000 99619	21	3	8000 99738	16	33	8000 99863	12	12
8000 91602	9	10	8000 95727	26	38	8000 98028	3	5	8000 99620	22	1	8000 99738	16A	33	8000 99864	12	16
8000 91610	20	21	8000 95749	1	16	8000 98116	3	6	8000 99622	33A	1	8000 99739	16	42	8000 99866	12	26
8000 91976	14	4	8000 96643	20	5	8000 98118	20	64	8000 99624	24	25	8000 99739	16A	42	8000 99868	14	8
8000 91977	14	1	8000 96645	20	22	8000 98149	16	30	8000 99625	34	17	8000 99741	16	57	8000 99869	3	1
8000 91978	14	6	8000 96647	20	41	8000 98149	16A	30	8000 99627	33A	7	8000 99741	16A	57	8000 99870	3	3
8000 91981	33	1	8000 96811	20	1	8000 98167	4	7	8000 99630	18	6	8000 99744	16	60	8000 99871	3	4
8000 91983	35	32	8000 96813	20	4	8000 98209	24	6	8000 99631	27	1	8000 99744	16A	60	8000 99876	7	1
8000 91984	14	3	8000 96830	29	2	8000 98237	20	58	8000 99632	30	16	8000 99747	3	6	8000 99877	7	5
8000 92414	31	9	8000 96831	29	1	8000 98489	22	5	8000 99648	28	7	8000 99775	32	1	8000 99880	7	8
8000 92433	4	10	8000 96833	24	9	8000 98490	22	7	8000 99650	32	2	8000 99775	35	20	8000 99887	4	37



DISEGNO DRAWING DESSIN ZEICHNUNG DIBUJO	TAVOLA DRAWING TABLE BILD TABLA	INDEX NO. POS. N. INDICE	DISEGNO DRAWING DESSIN ZEICHNUNG DIBUJO	TAVOLA DRAWING TABLE BILD TABLA	INDEX NO. POS. N. INDICE	DISEGNO DRAWING DESSIN ZEICHNUNG DIBUJO	TAVOLA DRAWING TABLE BILD TABLA	INDEX NO. POS. N. INDICE	DISEGNO DRAWING DESSIN ZEICHNUNG DIBUJO	TAVOLA DRAWING TABLE BILD TABLA	INDEX NO. POS. N. INDICE	DISEGNO DRAWING DESSIN ZEICHNUNG DIBUJO	TAVOLA DRAWING TABLE BILD TABLA	INDEX NO. POS. N. INDICE	DISEGNO DRAWING DESSIN ZEICHNUNG DIBUJO	TAVOLA DRAWING TABLE BILD TABLA	INDEX NO. POS. N. INDICE
8000 99888	13	1	8000 A0071	33	9	8000 A0408	28	7	8000 A0678	34	2	8000 A0879	29A	5	8000 A1052	35	8
8000 99913	5	6	8000 A0071	33A	9	8000 A0408	28	7	8000 A0680	27	19	8000 A0882	6	12	8000 A1053	33B	16
8000 99915	5	5	8000 A0080	30	8	8000 A0414	28	10	8000 A0681	18	6	8000 A0882	6	12	8000 A1053	35	9
8000 99916	5	7	8000 A0081	30	9	8000 A0416	28	7	8000 A0692	31	14	8000 A0883	32	5	8000 A1137	29	39
8000 99919	16	27	8000 A0085	31	6	8000 A0528	27	9	8000 A0693	31	29	8000 A0883	35	24	8000 A1189	29A	11
8000 99922	3	14	8000 A0086	31	7	8000 A0545	26	12	8000 A0694	29A	1	8000 A0891	28	3	8000 A1216	15	10
8000 99923	3	15	8000 A0091	16	31	8000 A0545	26	12	8000 A0702	27	8	8000 A0892	28	4	8000 A1220	33A	20
8000 99928	24	32	8000 A0092	16	32	8000 A0546	26	12	8000 A0709	15	4	8000 A0893	28	6	8000 A1279	15	31
8000 99930	6	17	8000 A0107	33	13	8000 A0567	4	5	8000 A0710	15	5	8000 A0900	18	14	8000 A1280	33	8
8000 99933	6	21	8000 A0107	33A	13	8000 A0568	4	13	8000 A0724	39	5	8000 A0902	18	15	8000 A1280	33A	8
8000 99938	5	1	8000 A0110	33	14	8000 A0571	14	1	8000 A0725	39	4	8000 A0911	24	11	8000 A1299	16A	1
8000 99939	5	2	8000 A0110	33A	14	8000 A0572	14	2	8000 A0730	6	7	8000 A0912	24	5	8000 A1300	16A	2
8000 99949	28	7	8000 A0111	33	15	8000 A0573	14	12	8000 A0731	33	28	8000 A0913	24	15	8000 A1301	16A	12
8000 99953	6	10	8000 A0111	33A	15	8000 A0574	4	34	8000 A0731	33A	21	8000 A0914	24	30	8000 A1302	16A	13
8000 99953	6	10	8000 A0227	34	6	8000 A0575	4	35	8000 A0732	33	29	8000 A0915	24	22	8000 A1313	3	16
8000 99956	15	27	8000 A0228	34	11	8000 A0579	16	52	8000 A0732	33A	22	8000 A0916	13	2	8000 A1315	3	14
8000 99957	15	30	8000 A0229	34	25	8000 A0579	16A	52	8000 A0739	15	27	8000 A0917	13	2	8000 A1316	16A	27
8000 99958	15	3	8000 A0230	34	26	8000 A0597	19	2	8000 A0746	15	12	8000 A0918	13	2	8000 A1322	16	1
8000 99959	15	6	8000 A0232	4	33	8000 A0600	29	8	8000 A0749	6	17	8000 A0927	29	9	8000 A1323	16	2
8000 99960	15	7	8000 A0233	33B	17	8000 A0604	3	3	8000 A0751	6	18	8000 A0928	29	39	8000 A1324	16	3
8000 99962	15	51	8000 A0233	33B	17	8000 A0606	3	4	8000 A0765	10	2	8000 A0929	29	15	8000 A1325	16	7
8000 99964	15	35	8000 A0233	35	10	8000 A0607	3	6	8000 A0779	17	28	8000 A0930	29	25	8000 A1326	16	8
8000 99965	15	37	8000 A0233	35	10	8000 A0611	6	5	8000 A0811	29A	6	8000 A0931	25	19	8000 A1327	16	11
8000 99966	15	40	8000 A0241	26	28	8000 A0633	20	51	8000 A0843	32	1	8000 A0931	29	19	8000 A1328	16	63
8000 99971	15	42	8000 A0264	19	52	8000 A0633	20	51	8000 A0852	3	3	8000 A0932	29	18	8000 A1329	16	12
8000 99972	15	43	8000 A0266	19	53	8000 A0638	39	2	8000 A0854	3	4	8000 A0933	25	17	8000 A1330	16	13
8000 99973	15	49	8000 A0267	19	56	8000 A0645	34	1	8000 A0855	3	6	8000 A0934	25	34	8000 A1332	16	15
8000 99983	5	1	8000 A0268	19	54	8000 A0656	18	4	8000 A0864	33B	18	8000 A0939	24	18	8000 A1333	16	17
8000 99984	5	2	8000 A0269	19	55	8000 A0663	8	28	8000 A0864	35	11	8000 A0953	33B	8	8000 A1334	16	18
8000 A0001	3	1	8000 A0278	33B	9	8000 A0664	32	4	8000 A0865	2	6	8000 A0989	4	29	8000 A1335	16	19
8000 A0005	3	14	8000 A0278	35	2	8000 A0664	35	22	8000 A0865	19	7	8000 A0992	33	26	8000 A1336	16	20
8000 A0006	3	3	8000 A0303	4	48	8000 A0665	25	23	8000 A0866	28	1	8000 A0993	33	7	8000 A1353	28	19
8000 A0008	3	4	8000 A0308	22	1	8000 A0667	27	25	8000 A0867	28	2	8000 A0994	33	14	8000 A1427	2	2
8000 A0009	3	6	8000 A0339	27	5	8000 A0668	27	24	8000 A0868	28	3	8000 A0995	33	15	8000 A1427	19	60
8000 A0031	4	37	8000 A0341	4	9	8000 A0669	17	24	8000 A0869	28	4	8000 A1011	15	8	8000 A1430	14	1
8000 A0032	13	1	8000 A0342	4	9	8000 A0670	17	25	8000 A0870	28	5	8000 A1017	15	33	8000 A1431	14	6
8000 A0033	14	11	8000 A0369	28	7	8000 A0671	17	26	8000 A0871	28	6	8000 A1022	15	9	8000 A1433	33	1
8000 A0045	3	16	8000 A0375	22	1	8000 A0672	29A	19	8000 A0872	17	34	8000 A1041	4	5	8000 A1503	22	2
8000 A0050	26	1	8000 A0393	29A	20	8000 A0675	19	46	8000 A0873	28	20	8000 A1048	34	32	8000 A1504	22	3
8000 A0051	26	24	8000 A0395	28	7	8000 A0676	19	44	8000 A0874	28	8	8000 A1051	33B	14	8000 A1505	22	3
8000 A0051	26	24	8000 A0395	28	7	8000 A0677	2	7	8000 A0877	24	16	8000 A1051	35	7	8000 A1506	22	3
8000 A0055	24	12	8000 A0396	35	1	8000 A0677	19	37	8000 A0878	24	10	8000 A1052	33B	15	8000 A1507	22	5

DISEGNO DRAWING DESSIN ZEICHNUNG DIBUJO	TAVOLA DRAWING TABLE BILD TABLA	INDEX NO. POS. N. INDICE	DISEGNO DRAWING DESSIN ZEICHNUNG DIBUJO	TAVOLA DRAWING TABLE BILD TABLA	INDEX NO. POS. N. INDICE	DISEGNO DRAWING DESSIN ZEICHNUNG DIBUJO	TAVOLA DRAWING TABLE BILD TABLA	INDEX NO. POS. N. INDICE	DISEGNO DRAWING DESSIN ZEICHNUNG DIBUJO	TAVOLA DRAWING TABLE BILD TABLA	INDEX NO. POS. N. INDICE	DISEGNO DRAWING DESSIN ZEICHNUNG DIBUJO	TAVOLA DRAWING TABLE BILD TABLA	INDEX NO. POS. N. INDICE	DISEGNO DRAWING DESSIN ZEICHNUNG DIBUJO	TAVOLA DRAWING TABLE BILD TABLA	INDEX NO. POS. N. INDICE
8000 A1508	22	8	8000 A1824	13	5	8000 A2782	37	4	8000 A3091	13	5	8000 A3653	22	3	80G0 69338	20	67
8000 A1509	22	10	8000 A1882	2	10	8000 A2782	38	5	8000 A3113	36	11	8000 A3713	39	8	8A00 01815	19	13
8000 A1510	22	13	8000 A1882	33A	19	8000 A2783	36	5	8000 A3113	37	9	8000 A3714	39	9	8A00 06911	33	11
8000 A1512	1	4	8000 A1891	33	7	8000 A2783	37	5	8000 A3113	38	9	8000 A3787	7	5	8A00 06911	33A	11
8000 A1559	1	3	8000 A1891	33A	7	8000 A2783	38	4	8000 A3114	36	10	8000 A3975	25	24	8A00 15960	3	8
8000 A1576	1	6	8000 A1913	16	15	8000 A2787	25	15	8000 A3114	37	10	8000 A4287	15	18	8A00 15960	10	11
8000 A1579	1	9	8000 A1914	16	18	8000 A2790	25	16	8000 A3114	38	8	8000 A4337	15	20	8A00 18246	33B	3
8000 A1580	1	2	8000 A1915	16	19	8000 A2791	25	17	8000 A3122	35	1	8000 A4571	15	44	8A00 19768	8	8
8000 A1625	1	8	8000 A1916	16	20	8000 A2792	25	30	8000 A3191	2	11	80A0 42349	27	16	8A00 19768	9	9
8000 A1626	39	7	8000 A1918	16A	15	8000 A2793	25	31	8000 A3191	20	7	80A0 52662	29A	2	8A00 20373	33B	7
8000 A1627	39	6	8000 A1919	16A	66	8000 A2794	25	32	8000 A3195	36	2	80A0 69551	22	22	8A00 26846	31	20
8000 A1706	29A	20	8000 A1920	16A	19	8000 A2816	22	1	8000 A3195	37	2	80A0 73456	21	15	8A00 28183	5	9
8000 A1707	29A	25	8000 A1921	16A	20	8000 A2817	21	1	8000 A3195	38	2	80A0 74388	21	22	8A00 28553	10	17
8000 A1708	29A	23	8000 A1926	16	12	8000 A2819	22	1	8000 A3196	36	3	80A0 87800	26	29	8A00 28855	10	3
8000 A1709	30A	16	8000 A1928	16A	12	8000 A2836	24	4	8000 A3196	37	3	80A0 89953	19	9	8A00 37283	33B	19
8000 A1748	16	45	8000 A1942	4	8	8000 A2837	24	11	8000 A3196	38	3	80A0 89962	19	10	8A00 37283	35	12
8000 A1748	16A	45	8000 A1948	14	2	8000 A2840	24	5	8000 A3197	37	13	80A0 91548	4	22	8A00 37947	18	11
8000 A1761	2	8	8000 A2040	29A	26	8000 A2841	24	7	8000 A3197	38	13	80A0 91551	10	16	8A00 38350	6	2
8000 A1761	26	3	8000 A2041	29A	27	8000 A2842	36	8	8000 A3198	37	12	80A0 91792	18	1	8A00 41459	33	10
8000 A1794	13	10	8000 A2042	29A	28	8000 A2842	37	8	8000 A3198	38	12	80A0 95696	20	66	8A00 41459	33A	10
8000 A1795	13	12	8000 A2043	29A	29	8000 A2843	24	25	8000 A3201	39	3	80A0 97857	39	3	8A00 42100	9	6
8000 A1796	13	11	8000 A2044	34	33	8000 A2851	36	8	8000 A3327	38	11	80A0 99172	10	1	8A00 42700	16	53
8000 A1797	13	13	8000 A2121	4	37	8000 A2851	37	8	8000 A3327	39	11	80A0 99173	10	13	8A00 42700	16A	53
8000 A1798	13	19	8000 A2122	36	9	8000 A2857	3	16	8000 A3378	3	5	80A0 99174	11	1	8A00 47773	5	8
8000 A1799	13	20	8000 A2122	37	11	8000 A2861	37	8	8000 A3408	24	14	80A0 99774	32	9	8A00 47773	12	3
8000 A1800	13	17	8000 A2122	38	10	8000 A2863	4	1	8000 A3409	24	23	80A0 99774	35	28	8A00 48127	16A	32
8000 A1801	13	16	8000 A2122	39	10	8000 A2866	3	16	8000 A3410	24	20	80A0 99836	4	22	8A00 53504	30	6
8000 A1802	13	21	8000 A2141	4	36	8000 A2870	37	8	8000 A3455	5	1	80A0 A0233	33B	17	8A00 55241	8	4
8000 A1803	13	18	8000 A2242	7	14	8000 A2924	1	17	8000 A3458	6	17	80A0 A0233	35	10	8A00 55241	8	4
8000 A1804	13	7	8000 A2352	21	62	8000 A2925	1	18	8000 A3463	5	1	80A0 A0633	20	51	8A00 55241	8	29
8000 A1804	13	7	8000 A2654	6	10	8000 A2926	1	20	8000 A3466	6	17	80A0 A0942	10	13	8A00 55241	9	4
8000 A1806	13	8	8000 A2714	3	5	8000 A2932	3	14	8000 A3485	16	58	80A0 A1054	11	1	8A00 55241	9	4
8000 A1808	13	15	8000 A2731	4	8	8000 A2959	8	1	8000 A3485	16A	58	80A0 A1589	2	8	8A00 55241	25	11
8000 A1809	13	9	8000 A2765	7	5	8000 A2959	9	1	8000 A3488	16	57	80A0 A1761	26	3	8A00 55241	30	17
8000 A1809	13	9	8000 A2771	3	14	8000 A2980	3	1	8000 A3488	16A	57	80A0 A3197	39	13	8A00 55860	31	5
8000 A1809	13	9	8000 A2777	36	7	8000 A3016	2	4	8000 A3644	22	2	80A0 A3198	39	12	8A00 58929	31	5
8000 A1810	13	16	8000 A2777	37	7	8000 A3016	15	34	8000 A3645	22	3	80B0 73832	20	82	8A00 58930	31	5
8000 A1822	2	3	8000 A2777	38	7	8000 A3017	15	39	8000 A3647	22	10	80B0 73832	20	82	8A00 59433	19	38
8000 A1822	13	5	8000 A2778	36	6	8000 A3084	13	1	8000 A3648	22	12	80B0 87800	26	29	8A00 59434	19	40
8000 A1823	2	3	8000 A2778	37	6	8000 A3087	3	16	8000 A3649	22	13	80C0 69338	20	67	8A00 60415	17	1
8000 A1823	13	5	8000 A2778	38	6	8000 A3088	38	11	8000 A3650	22	14	80G0 69337	20	66	8A00 61261	16A	9
8000 A1824	2	3	8000 A2782	36	4	8000 A3091	2	3	8000 A3651	22	20	80G0 69338	20	67	8A00 62714	29A	10

DISEGNO DRAWING DESSIN ZEICHNUNG DIBUJO	TAVOLA DRAWING TABLE BILD TABLA	INDEX NO. POS. N. INDICE	DISEGNO DRAWING DESSIN ZEICHNUNG DIBUJO	TAVOLA DRAWING TABLE BILD TABLA	INDEX NO. POS. N. INDICE	DISEGNO DRAWING DESSIN ZEICHNUNG DIBUJO	TAVOLA DRAWING TABLE BILD TABLA	INDEX NO. POS. N. INDICE	DISEGNO DRAWING DESSIN ZEICHNUNG DIBUJO	TAVOLA DRAWING TABLE BILD TABLA	INDEX NO. POS. N. INDICE	DISEGNO DRAWING DESSIN ZEICHNUNG DIBUJO	TAVOLA DRAWING TABLE BILD TABLA	INDEX NO. POS. N. INDICE	DISEGNO DRAWING DESSIN ZEICHNUNG DIBUJO	TAVOLA DRAWING TABLE BILD TABLA	INDEX NO. POS. N. INDICE
8A00 62797	22	30	8A00 96930	30A	21	8A00 A1804	13	7	8B00 79785	31	27	8CA0 A0545	26	12	8G00 96837	31	16
8A00 65503	20	56	8A00 96932	30A	18	8A00 A1806	13	8	8B00 80171	13	6	8CA0 A0546	26	12	8G00 99475	4	50
8A00 65847	8	12	8A00 96937	31	8	8A00 A1806	13	8	8B00 81650	8	25	8D00 01261	12	18	8G00 99587	19	1
8A00 66661	21	34	8A00 96938	31	12	8A00 A1806	13	8	8B00 81650	9	17	8D00 26846	31	10	8G00 99840	3	9
8A00 67016	15	36	8A00 97015	20	49	8A00 A1806	13	8	8B00 82879	30A	3	8D00 28183	5	9	8G00 A1804	13	7
8A00 67207	19	61	8A00 97016	20	50	8A00 A1807	13	14	8B00 82879	31	3	8D00 36022	15	14	8G00 A1804	13	7
8A00 67545	10	8	8A00 97054	23	4	8A00 A1809	13	9	8B00 91582	4	16	8D00 36022	16	5	8G00 A2141	4	36
8A00 67545	11	3	8A00 97593	31	8	8A00 A1809	13	9	8B00 94010	27	20	8D00 36022	16A	5	8H00 28183	5	9
8A00 67997	14	9	8A00 97739	16	28	8A00 A1809	13	9	8B00 96837	31	16	8D00 43716	17	18	8H00 80171	13	6
8A00 67997	20	52	8A00 97739	16A	28	8A00 A1809	13	9	8B00 96838	30A	10	8D00 62797	23	17	8H00 80171	13	6
8A00 67997	21	23	8A00 98534	2	8	8A00 A2044	34	34	8B00 99475	17	13	8D00 67545	27	7	8H00 95276	18	16
8A00 69282	21	26	8A00 98534	26	3	8A00 A2141	4	36	8B00 99475	17	30	8D00 80171	13	6	8H00 99840	3	9
8A00 69315	20	57	8A00 98574	6	18	8A00 A2836	24	4	8B00 99805	3	9	8D00 96746	6	1	8H00 A1804	13	7
8A00 71091	19	22	8A00 99475	17	29	8A00 A3485	16	58	8B00 99840	3	9	8D00 96837	31	16	8H00 A1804	13	7
8A00 74716	12	27	8A00 99587	19	1	8A00 A3485	16A	58	8B00 A0050	26	1	8D00 99840	3	9	8H00 A1804	13	7
8A00 76026	25	9	8A00 99660	17	23	8AA0 73909	21	16	8B00 A0226	2	9	8D00 A2141	4	36	8H00 A1804	13	7
8A00 80171	13	6	8A00 99666	24	4	8AA0 88866	26	9	8B00 A1804	13	7	8E00 18282	15	38	8H00 A2141	4	36
8A00 84473	15	29	8A00 99805	3	9	8AA0 88867	26	10	8B00 A1806	13	8	8E00 30053	6	20	8J00 A1804	13	7
8A00 85071	4	3	8A00 99805	3	9	8AA0 88868	27	23	8B00 A1806	13	8	8E00 32069	16A	23	8J00 A1804	13	7
8A00 86136	23	8	8A00 99840	3	9	8AA0 88869	27	22	8B00 A1806	13	8	8E00 34292	12	14	8J00 A2141	4	36
8A00 86138	23	6	8A00 99913	5	6	8AB0 88866	26	9	8B00 A1806	13	8	8E00 79783	31	27	8K00 A1804	13	7
8A00 86938	31	9	8A00 99953	6	10	8AB0 88866	26	9	8B00 A1809	13	9	8E00 80171	13	6	8K00 A1804	13	7
8A00 86980	16A	31	8A00 A0050	26	1	8AB0 88867	26	10	8B00 A2141	4	36	8E00 80171	13	6	8K00 A1804	13	7
8A00 87289	15	4	8A00 A0051	26	24	8AB0 88867	26	10	8C00 26846	31	20	8E00 99475	18	12	8K00 A2141	4	36
8A00 87717	20	3	8A00 A0085	31	6	8AB0 88868	27	23	8C00 28183	5	9	8E00 99587	19	1	8L00 66179	25	20
8A00 87810	21	10	8A00 A0129	14	13	8AB0 88868	27	23	8C00 35794	7	4	8E00 99840	3	9	8L00 A2141	4	36
8A00 88873	33B	1	8A00 A0232	4	33	8AB0 88869	27	22	8C00 48590	15	16	8E00 A2141	4	36	8M00 A2141	4	36
8A00 90622	1	5	8A00 A0264	19	52	8AB0 88869	27	22	8C00 56768	31	27	8F00 28183	5	9	8N00 99587	19	1
8A00 91582	4	16	8A00 A0303	4	48	8B00 07989	15	41	8C00 61121	21	20	8F00 35794	7	4	8N00 A2141	4	36
8A00 91975	14	2	8A00 A0611	6	5	8B00 26846	31	10	8C00 62797	29A	24	8F00 67545	10	9	8P00 A2141	4	36
8A00 92876	30A	17	8A00 A0665	25	23	8B00 36023	16A	10	8C00 63811	7	3	8F00 79785	31	27	8R00 A2141	4	36
8A00 92986	30	15	8A00 A0702	27	8	8B00 43715	17	16	8C00 67997	26	25	8F00 80171	13	6	8S00 67545	3	7
8A00 92986	30A	15	8A00 A0866	28	1	8B00 55241	9	7	8C00 68934	24	21	8F00 A2141	4	36	8S00 67545	10	10
8A00 93011	34	31	8A00 A0867	28	2	8B00 65442	31	27	8C00 69056	20	65	8G00 07989	16	22	8S00 68873	27	12
8A00 93124	23	13	8A00 A0868	28	3	8B00 65503	15	15	8C00 80171	13	6	8G00 07989	16	23	8S00 80171	13	6
8A00 94119	33B	2	8A00 A0869	28	4	8B00 66525	20	71	8C00 80171	13	6	8G00 07989	16A	22	8S00 A2141	4	36
8A00 94120	33B	6	8A00 A0873	28	20	8B00 66953	9	14	8C00 81650	8	25	8G00 66179	29A	13	8SA0 67545	33	17
8A00 95698	20	50	8A00 A0882	6	12	8B00 67545	27	7	8C00 81650	9	17	8G00 70379	28	9	8SA0 67545	33A	17
8A00 95699	20	49	8A00 A0891	28	3	8B00 68934	24	21	8C00 96746	6	1	8G00 73458	19	27	8T00 80171	13	6
8A00 96643	20	5	8A00 A0892	28	4	8B00 69056	19	65	8C00 96837	31	16	8G00 73458	19	28	8T00 80171	13	6
8A00 96811	20	1	8A00 A0939	24	18	8B00 69282	26	26	8C00 99587	19	1	8G00 80171	13	6	8T00 A2141	4	36
8A00 96837	31	16	8A00 A1800	13	22	8B00 79783	31	27	8C00 A2141	4	36	8G00 80171	13	6	8U00 80171	13	6

DISEGNO DRAWING DESSIN ZEICHNUNG DIBUJO	TAVOLA DRAWING TABLE BILD TABLA	INDEX NO. POS. N. INDICE	DISEGNO DRAWING DESSIN ZEICHNUNG DIBUJO	TAVOLA DRAWING TABLE BILD TABLA	INDEX NO. POS. N. INDICE	DISEGNO DRAWING DESSIN ZEICHNUNG DIBUJO	TAVOLA DRAWING TABLE BILD TABLA	INDEX NO. POS. N. INDICE	DISEGNO DRAWING DESSIN ZEICHNUNG DIBUJO	TAVOLA DRAWING TABLE BILD TABLA	INDEX NO. POS. N. INDICE	DISEGNO DRAWING DESSIN ZEICHNUNG DIBUJO	TAVOLA DRAWING TABLE BILD TABLA	INDEX NO. POS. N. INDICE
8U00 A2141	..... 4	..... 36												
8V00 80171	..... 13	..... 6												
8V00 A2141	..... 4	..... 36												
8W00 68873	..... 27	..... 2												
8W00 80171	..... 13	..... 6												
8W00 A2141	..... 4	..... 36												

**CATALOGO PARTI DI RICAMBIO - PARTS CATALOG  
CATALOGUE PIECES DE RECHANGE - ERSATZTEILKATALOG  
CATALOGO PIEZAS DE REPUESTO**

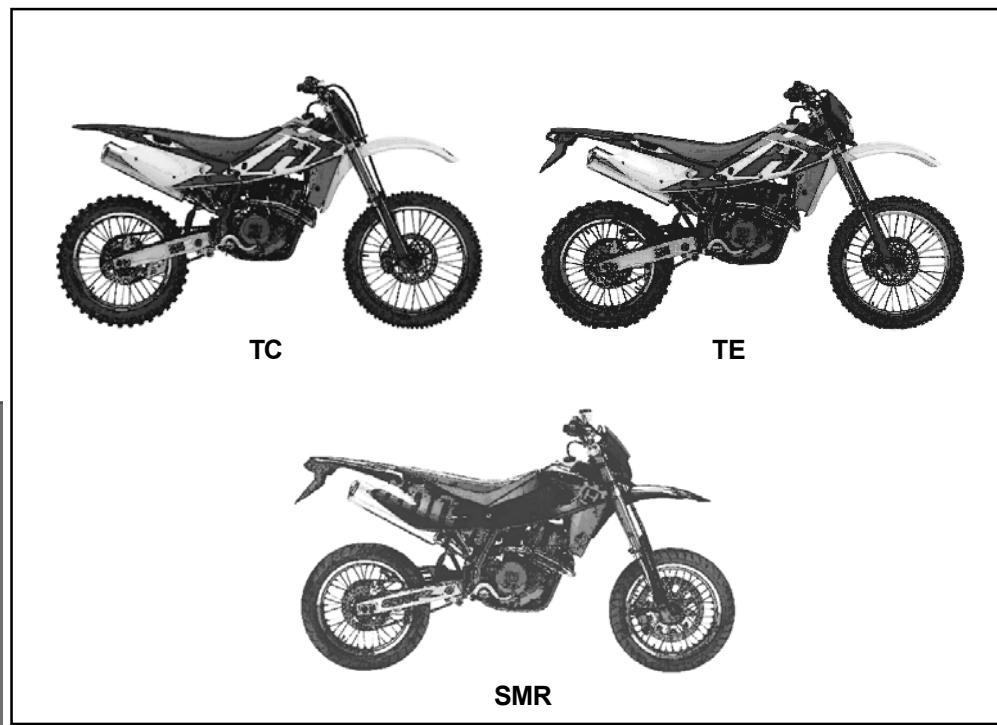

Part. N° 8000 A2926  
Ed. 04-2004

***TC-TE 250-450,  
SM 400R-450R / 2004***